

SV 415 E
SC 1.5 E

STIGA[®]

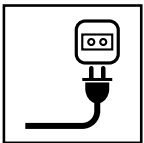

- IT** Scarificatori e aeratori elettrici alimentati dalla rete con operatore a terra
MANUALE DI ISTRUZIONI
ATTENZIONE: prima di usare la macchina, leggere attentamente il presente libretto.
- BG** Електрически скарификатори и аератори захранвани от мрежата,
управлявани от съпровождащ оператор
УПЪТВАНЕ ЗА УПОТРЕБА
ВНИМАНИЕ: преди да използвате машината прочетете внимателно настоящата книжка.
- BS** Električni prozračivači i aeratori travnjaka na guranje s mrežnim napajanjem
UPUTSTVO ZA UPOTREBU
PAŽNJA: prije nego što koristite ovu mašinu, pažljivo pročitajte priručnik s uputama.
- CS** Prořezávače a provzdušňovače napájené z elektrické sítě, s obsluhou na zemi
NÁVOD K POUŽITÍ
UPOZORNĚNÍ: před použitím stroje si pozorně přečtěte tento návod k použití.
- DA** Netdrevne græskultivatorer og plæneluftere betjent af gående personer
BRUGSANVISNING
ADVARSEL: læs instruktionsbogen omhyggeligt igennem, før du tager denne maskine i brug.
- DE** Elektrische, am Stromnetz versorgte Vertikutierer und Bodenbelüfter mit Bediener am Boden
GEBRAUCHSANWEISUNG
ACHTUNG: vor Inbetriebnahme des Geräts die Gebrauchsanleitung aufmerksam lesen.
- EL** Ηλεκτρικοί εξαερωτές και αποβρωωτές πεζού χειριστή
ΟΔΗΓΙΕΣ ΧΡΗΣΗΣ
ΠΡΟΣΟΧΗ: πριν χρησιμοποιήσετε το μηχάνημα, διαβάστε προσεκτικά το παρόν εγχειρίδιο.
- EN** Pedestrian-controlled mains-operated lawn scarifiers and aerators
OPERATOR'S MANUAL
WARNING: read thoroughly the instruction booklet before using the machine.
- ES** Escarificadores y aireadores eléctricos alimentados por la red con operador en el suelo
MANUAL DE INSTRUCCIONES
ATENCIÓN: antes de utilizar la máquina, leer atentamente el presente manual.
- ET** Jalgsijuhitavad võrgutoitega murukobestid ja -aeraatorid
KASUTUSJUHEND
TÄHELEPANU: enne masina kasutamist lugeda tähelepanelikult antud kasutusjuhendit.
- FI** Kävellin ohjattavat verkkokäyttöiset nurmikoon rei'ityskoneet ja ilmastimet
KÄYTTÖOHJEET
VAROITUS: lue käyttöopas huolellisesti ennen koneen käyttöä.
- FR** Scarificateurs de gazon et aérateurs fonctionnant sur le réseau et pour conducteur à pied
MANUEL D'UTILISATION
ATTENTION: lire attentivement le manuel avant d'utiliser cette machine.
- HR** Električni ručno vođeni prozračivači za travnjake s mrežnim napajanjem
PRIRUČNIK ZA UPORABU
POZOR: prije uporabe stroja, pažljivo pročitajte ovaj priručnik.
- HU** Gyalogvezetésű elektromos fűnyírógép
HASZNÁLATI UTASÍTÁS
FIGYELEM! a gép használatá előtt olvassa el figyelmesen a jelen kézikönyvet.
- LT** Pėsčiojo valdomi iš tinklo maitinami aeratoriai ir vejų purentuvai
NAUDOJIMO INSTRUKCIJOS
DĖMESIO: prieš naudojant įrenginį, atidžiai perskaityti šį naudotojo vadovą.
- LV** Kājniekvadāmi no elektrotīkla darbināmi zāliena skarifikatori un aeratori
LIETOŠANAS INSTRUKCIJA
UZMANĪBU: pirms aparāta lietošanai rūpīgi izlasiet doto instrukciju.
- MK** Електрични раздувачи и прибирачи со напојување на струја и со управувач на земја
УПАТСТВА ЗА УПОТРЕБА
ВНИМАНИЕ: прочитајте го внимателно ова упатство пред да ја користите машината.

- NL** Elektrische via het net aangedreven grasmattbeluchters en verticuteermachines met meelopende bestuurder
GEBRUIKERSHANDLEIDING
LET OP: vooraleer de machine te gebruiken, dient men deze handleiding aandachtig te lezen.
- NO** Nettstrømdrevne plenluftere og kultivatorer med operatør på bakken
INSTRUKSJONSBOK
ADVARSEL: les denne bruksanvisningen nøye før du bruker maskinen.
- PL** Spulchniarki i aeratory elektryczne, zasilane z sieci, obsługiwane przez operatora pieszezo
INSTRUKCJE OBSŁUGI
OSTRZEŻENIE: przed użyciem maszyny, należy uważnie przeczytać niniejszą instrukcję.
- PT** Escarificadores e arejadores elétricos alimentados pela rede com operador no chão
MANUAL DE INSTRUÇÕES
ATENÇÃO: antes de usar a máquina, leia atentamente o presente manual.
- RO** Scarificatoare și prășitoare electrice alimentate de la rețea, cu conducător pedestru
MANUAL DE INSTRUCȚIUNI
ATENȚIE: înainte de a utiliza mașina, citiți cu atenție manualul de față.
- RU** Скарификаторы и аэраторы, работающие от электрической сети питания и управляемые идущим рядом оператором
РУКОВОДСТВО ПО ЭКСПЛУАТАЦИИ
ВНИМАНИЕ: прежде чем пользоваться оборудованием, внимательно прочтите это руководство по эксплуатации.
- SK** Prerezávače a prevzdušňovače napájané z elektrickej siete, s obsluhou na zemi
NÁVOD NA POUŽITIE
UPOZORNENIE: pred použitím stroja si pozorne prečítajte tento návod.
- SL** Ročno upravljani rahljalniki in prezračevalniki travne ruše, priključeni na omrežje
PRIROČNIK ZA UPORABO
POZOR: preden uporabite stroj, pazljivo preberite priročnik z navodili.
- SR** Električni prozračivači i aeratori travnjaka na guranje s mrežnim napajanjem
PRIRUČNIK SA UPUTSTVIMA
PAŽNJA: pre korišćenja mašine pažljivo pročitati ovaj priručnik.
- SV** Förladda elektriska nätdrivna gräsflutare och kultivatorer
BRUKSANVISNING
VARNING: läs igenom hela detta häfte innan du använder maskinen.
- TR** Yerde operatör ile şebeke beslemeli elektrikli çim kazıyıcı ve havalandırıcılar
KULLANIM KILAVUZU
DİKKAT: makineyi kullanmadan önce talimatlar içeren kılavuzu dikkatle okuyun.

ITALIANO - Istruzioni Originali	IT
БЪЛГАРСКИ - Превод на оригиналните инструкции	BG
BOSANSKI - Prijevod originalnih uputa	BS
ČESKY - Překlad původního návodu k používání	CS
DANSK - Oversættelse af den originale brugsanvisning	DA
DEUTSCH - Originalbetriebsanleitung	DE
ΕΛΛΗΝΙΚΑ - Μετάφραση του πρωτοτύπου των οδηγιών χρήσης	EL
ENGLISH - Translation of the original instruction	EN
ESPAÑOL - Traducción del Manual Original	ES
EESTI - Algupärased kasutusjuhendi tõlge	ET
SUOMI - Alkuperäisten ohjeiden käännös	FI
FRANÇAIS - Traduction de la notice originale	FR
HRVATSKI - Prijevod originalnih uputa	HR
MAGYAR - Eredeti használati utasítás fordítása	HU
LIETUVIŠKAI - Originalių instrukcijų vertimas	LT
LATVIEŠU - Instrukciju tulkojums no oriģinālvalodas	LV
МАКЕДОНСКИ - Превод на оригиналните упатства	MK
NEDERLANDS - Vertaling van de oorspronkelijke gebruiksaanwijzing	NL
NORSK - Oversettelse av original bruksanvisning	NO
POLSKI - Tłumaczenie instrukcji oryginalnej	PL
PORTUGUÊS - Tradução do manual original	PT
ROMÂN - Traducerea manualului fabricantului	RO
РУССКИЙ - Перевод оригинальных инструкций	RU
SLOVENSKY - Preklad pôvodného návodu na použitie	SK
SLOVENŠČINA - Prevod izvirnih navodil	SL
SRPSKI - Prevod originalnih uputstva	SR
SVENSKA - Översättning av bruksanvisning i original	SV
TÜRKÇE - Orijinal Talimatların Tercümesi	TR

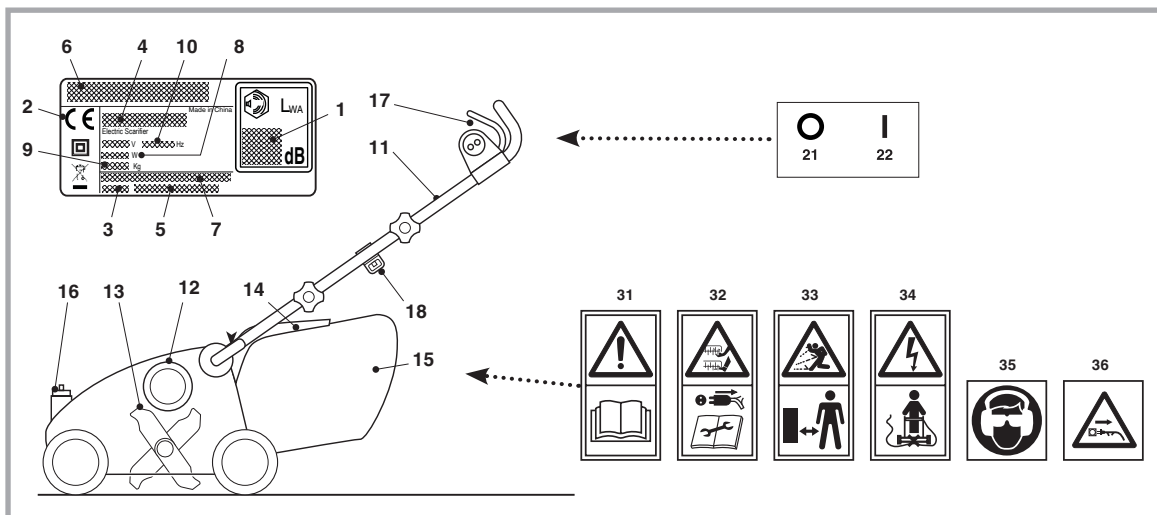

		SV 415 E SC 1.5 E
[61]	kW	1500
[62]	min ⁻¹	4000
[63]	kg	14,5
[64]	cm	38
[65]	dB(A)	81
[66]	dB(A)	3
[67]	dB(A)	90
[66]	dB(A)	3
[68]	dB(A)	94
[69]	m/s ²	3,05
[66]	m/s ²	1,5
[70]	STIGA SpA	118802686/0
	KINGCLEAN	J2420000171R
[71]	STIGA SpA	118802312/0

1.1

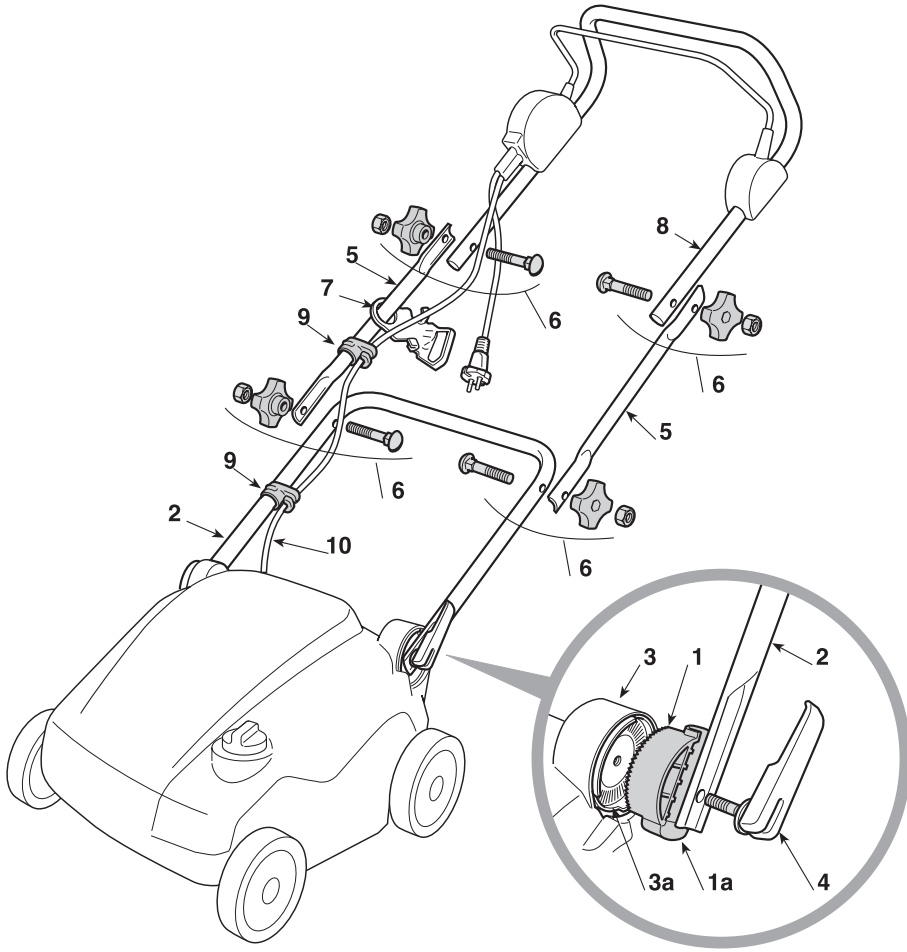

1.2

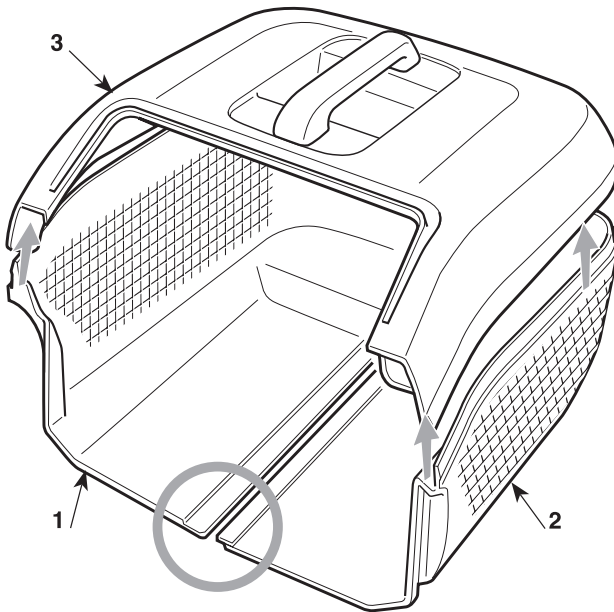

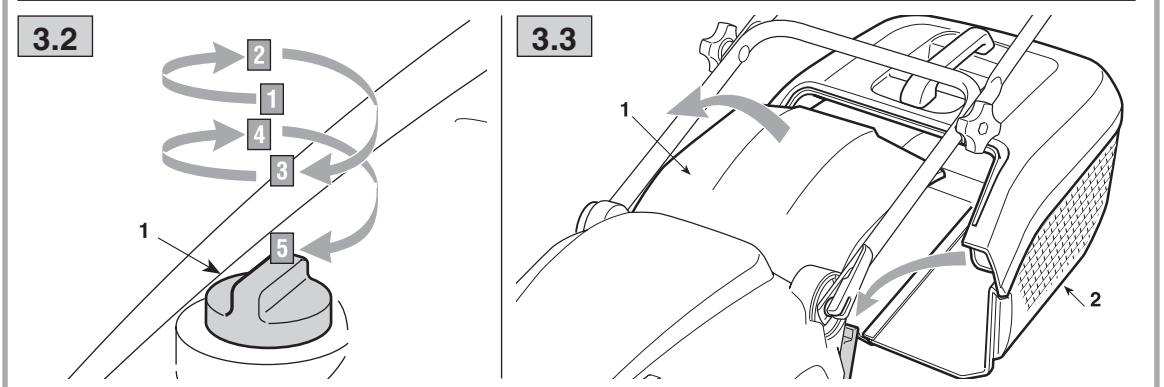
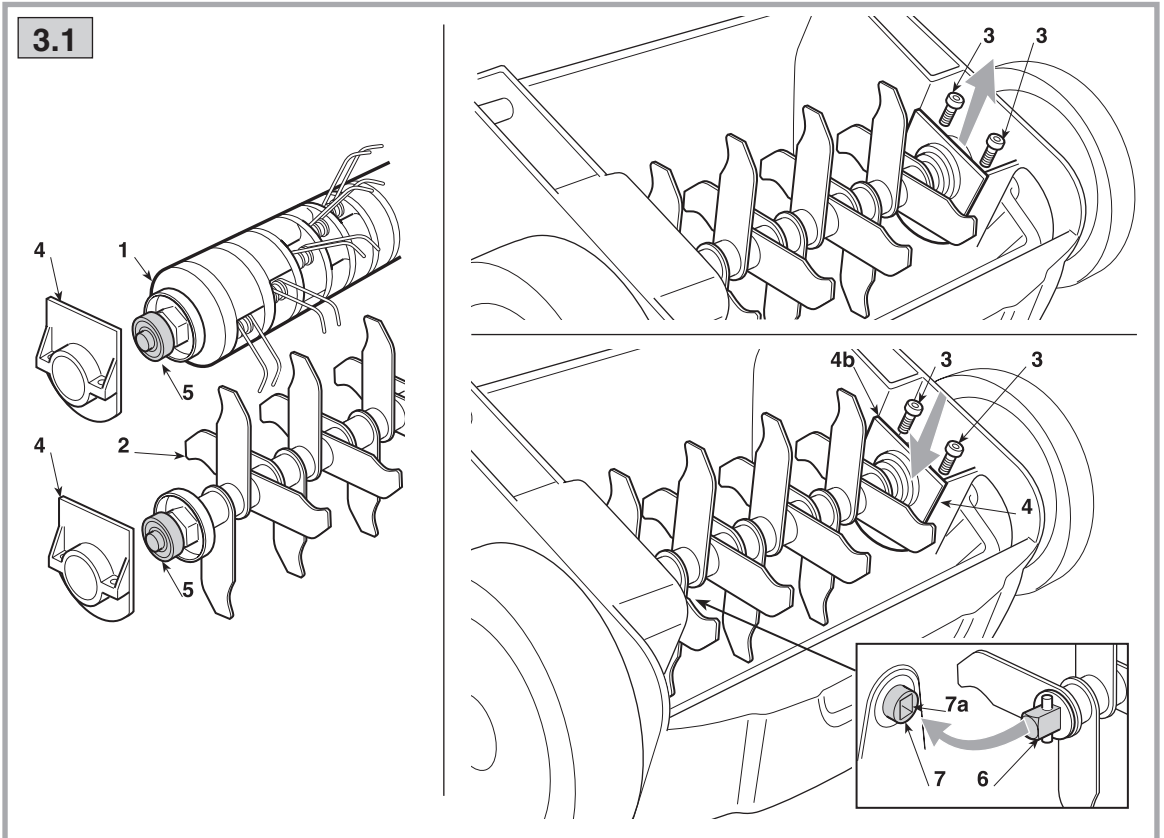
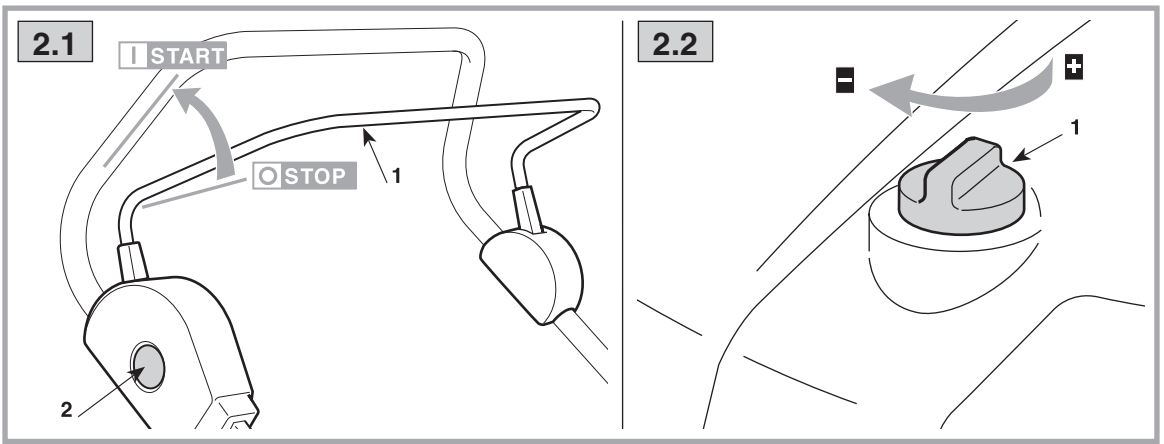

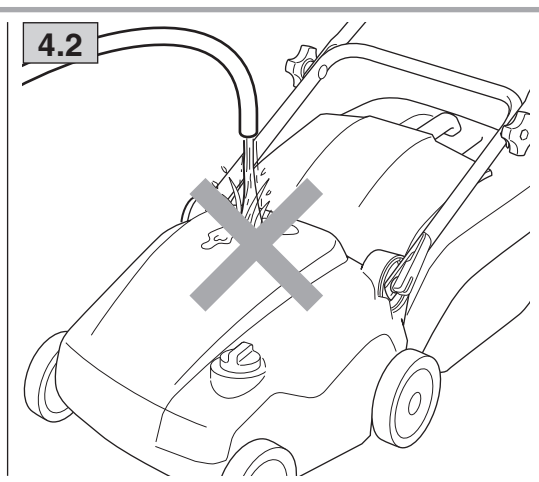
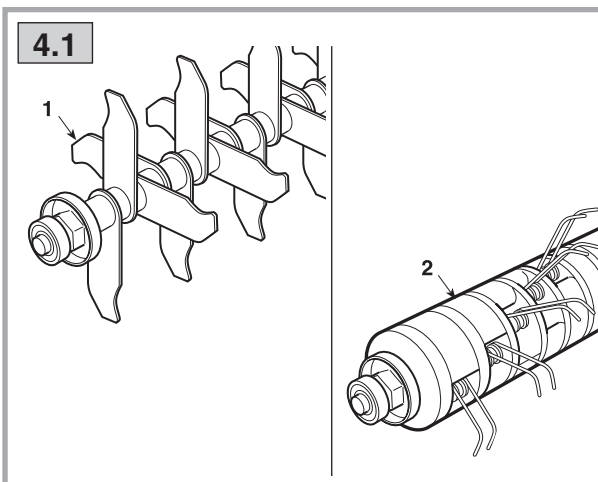
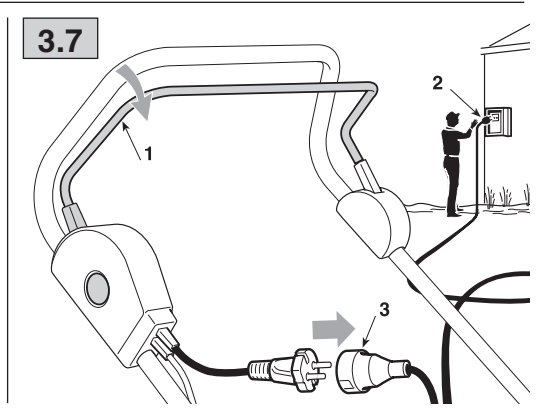
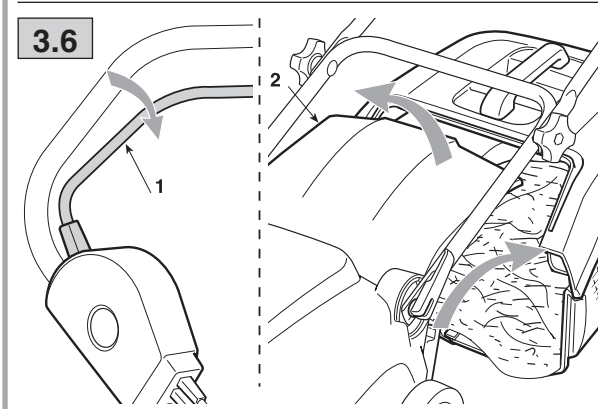
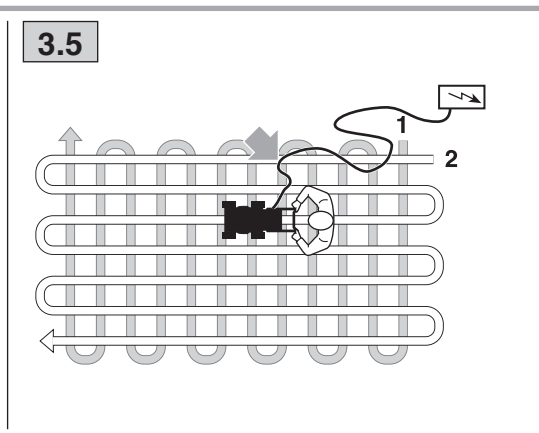
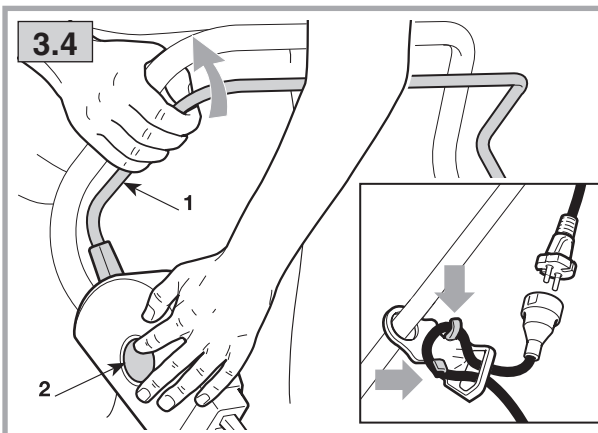

GETTING TO KNOW THE MACHINE

NOTE The images corresponding to the references are found on page 2 of this manual.

MACHINE DESCRIPTION AND USAGE

This machine is a garden tool, and precisely an electric aerator/scarifier, that is pedestrian controlled.

The machine is essentially composed of a motor which drives a tine rotor enclosed in a casing, equipped with wheels and a handle. The operator is able to operate the machine and use the main controls, always staying behind the handle at a safe distance from the rotating parts. If the operator leaves the machine, the motor and rotating parts will stop within a few seconds.

Intended use

This machine was designed and manufactured for aerating and scarifying the ground, done by a pedestrian operator. The difference of the effect made on the ground is obtained according to the structure of the interchangeable rotor tines and the depth in the ground.

Improper use

Any other use differing from the above mentioned ones could be hazardous and harm people and/or damage things. Examples of improper use may include, but are not limited to:

- transporting persons, children or animals on the machine;
- letting oneself be transported by the machine;
- using the machine to tow or push loads;
- use of the machine by more than one person;
- lowering or operating the rotor on firm surfaces or with gravel or stones.

IDENTIFICATION LABEL AND MACHINE COMPONENTS

1. Acoustic power level
2. Conformity marking
3. Year of manufacture
4. Type of machine
5. Serial number
6. Name and address of Manufacturer
7. Article Code
8. Motor power
9. Weight in kg
10. Power supply voltage and frequency
11. Handle
12. Motor
13. Tine rotor (with rigid blades or springs)
14. Stone-guard
15. Grass-catcher
16. Depth regulator
17. Control lever
18. Electric cable fitting

The example of the conformity declaration is found in the

penultimate page of the manual.

 Do not dispose of electrical equipment with household waste material. In observance of European Directive 2012/19/EC on waste electrical and electronic equipment and its implementation in accordance with national regulations, electric equipment that has reached the end of its product life must be collected separately and recycled in an ecologically compatible way. If electrical equipment is disposed of in dumps or in landfills, hazardous substances can leak into the groundwater and get into the food chain, damaging your health and well-being. For further information on the disposal of this product, contact a domestic waste collection authority or your Dealer.



Class II: Double insulation

DESCRIPTION OF SYMBOLS ON CONTROLS (where applicable)

21. Stop
22. Running

SAFETY REQUIREMENTS

Your machine must be used carefully. Symbols have therefore been placed on various parts of the machine to remind you of the main precautions to be taken. Their meaning is explained below. You are also asked to carefully read the safety regulations in the specific chapter of this manual. Replace damaged or illegible labels.

31. Warning: Read the instruction manual before using the machine.
32. Beware of sharp blades: The blades continue to turn even after the motor has been switched off. Disconnect the plug from the mains before commencing maintenance work or if the power cable is damaged.
33. Risk of thrown objects. Keep all persons away from the work area whilst working.
34. Warning: keep the power cable away from the rotor.
35. Risk of exposure to noise and dust. Wear protection against noise and protective glasses.
36. Unplug the machine immediately if the cable (or extension lead) is cut or damaged.

TECHNICAL DATA

- [61] Nominal power
- [62] Max. motor operation speed
- [63] Machine weight
- [64] Working width
- [65] Measured acoustic pressure level
- [66] Measurement uncertainty
- [67] Measured acoustic power level
- [68] Guaranteed acoustic power level
- [69] Measured vibration level
- [70] Code tine rotor with rigid blades
- [71] Code tine rotor with springs

SAFETY REGULATIONS to be observed scrupulously

A) TRAINING

- 1) Read the instructions carefully. Become familiar with the controls and the proper use of the machine. Learn how to stop the motor quickly.
- 2) Never allow children or persons unfamiliar with these instructions to use the machine. Local regulations can restrict the minimum age of the user.
- 3) Never use the machine:
 - when people, especially children or pets are nearby;
 - if the operator has taken medicine or substances that may impair his ability to react and be attentive.
- 4) Bear in mind that the operator or user is responsible for accidents or unexpected events occurring to other people or their property.

B) PRELIMINARY OPERATIONS

- 1) While working, always wear sturdy footwear and long trousers. Do not operate the machine when barefoot or wearing open sandals. Avoid wearing clothing that is loose fitting or has hanging cords or ties.
- 2) Thoroughly inspect the entire work area and remove anything that could be thrown by the machine or damage the cutting unit or motor (stones, branches, iron wire, bones, etc.).
- 3) Before use, always inspect generally and in particular to see that the rotating parts and cutting unit are not worn or damaged. Replace damaged or worn parts to preserve balance. Replace damaged or illegible labels.
- 4) Before use check the power and extension cable for signs of damage or aging.

C) DURING USE

- 1) Work only in daylight or good artificial light.
- 2) If possible, avoid mowing wet grass. Avoid working in the rain and when there is a thunderstorm risk. Do not use the machine in bad weather conditions, especially when there is risk of lightning.
- 3) Make sure you have a steady foothold on slopes.
- 4) Never run, always walk; do not let the machine pull you.
- 5) Always work transversely on slopes and never up and down.
- 6) Be extremely careful when changing directions on slopes.
- 7) Never work on overly steep slopes.
- 8) Be extremely careful when you pull the machine toward you.
- 9) Stop the rotating parts if the machine must be inclined for transport, when moving over surfaces other than grass and when the machine is transported from or to the work area.
- 10) Never operate the machine with damaged guards, or without the grass-catcher or stone-guard.
- 11) Start up the motor carefully according to the instructions, keeping feet away from the rotating parts.
- 12) Do not incline the machine when starting the motor, unless necessary for start up. In this event, do not incline it more than is absolutely necessary and only lift the part that is far from the operator. Always ensure that both hands are in the working position before lowering the machine again.
- 13) Never place your hands and feet near or under rotating parts.

- 14) Keep away from the discharge opening.
- 15) Do not lift or transport the machine when the motor is running.
- 16) Stop the machine and remove plug from the socket. Make sure that all moving parts have come to a complete stop:
 - whenever you leave the machine unattended;
 - before clearing blockages;
 - before checking, cleaning or working on the machine;
 - when transporting the machine;
 - after striking a foreign object. Inspect the machine for any damages and make the necessary repairs before using it again;
 - if the machine begins to vibrate abnormally.

If the machine begins to vibrate abnormally, proceed immediately to:

- inspect for damage;
 - check for and tighten any loose parts.
 - replace or repair any damaged parts at a specialised centre.
- 17) Stop the motor:
 - whenever you remove or reattach the grass-catcher;
 - before regulating the depth.

18) Do not use the machine if the cord is damaged or worn. If the cable or extension lead becomes damaged during use, disconnect the plug from the supply immediately. **DO NOT TOUCH THE CABLE BEFORE DISCONNECTING THE SUPPLY.**

19) Do not touch the rotating parts until the machine has been disconnected from the mains socket and that the rotating parts are completely still.

20) Keep the electric cable away from rotating parts. Rotating parts can damage the cable and cause electric contact with vital parts.

21) When working, always keep a safe distance from rotating parts, given by the length of the handle.

22) **WARNING** - If something breaks or an accident occurs while working, turn off the motor immediately and move the machine away to prevent further damage; if an accident occurs with injuries or third parties are injured, carry out the first aid measures most suitable for the situation immediately and contact the medical authorities for any necessary health care. Carefully remove any debris that might cause damage or harm persons or animals should it not be seen.

D) MAINTENANCE AND STORAGE

- 1) Keep all nuts and screws tight to be sure the machine is always in safe working condition. Routine maintenance is essential for safety and for maintaining a high performance level.
- 2) Check the stone-guard and grass-catcher frequently for wear or deterioration.
- 3) For safety reasons, never use the machine when it has worn or damaged parts. Parts must be replaced and not repaired. Use original spare parts. Parts that are not of the same quality can damage the machine and impair your safety.
- 4) Wear work gloves for disassembling and reassembling the rotor.
- 5) Parts subject to wear must only be replaced at a specialised centre.

E) ADDITIONAL WARNINGS

- 1) Power up the machine using a differential switch (RCD - Residual Current Device) with a tripping current of max. 30 mA.

2) The permanent connection of any electrical equipment to the mains of a building must be installed by a qualified electrician in conformity with the regulations in force. Incorrect wiring can cause serious injury and even death.

3) **WARNING: DANGER!** Moisture and electricity are not compatible:

- always handle and connect electric cables in dry conditions;
- never allow electric sockets or cables to contact wet areas (puddles or wet grass);
- connections between cables and sockets must always be watertight. Only use extension leads with intact, watertight and approved sockets sold on the market.

4) The quality of the extension leads must be no less than H05RN-F or H05VV-F, with a minimum section of 1.5 mm² and a recommended maximum length of 25 m.

5) Never use the machine if the power cable or extension lead are damaged or worn.

6) Never connect a damaged cable to a mains socket and never touch a damaged cable that is connected to the mains socket. Damaged or deteriorated cables may cause contact with energised parts.

7) Attach the extension lead to the cable fastener, before starting the machine. Use the cable fastener to prevent the cable from disconnecting accidentally as indicated in this manual. Make sure it is connected to the socket without being forced.

8) Keep extension cords away from the tines. The tines can cause damage to the cords and lead to contact with live parts.

9) Never pull the machine by its power cable or use the cable to pull the plug. Do not expose the cable to sources of heat, or let it come into contact with oil, solvents and sharp objects.

F) TRANSPORTATION AND HANDLING

1) Whenever the machine is to be handled, lifted, transported or tilted you must:

- wear sturdy work gloves;
- grasp the machine at the points that offer a safe grip, taking account of the weight and its distribution.
- use an appropriate number of people for the weight of the machine and the characteristics of the vehicle or the place where it must be placed or collected.

2) During transport, fasten the machine securely with cables or chains.

OPERATING INSTRUCTIONS

NOTE The number which precedes each paragraph links the references in the text to the respective illustrations (listed on page 2 and following pages).

1. COMPLETE ASSEMBLY

NOTE The machine can be supplied with some parts already assembled.

WARNING - Unpacking and completing the assembly should be done on a flat and stable surface, with enough space for moving the machine and its packaging, always using suitable equipment. Disposal of the packaging should be done in accordance with the local regulations in force.

1.1 HANDLE ASSEMBLY

Fit the two toothed discs (1) to the two ends of the bottom of the handle (2) and insert them in their seats (3) in the chassis, taking care to correctly insert the protrusion (1a) of the disc (1) in the compartment (3a) of the seat (3).

Fasten the bottom (2) to the chassis using the two knobs (4). These knobs must be tightened enough to ensure that the handle is firmly attached, without requiring excessive force to loosen or tighten them again when the handle height must be adjusted, with respect to the operator's height.

Attach the two middle elements (5) to the bottom (2) using the knobs (6) and the supplied screws as shown.

Insert the cable fastener (7) in the indicated position and fit the top of the handle (8) using the knobs (6) and the supplied screws as shown.

Fit the cable fastener (9) in the indicated position and attach the electric cable (10).

To adjust the height of the handle with respect to the operator's height, loosen the knobs (4), lift or lower the handle to the desired height then tighten the knobs (4).

1.2 FITTING THE GRASS-CATCHER

Join the two side components (1) and (2) of the grass-catcher together, then fit the upper part (3), inserting all the outside couplings correctly.

2. CONTROL DESCRIPTION

NOTE The meanings of the symbols on controls are explained in the previous pages.

2.1 DUAL-ACTION SWITCH

The motor is controlled by a dual-action switch to prevent accidental start ups.

Press the button (2) and pull the lever (1) for start up.

WARNING - Starting up the motor will engage the rotor contemporaneously.

The motor stops automatically when the lever (1) is released.

2.2 DEPTH REGULATOR

The knob (1) allows the rotor position to be regulated to different heights, thereby varying the depth of the rotor tines in the ground.

Regulation is completed with 2 complete turns of the knob, equal to a total movement of approximately 18 mm:

- tightening (clockwise) the rotor is lowered;
- loosening (anticlockwise) the rotor is raised.

WARNING - The rotor only be regulated with the motor off and the rotor stopped.

3. USING THE MACHINE

3.1 SETTING UP THE ROTOR

The machine is equipped with two different tine rotors, to be used according to the type of work to be done:

- with springs (1) for raking and surface aeration of the ground;
 - with rigid blades (2) for scarifying the ground.
- To disassemble the rotor:
- unplug the machine from the mains;
 - wear work gloves and turn the machine over;
 - loosen the two screws (3) on the right side of the machine;
 - lift the rotor from the right side and extract it from the left side.
 - remove the plastic support (4).

To reassemble the rotor:

- fit the plastic support (4) on the bearing (5) located on the end of the rotor;
- first insert the left end (6) of the rotor in the protruding shaft (7), making sure it fits perfectly in the shaft slot (7a).
- insert the right end with the support (4) in its housing, with the flat part (4b) turned outward.
- reassemble and fully tighten the two screws (3).

3.2 REGULATING DEPTH

Select the depth according to the type of work mode and the type of rotor used, following these basic indications, referring to the completely lifted position of the rotor (knob as far as possible anticlockwise):

- «1» = knob as far as possible anticlockwise = Transfer (for moving the machine, with the rotor lifted that does not touch the ground).
- «2» = knob 1/2 turn clockwise = With rotor with springs and grass-catcher, for raking leaves and grass on the surface and for aerating the ground, collecting removed material;
- «2» «3» = knob 1/2 or 1 turn clockwise = With the rotor with rigid blades and grass-catcher, for scarifying the surface of the ground, collecting removed material;
- «4» «5» = knob 1 and 1/2 turns or 2 turns clockwise = With the rotor with rigid blades and no grass-catcher, for more or less deep scarification of the ground, leaving removed material on the ground; In optimal conditions, the grass-catcher can be fitted and the removed material can be collected, as long as the rotor is not clogged.

3.3 FITTING THE GRASS-CATCHER

Lift the stone-guard (1) and fasten the grass-catcher (2) correctly as shown in the illustration.

3.4 STARTING

Fasten the extension cable correctly as shown. To start the motor, push the safety button (2) and pull the switch lever (1).

3.5 AERATING AND SCARIFYING THE GROUND

While working, make sure the electric cable is always behind you and on the side of the area you have finished. Two crossed passages, a week apart, will give the best results.

Lawn care suggestions

- Over time, a layer of moss and grass residue forms on the ground surface reducing its supply of oxygen and stopping water and nutritious substances from penetrating. This impoverishes the lawn and makes it yellow.
- The ideal period for aerating and scarifying a lawn is in autumn or spring.
- Optimal working conditions consist of low and slightly wet grass, as working on ground that is dry or softened with too much water impedes collection of material and may damage the lawn.
- It is always advisable to remove leaves from the lawn before aerating or scarifying.
- You can remove that surface felt with a surface aerating action (with reduced tine depth in the ground).
- By increasing depth (scarifying), that removal action involves the harder ground layer and, at the same time, separates grass roots and increases them. This makes your lawn thicker with more blades of grass.

3.6 EMPTYING THE GRASS-CATCHER

To remove and empty the grass-catcher,

- release the switch lever (1) and wait for the rotor to stop;
- lift the stone-guard (2), grasp the handle and remove the grass-catcher keeping it in an erect position.

3.7 WHEN WORK IS FINISHED

Release the lever (1) when work has been completed. Disconnect the extension cable FIRST from the general socket (2) THEN from the side of the machine switch (3).

WAIT UNTIL THE ROTOR STOPS before making any adjustments to the machine.

IMPORTANT *If the motor stops because it is overheated while working, you must wait about 5 minutes before restarting it.*

4. ROUTINE MAINTENANCE

IMPORTANT *Routine and accurate maintenance is essential in maintaining original machine safety and performance levels.*

Store the machine in a dry place.

- 1) Wear sturdy work gloves before cleaning, maintaining or adjusting the machine.
- 2) Clean the machine after each use; remove debris and mud accumulated on the rotor and on tines, to prevent it drying and making the next removal difficult.
- 3) Avoid using petrol or solvents on the plastic parts of the machine to prevent damaging them. The warranty does not cover damage to plastic parts caused by the use of petrol or solvents.

4.1 ROTOR MAINTENANCE

Tine rotors are composed of different elements that are factory assembled and cannot be replaced individually by the user; if a blade or spring breaks, you must replace the entire rotor or contact your Dealer for repair work. Replacements must be made according to the indications at point 3.1.

Rotors with rigid blades (1) or springs (2) bearing the code indicated on the chart on page 2 should be used on this machine.

Given product evolution, the above mentioned rotors may be replaced in time with others having similar interchangeable and operating safety features.

4.2 CLEANING THE MACHINE

Do not spray water onto and avoid wetting the motor and electrical components.

Do not use aggressive liquids to clean the chassis.

5. ENVIRONMENTAL PROTECTION

Environmental protection should be a priority of considerable importance when using the machine, for the benefit of both social coexistence and the environment in which we live.

- Try not to cause any disturbance to the surrounding area.
- Scrupulously comply with local regulations for the disposal of waste materials after working.
- Scrupulously comply with local regulations for the disposal of packaging, deteriorated parts or any elements with a strong environmental impact; this waste must not be disposed of as normal waste, it must be separated and taken to specified waste disposal centres where the material will be recycled.
- When decommissioning, do not pollute the environment with the machine, hand it over to a disposal centre, in accordance with the local regulations in force.

6. DIAGNOSTICS

What to do when ...	
Source of problem	Corrective action
1. The machine does not work	
Electric current does not reach the machine	Check the electrical connection
2. The current cuts off when the machine is started	
The mains socket amperage is not sufficient	Connect the machine to a mains socket with sufficient amperage
Other electrical appliances are working	Do not connect other appliances to the same mains socket at the same time
3. The machine stops during work	
The protection device triggers	Wait at least 5 minutes before restarting the motor
4. The machine stops frequently during work or it does not operate in a regular manner	
Demanding working conditions	Check that the rotor has been regulated accordingly with the conditions of the lawn and/or regulate it to a higher level
The tine rotor is clogged	Unplug the machine from the mains, put on protective gloves and clean the rotor and surrounding area
	Reduce the quantity of removed material reducing the depth of the rotor.
The grass-catcher is clogged	Empty the grass-catcher regularly before it fills completely
5. Poor and unsatisfactory performance levels	
Tine rotor with worn or missing blades or springs	Replace the rotor with an original part
Grass too tall	Cut the grass to an adequate height
Ground too wet	Regulate the rotor to a higher level or postpone work until ground conditions improve

For any doubts or problems, please do not hesitate to contact your nearest Customer Service Centre or Your Dealer.

DICHIARAZIONE CE DI CONFORMITÀ (Istruzioni Originali)
(Direttiva Macchine 2006/42/CE, Allegato II, parte A)

1. **La Società:** STIGA SpA – Via del Lavoro, 6 – 31033 Castelfranco Veneto (TV) – Italy
2. Dichiaro sotto la propria responsabilità, che la macchina: Aeratore-Scarificatore elettrico alimentato dalla rete condotto a piedi / aeratura-scaricatura terreno

a) Tipo / Modello Base

SV 415 E

b) Mese/Anno di costruzione

c) Matricola

d) Motore

elettrico

3. È conforme alle specifiche delle direttive:

- MD: 2006/42/EC
 - e) Ente Certificatore: /
 - f) Esame CE del tipo: /
- OND: 2000/14/EC, ANNEX V
D. Lgs. 262/2002, ANNEX V (Italy)
 - e) Ente Certificatore: /
- EMCD: 2014/30/EU
- RoHS II: 2011/65/EU

4. Riferimento alle Norme armonizzate:

EN 60335-1:2012/A11:2014
EN 50636-2-92:2014
EN 50581:2012

EN 55014-1:2006+A1:2009+A2:2011
EN 55014-2:1997+A1:2001+A2:2008
EN 64000-3-2:2014
EN 61000-3-3:2013

- g) Livello di potenza sonora misurato
h) Livello di potenza sonora garantito
k) Potenza installata

90 dB(A)
94 dB(A)
1,5 kW

n) Persona autorizzata a costituire il Fascicolo Tecnico:

STIGA SpA
Via del Lavoro, 6
31033 Castelfranco Veneto (TV)- Italia

o) Castelfranco V.to, 01.10.2017

R&D Director
Franco Bastasin



DICHIARAZIONE CE DI CONFORMITÀ (Istruzioni Originali)
(Direttiva Macchine 2006/42/CE, Allegato II, parte A)

1. **La Società:** STIGA SpA – Via del Lavoro, 6 – 31033 Castelfranco Veneto (TV) – Italy
2. Dichiaro sotto la propria responsabilità, che la macchina: Aeratore-Scarificatore elettrico alimentato dalla rete condotto a piedi / aeratura-scaricatura terreno

a) Tipo / Modello Base

SC 1.5 E

b) Mese/Anno di costruzione

c) Matricola

d) Motore

elettrico

3. È conforme alle specifiche delle direttive:

- MD: 2006/42/EC
e) Ente Certificatore: /
f) Esame CE del tipo: /
- OND: 2000/14/EC, ANNEX V
D. Lgs. 262/2002, ANNEX V (Italy)
e) Ente Certificatore: /
- EMCD: 2014/30/EU
- RoHS II: 2011/65/EU

4. Riferimento alle Norme armonizzate:

EN 60335-1:2012/A11:2014
EN 50636-2-92:2014
EN 50581:2012

EN 55014-1:2006+A1:2009+A2:2011
EN 55014-2:1997+A1:2001+A2:2008
EN 64000-3-2:2014
EN 61000-3-3:2013

- g) Livello di potenza sonora misurato
h) Livello di potenza sonora garantito
k) Potenza installata

90 dB(A)
94 dB(A)
1,5 kW

n) Persona autorizzata a costituire il Fascicolo Tecnico:

STIGA SpA
Via del Lavoro, 6
31033 Castelfranco Veneto (TV)- Italia

o) Castelfranco V.to, 01.10.2017

R&D Director
Franco Bastasin



FR (Traduction de la notice originale)	EN (Translation of the original instruction)	DE (Übersetzung der Originalanweisung)	NO (Oversattelse av original brukermanual)	BV (Översättning av bruksanvisning i original)	DA (Oversættelse af den originale brugermanual)
<p>Declaration CE de Conformité (Directive Machines 2006/42/CE, Annex A, partie A)</p> <p>1. La Société 2. Docteur sous sa propre responsabilité ou sa machine : a) Type / Modèle de Base b) Motor: moteur électrique c) Batterie d) Motor: électrique e) Motor: moteur essence 3. Est conforme aux prescriptions des directives: a) Directive de certification b) Norme CE de la Type c) Norme des normes harmonisées d) Niveau de puissance sonore mesuré e) Niveau de puissance sonore garanti f) Performances acoustiques g) Performances habitables à établir le Dossier Technique h) Liste de Data</p>	<p>EC Declaration of Conformity (Machine Directive 2006/42/EC, Annex A, part A)</p> <p>1. The Company 2. Myself under my own responsibility or the machine: a) Type / Model of Base b) Motor: battery-operated c) Motor: electric d) Engine: petrol 3. Conforms to directive specifications: a) CE marking b) Reference to harmonized Standards c) Sound power level measured d) Sound power level guaranteed e) Measured sound power f) Guaranteed sound power g) Place and date</p>	<p>CE-Konformitätserklärung (Maschinenrichtlinie 2006/42/EG, Anhang II, Teil A)</p> <p>1. Die Gesellschaft 2. EMKist auf eigenen Verantwortung, das die Maschine: a) Typ / Basismodell b) Motor: Batterie c) Serienmotor d) Motor: elektrisch e) Motor: Verbrennungsmotor 3. Die Anforderungen der folgenden Richtlinien sind erfüllt: a) Zertifizierungsverfahren b) CE-Markierung c) Bezugnahme auf die harmonisierten Normen d) Gemessene Schallleistung e) Garantierte Schallleistung f) Zusätzliche Angaben g) Technische Unterlagen h) Liste der Daten</p>	<p>EF - Samvaretsavtale (Maskineriktlinje 2006/42/EF, Vedlegg II, del A)</p> <p>1. Firmaet 2. Enten selv eller ansvaret for maskinen: a) Type / Modell b) Motor: batteridrevet c) Serienmotor d) Motor: elektrisk e) Motor: forbræningsmotor 3. Oppfylger kravene i direktivene: a) Sertifiseringsprosedyren b) Referansen til harmoniserte standarder c) Målte lydverdi d) Garanterte lydverdi e) Målte lydverdi f) Ytterligere opplysninger g) Tekniske dokumenter h) Liste på dato</p>	<p>EF-överensstämmelse (Maskineriktlinje 2006/42/EG, bilaga II, del A)</p> <p>1. Företaget 2. Enten själv eller ansvaret för maskinen: a) Typ / Basmodell b) Motor: batteridrivad c) Serienmotor d) Motor: elektrisk e) Motor: förbränningsmotor 3. Överensstämmer med direktivens krav: a) Certifieringsförfarandet b) Referens till harmoniserade standarder c) Mätta ljudvärden d) Garanterade ljudvärden e) Mätta ljudvärden f) Ytterligare uppgifter g) Tekniska dokumentation h) Lista på datum</p>	<p>EF-overensstemmelse (Maskineriktlinje 2006/42/EF, vedlegg II, del A)</p> <p>1. Firmaet 2. Enten selv eller ansvaret for maskinen: a) Type / Modell b) Motor: batteridrevet c) Serienmotor d) Motor: elektrisk e) Motor: forbræningsmotor 3. EF-overensstemmer med direktivets krav: a) Certifieringsprosedyren b) Referansen til harmoniserte standarder c) Målte lydverdi d) Garanterte lydverdi e) Målte lydverdi f) Ytterligere opplysninger g) Tekniske dokumentasjon h) Liste på dato</p>

NL (Vertaling van de oorspronkelijke gebruiksaanwijzing)	ES (Traducción del Manual Original)	FR (Traduction de la notice originale)	IT (Traduzione del manuale d'istruzioni)	PL (Tłumaczenie instrukcji oryginalnej)
<p>EC-Verklaring van overeenstemming (Richtlijn Machines 2006/42/EG, Bijlage II, deel A)</p> <p>1. Verklaart onder zijn eigen verantwoordelijkheid de machine: a) Type / Basismodel b) Motor: Benzine c) Serienmotor d) Motor: elektrisch e) Motor: benzinemotor 3. Verklaart aan de specificaties van de richtlijn: a) Certificeringsprocedure b) Referentie naar de geharmoniseerde normen c) Gemiddelde geluidvermogen d) Garandeerd vermogen e) Technische gegevens f) Plaats en datum</p>	<p>Declaración de Conformidad CE (Directiva Máquinas 2006/42/CE, Anexo II, parte A)</p> <p>1. La Empresa 2. Declara bajo su propia responsabilidad que la máquina: a) Tipo / Modelo Base b) Motor: Motor de gasolina c) Motor: eléctrico d) Motor: motor de explosión 3. Cumple con las especificaciones de las directivas: a) Procedimiento de certificación b) Referencia a las normas armonizadas c) Nivel de potencia sonora garantado d) Nivel de potencia sonora permitida e) Datos técnicos f) Persona autorizada a realizar el Manual Técnico g) Lugar y Fecha</p>	<p>CE-Verklaring van overeenstemming (Richtlijn Machines 2006/42/EG, Bijlage II, deel A)</p> <p>1. Verklaart onder zijn eigen verantwoordelijkheid de machine: a) Type / Basismodel b) Motor: Benzine c) Serienmotor d) Motor: elektrisch e) Motor: benzinemotor 3. Verklaart aan de specificaties van de richtlijn: a) Certificeringsprocedure b) Referentie naar de geharmoniseerde normen c) Gemiddelde geluidvermogen d) Garandeerd vermogen e) Technische gegevens f) Plaats en datum</p>	<p>CE-Verklaring van overeenstemming (Richtlijn Machines 2006/42/EG, Bijlage II, deel A)</p> <p>1. Verklaart onder zijn eigen verantwoordelijkheid de machine: a) Type / Basismodel b) Motor: Benzine c) Serienmotor d) Motor: elektrisch e) Motor: benzinemotor 3. Verklaart aan de specificaties van de richtlijn: a) Certificeringsprocedure b) Referentie naar de geharmoniseerde normen c) Gemiddelde geluidvermogen d) Garandeerd vermogen e) Technische gegevens f) Plaats en datum</p>	<p>CE-Verklaring van overeenstemming (Richtlijn Machines 2006/42/EG, Bijlage II, deel A)</p> <p>1. Verklaart onder zijn eigen verantwoordelijkheid de machine: a) Type / Basismodel b) Motor: Benzine c) Serienmotor d) Motor: elektrisch e) Motor: benzinemotor 3. Verklaart aan de specificaties van de richtlijn: a) Certificeringsprocedure b) Referentie naar de geharmoniseerde normen c) Gemiddelde geluidvermogen d) Garandeerd vermogen e) Technische gegevens f) Plaats en datum</p>

EL (Πρόσβαση του πρωτότυπου της οδηγίας χρήσης)	TR (Original talimatları Türkçeye çevirmek)	UK (Прочитать оригинал инструкции пользователя)	HU (Eredeti használati utasítás fordítása)	RU (Перевести оригинал инструкции пользователя)	HR (Prijaviti originalni uputebe)
<p>ΕΚΔΗΛΩΣΗ ΣΥΜΜΟΡΦΗΣ (Οδηγία Μηχανών 2006/42/ΕΚ, Παράρτητο II, μέρος Α)</p> <p>1. Η Εταιρεία 2. Δήλώνει ενόψει της δικής της ευθύνης: a) Τύπος / Μοντέλο Βασικό b) Μотор: Ηλεκτρικό c) Αλληλόμετρο d) Κεντρικό / Ηλεκτρικό e) Κεντρικό / Μотор: Βενζινοκίνητο 3. Δηλώνει ότι συμμορφώνεται με τις οδηγίες: a) Διαδικασία πιστοποίησης b) Αναφορά στις αρμονισμένες οδηγίες c) Ανεπιβεβαιωμένο επίπεδο ηχητικής ισχύος d) Επιβεβαιωμένο επίπεδο ηχητικής ισχύος e) Τεχνικά στοιχεία f) Τόπος και ημερομηνία</p>	<p>AT Uygulama Beyanı (2006/42/AT Makine Direktifi, Ek II, bölüm A)</p> <p>1. Şirket 2. Kendi sorumluluğunda aşağıdaki makineyi: a) Tip / Model de baz b) Motor: elektrik c) Motor: benzinli 3. Bu talimatların gerektirdiği özelliklere uyumlu olduğunu beyan eder: a) Sertifikasyon prosedürü b) Harmonize edilmiş standartlara referans c) Ses gücü seviyesi garanti edilmiş d) Ses gücü seviyesi izin verilen e) Teknik özellikler f) Yeri ve tarih</p>	<p>Декларация за съответствие с ДВ (Директива за машини 2006/42/ЕО, в част А)</p> <p>1. Компанията 2. Декларирам под своя отговорност, че машината: a) Тип / Основен модел b) Мотор: електричен c) Мотор: бензинов 3. Декларирам съответствието си с директивата: a) Процедура за сертификация b) Справка за хармонизираните норми c) Гарантирано ниво на звуковата мощност d) Гарантирано ниво на звуковата мощност e) Технически данни f) Място и дата</p>	<p>EC megjelölés nyilatkozata (2006/42/EK gépjárműv, II. melléklet "A" rész)</p> <p>1. Alulírott vállalom 2. Felelősségemteljesítéssel kijelentem, hogy az alábbi gép: a) Típus / Alapmodell b) Motor: áramos c) Áramos / Motor: benzin 3. Megjelölöm, hogy megfelel az alábbi irányelv követelményeinek: a) A tanúsítási eljárás b) A harmonizált normákra való hivatkozás c) A zajteljesítmény garantált értéke d) A zajteljesítmény megengedett értéke e) A műszaki adatok f) A helyszín és a dátum</p>	<p>Декларация за съответствие с Директивата за машини 2006/42/ЕО, Част А</p> <p>1. Компанията 2. Заявявам под своя отговорност, че машината: a) Тип / Основен модел b) Мотор: Електричен c) Мотор: Бензинов 3. Заявявам съответствието си с директивата: a) Процедурата за сертификация b) Справка за хармонизираните норми c) Гарантирано ниво на звуковата мощност d) Гарантирано ниво на звуковата мощност e) Технически данни f) Място и дата</p>	<p>CE-Verklaring van overeenstemming (Richtlijn Machines 2006/42/EG, Bijlage II, deel A)</p> <p>1. Verklaart onder zijn eigen verantwoordelijkheid de machine: a) Type / Basismodel b) Motor: Benzine c) Serienmotor d) Motor: elektrisch e) Motor: benzinemotor 3. Verklaart aan de specificaties van de richtlijn: a) Certificeringsprocedure b) Referentie naar de geharmoniseerde normen c) Gemiddelde geluidvermogen d) Garandeerd vermogen e) Technische gegevens f) Plaats en datum</p>

ES (Traducción de la nota original)	ES (Traducción de la nota original)	ES (Traducción de la nota original)
<p>ES-Verklaring van overeenstemming (Richtlijn Machines 2006/42/EG, bijlage II, deel A)</p> <p>1. Firma 2. Verklaart onder mijn eigen verantwoordelijkheid de machine: a) Type / Basismodel b) Motor: elektrisch c) Motor: benzine 3. Verklaart aan de specificaties van de richtlijn: a) Certificeringsprocedure b) Referentie naar de geharmoniseerde normen c) Gemiddelde geluidvermogen d) Garandeerd vermogen e) Technische gegevens f) Plaats en datum</p>	<p>ES-Verklaring van overeenstemming (Richtlijn Machines 2006/42/EG, bijlage II, deel A)</p> <p>1. Firma 2. Verklaart onder mijn eigen verantwoordelijkheid de machine: a) Type / Basismodel b) Motor: elektrisch c) Motor: benzine 3. Verklaart aan de specificaties van de richtlijn: a) Certificeringsprocedure b) Referentie naar de geharmoniseerde normen c) Gemiddelde geluidvermogen d) Garandeerd vermogen e) Technische gegevens f) Plaats en datum</p>	<p>ES-Verklaring van overeenstemming (Richtlijn Machines 2006/42/EG, bijlage II, deel A)</p> <p>1. Firma 2. Verklaart onder mijn eigen verantwoordelijkheid de machine: a) Type / Basismodel b) Motor: elektrisch c) Motor: benzine 3. Verklaart aan de specificaties van de richtlijn: a) Certificeringsprocedure b) Referentie naar de geharmoniseerde normen c) Gemiddelde geluidvermogen d) Garandeerd vermogen e) Technische gegevens f) Plaats en datum</p>

RO (Traducerea manualului de fabricație)	LT (Originali instrukcija vertimas)	SK (Překlad originálního návodu na český)
<p>CE-Declaratie de Conformitate (Directiva Mașini 2006/42/CE, Anexa II, partea A)</p> <p>1. Societatea 2. Declara în propria răspundere că mașina: a) Tip / Model de bază b) Motor: electric c) Motor: benzina 3. Este în conformitate cu specificațiile directivei: a) Organism de certificare b) Normele CE de tip c) Referință la standardele armonizate d) Nivelul de putere sonoră garantat e) Nivelul de putere sonoră permis f) Date tehnice g) Persoana autorizată să realizeze Documentul Tehnic h) Locul și Data</p>	<p>ES-Verklaring van overeenstemming (Richtlijn Machines 2006/42/EG, bijlage II, deel A)</p> <p>1. Firma 2. Verklaart onder mijn eigen verantwoordelijkheid de machine: a) Type / Basismodel b) Motor: elektrisch c) Motor: benzine 3. Verklaart aan de specificaties van de richtlijn: a) Certificeringsprocedure b) Referentie naar de geharmoniseerde normen c) Gemiddelde geluidvermogen d) Garandeerd vermogen e) Technische gegevens f) Plaats en datum</p>	<p>ES-Verklaring van overeenstemming (Richtlijn Machines 2006/42/EG, bijlage II, deel A)</p> <p>1. Firma 2. Verklaart onder mijn eigen verantwoordelijkheid de machine: a) Type / Basismodel b) Motor: elektrisch c) Motor: benzine 3. Verklaart aan de specificaties van de richtlijn: a) Certificeringsprocedure b) Referentie naar de geharmoniseerde normen c) Gemiddelde geluidvermogen d) Garandeerd vermogen e) Technische gegevens f) Plaats en datum</p>

RO (Traducerea manualului de fabricație)	BG (Прочетете оригиналните инструкции)	ET (Ajakirja kääntäminen suomeksi)
<p>CE-Declaratie de Conformitate (Directiva Mașini 2006/42/CE, Anexa II, partea A)</p> <p>1. Societatea 2. Declara în propria răspundere că mașina: a) Tip / Model de bază b) Motor: electric c) Motor: benzina 3. Este în conformitate cu specificațiile directivei: a) Organism de certificare b) Normele CE de tip c) Referință la standardele armonizate d) Nivelul de putere sonoră garantat e) Nivelul de putere sonoră permis f) Date tehnice g) Persoana autorizată să realizeze Documentul Tehnic h) Locul și Data</p>	<p>ES-Verklaring van overeenstemming (Richtlijn Machines 2006/42/EG, bijlage II, deel A)</p> <p>1. Firma 2. Verklaart onder mijn eigen verantwoordelijkheid de machine: a) Type / Basismodel b) Motor: elektrisch c) Motor: benzine 3. Verklaart aan de specificaties van de richtlijn: a) Certificeringsprocedure b) Referentie naar de geharmoniseerde normen c) Gemiddelde geluidvermogen d) Garandeerd vermogen e) Technische gegevens f) Plaats en datum</p>	<p>ES-Verklaring van overeenstemming (Richtlijn Machines 2006/42/EG, bijlage II, deel A)</p> <p>1. Firma 2. Verklaart onder mijn eigen verantwoordelijkheid de machine: a) Type / Basismodel b) Motor: elektrisch c) Motor: benzine 3. Verklaart aan de specificaties van de richtlijn: a) Certificeringsprocedure b) Referentie naar de geharmoniseerde normen c) Gemiddelde geluidvermogen d) Garandeerd vermogen e) Technische gegevens f) Plaats en datum</p>

RO (Traducerea manualului de fabricație)	BG (Прочетете оригиналните инструкции)	ET (Ajakirja kääntäminen suomeksi)
<p>CE-Declaratie de Conformitate (Directiva Mașini 2006/42/CE, Anexa II, partea A)</p> <p>1. Societatea 2. Declara în propria răspundere că mașina: a) Tip / Model de bază b) Motor: electric c) Motor: benzina 3. Este în conformitate cu specificațiile directivei: a) Organism de certificare b) Normele CE de tip c) Referință la standardele armonizate d) Nivelul de putere sonoră garantat e) Nivelul de putere sonoră permis f) Date tehnice g) Persoana autorizată să realizeze Documentul Tehnic h) Locul și Data</p>	<p>ES-Verklaring van overeenstemming (Richtlijn Machines 2006/42/EG, bijlage II, deel A)</p> <p>1. Firma 2. Verklaart onder mijn eigen verantwoordelijkheid de machine: a) Type / Basismodel b) Motor: elektrisch c) Motor: benzine 3. Verklaart aan de specificaties van de richtlijn: a) Certificeringsprocedure b) Referentie naar de geharmoniseerde normen c) Gemiddelde geluidvermogen d) Garandeerd vermogen e) Technische gegevens f) Plaats en datum</p>	<p>ES-Verklaring van overeenstemming (Richtlijn Machines 2006/42/EG, bijlage II, deel A)</p> <p>1. Firma 2. Verklaart onder mijn eigen verantwoordelijkheid de machine: a) Type / Basismodel b) Motor: elektrisch c) Motor: benzine 3. Verklaart aan de specificaties van de richtlijn: a) Certificeringsprocedure b) Referentie naar de geharmoniseerde normen c) Gemiddelde geluidvermogen d) Garandeerd vermogen e) Technische gegevens f) Plaats en datum</p>

IT • Il contenuto e le immagini del presente manuale d'uso sono stati realizzati per conto di STIGA SpA e sono tutelati da diritto d'autore – E' vietata ogni riproduzione o alterazione anche parziale non autorizzata del documento.

BG • Съдържанието и изображенията в настоящото ръководство са извършени за STIGA SpA и са защитени с авторски права – Забранява се всяко неотризирано възпроизвеждане или промяна, дори и отчасти на документа.

BS • Sadržaj i slike iz ovog korisničkog priručnika napravljeni su isključivo za STIGA SpA i zaštićeni su autorskim pravima – zabranjena je svaka neovlaštena reprodukcija ili izmjena dokumenta, djelomično ili u potpunosti.

CS • Obsah a obrázky v tomto návodu k použití byly zpracovány jménem společnosti STIGA SpA a jsou chráněny autorským právem – Reprodukce či nepovolené pozměňování tohoto dokumentu, a to i částečně, je zakázáno.

DA • Indhold og illustrationer i denne vejledning er blevet skabt på vegne af STIGA SpA og er beskyttet af ophavsret – Enhver gengivelse eller ændring, også delvis, af dokumentet uden autorisation hertil er forbudt.

DE • Inhalt und Bilder dieser Bedienungsanleitung wurden im Namen von STIGA SpA erstellt und sind urheberrechtlich geschützt – Jede nicht genehmigte Vervielfältigung oder Veränderung, auch auszugsweise, dieses Dokument ist verboten.

EL • Το περιεχόμενο και οι εικόνες στο παρόν εγχειρίδιο χρήσης δημιουργήθηκαν για λογαριασμό της εταιρείας STIGA SpA και προστατεύονται από πνευματικά δικαιώματα – Απαγορεύεται οποιαδήποτε αναπαραγωγή ή τροποποίηση, έστω και μερική, του εγγύρφου χωρίς έγκριση.

EN • The content and images in this User Manual were produced expressly for STIGA SpA and are protected by copyright – any unauthorised reproduction or modification to the document, either partially or in full, is prohibited.

ES • El contenido y las imágenes del presente manual de uso han sido creados por STIGA SpA y están protegidos por los derechos de autor – Se prohíbe toda reproducción o modificación, incluso parcial, no autorizada del documento.

ET • Käesoleva kasutusjuhendi sisu ja kujutised on toodetud konkreetselt ettevaltole STIGA SpA ja neile rakendud autorikaitseasendus – dokumendi igasugune osaline või täielik ilma loata reprodutseerimine või muutmine on keelatud.

FI • Tämän käyttöoppaan sisältö ja kuvat on valmistettu STIGA SpA -yhtiön toimesta ja niitä suojaa tekijänoikeuslaki. – Asiakirjan kaikenlainen kopioiminen tai muuttaminen, osittainkin, on kielletty ilman erityistä lupaa.

FR • Le contenu et les images du présent manuel d'utilisation ont été réalisés pour le compte de STIGA SpA et sont protégés par un droit d'auteur - Toute reproduction ou modification non autorisée, même partielle, du document, est interdite.

HR • Sadržaj i slike u ovom priručniku za uporabu izrađeni su za tvrtku STIGA SpA te su obuhvaćeni autorskim pravima – Zabranjuje se neovlašteno umnožavanje ili prilagodba, djelomična ili u cijelosti, ovog dokumenta.

HU • Ennek a használati útmutatónak a tartalma és a benne szereplő képek kizárólag a STIGA SpA számára készültek és szerzői joggal védettek – tilos a dokumentum bármely részének vagy egészének engedély nélküli sokszorosítása és módosítása.

LT • Šio naudotojo vadovo turinys ir paveikslėliai skirti tik „STIGA SpA“ ir yra saugomi autorių teisėmis – dokumentą atgaminti ar modifikuoti, visiškai arba iš dalies, yra draudžiama.

LV • Šis lietotāja rokasgrāmatas saturs un attēli ir veidoti tikai STIGA SpA un ir aizsargāti ar autortiesībām. Jebkāda dokumenta vai tā daļas prettiesiska kopēšana vai pārveide ir stingri aizliegta.

MK • Содржината и сликите во Упатството за корисникот се подготвени исклучиво за STIGA SpA и се заштитени со авторски права – забрането е секое делумно или целосно неовластено репродуцирање или измена на документот.

NL • De inhoud en de afbeeldingen van deze gebruikshandleiding werden gerealiseerd voor rekening van STIGA SpA en zijn beschermd door het auteursrecht – Elke niet-geautoriseerde reproductie of wijziging, ook gedeeltelijke, van het document is verboden.

NO • Innholdet og bildene i denne brukerveiledningen er utført på oppdrag fra STIGA SpA og er beskyttet ved opphavsrett – Enhver gjengivelse eller endring, selv kun delvis, er forbudt.

PL • Treść oraz ilustracje zawarte w niniejszej instrukcji obsługi powstały na zlecenie spółki STIGA SpA i są chronione prawami autorskimi – Zabrania się wszelkiego kopiowania bądź modyfikowania, także częściowego, niniejszego dokumentu bez uzyskania stosownej zgody.

PT • As imagens e os conteúdos contidos no presente Manual do Utilizador foram expressamente criados para uso exclusivo da STIGA SpA, encontrando-se protegidos por direitos de autor. Qualquer tipo de reprodução ou alteração, parcial ou integral, não autorizadas deste Manual estão expressamente proibidas.

RO • Conținutul și imaginile din manualul de utilizare de față au fost realizate în numele STIGA SpA și sunt protejate de drepturi de autor – Este interzisă orice reproducere sau modificare chiar și parțială neautorizată a documentului.

RU • Тесты и изображения, содержащиеся в настоящем руководстве, были созданы в интересах STIGA SpA и защищены авторскими правами – Любое несанкционированное воспроизведение или изменение документа запрещено.

SK • Obsah a obrázky v tomto návode na používanie boli spracované menom spoločnosti STIGA SpA a sú chránené autorským právom – Reprodukcie či nepovolené pozměňovanie tohto dokumentu, a to aj čiastočne, je zakázané.



SL • Vsebine in slike v tem uporabniškem priručniku so izdelane za podjetje STIGA SpA in so zaščitene z avtorskimi pravicami – vsakršno nepooblaščenno razmnoževanje ali spreminjanje dokumenta, v celoti ali delno, je prepovedano.

SR • Sadržaj i slike ovog priručnika za upotrebu su napravljeni u ime STIGA SpA i zaštićeni su autorskim pravima – Zabranjena je svaka potpuna ili delimična reprodukcija ili izmena dokumenta bez odobrenja.

SV • Innehållet och bilderna i denna användarhandbok har framställts för STIGA SpA och skyddas av upphovsrätt – all form av reproduktion eller ändring, även partiell, som inte auktoriserats är förbjuden.

TR • Bu Kullanıcı Kilavuzundaki içerik ve resimler açığıca STIGA SpA için üretilmiştir ve telif hakkı ile korunmaktadır – dokümanın izinsiz olarak tamamen ya da kısmen herhangi bir şekilde çoğaltılması ya da değiştirilmesi yasaktır.



.....	
Type:	 LWA dB
..... -s/n -Art.N	
	

STIGA SpA
Via del Lavoro, 6
31033 Castelfranco Veneto (TV) ITALY