

# STIGA®

Park series 4WD / 2WD

420

420 P

520 P

540 PX

720 W

720 PW

740 PWX

Type P 901 CH



TOSAERBA CON CONDUCENTE A BORDO SEDUTO

SEKAČKA SE SEDÍCÍ OBSLUHOU

HAVETRAKTOR/HAVETRAKTOR MED FRONTKLIPPER (FM)

AUFSITZMÄHER (RASENMÄHER MIT FAHRERSITZ MIT SITZENDEM BENUTZER)

RIDE-ON LAWNMOWER WITH SEATED OPERATOR

CORTADORA DE PASTO CON CONDUCTOR SENTADO

ISTUVA JUHIGA MURUNIITJA

PÄÄLTÄAJETTAVA RUOHONLEIKKURI

TONDEUSE À GAZON À CONDUCTEUR ASSIS

SJEDEĆA KOSILICA TRAVE S OPERATEROM

VEZETŐÜLÉSES FŰNYÍRÓGÉP

BALNINĚ VEJAPJOVÉ SU SĚDINČIU OPERATORIUMI

SĚŽOT VADÁMA ZÁLIENU PĽAUJMAŠINA

GRASMAAIER MET ZITTENDE BEDIENER

SITTEGRESSKLIPPER

KOSIARKA Z OPERATOREM JADĄCYM, W POZYCJI SIEDZĄCEJ NA MASZYNIE

CORTA-RELVAS PARA OPERADOR SENTADO

ЕЗДОВАЯ КОСИЛКА С СИДЕНЬЕМ

TRAKTORSKA KOSILNICA

ÅKGRÄSKLIPPARE OCH FRÄMRE KLIPPNING (FM)

MANUALE DI ISTRUZIONI .....IT

INSTRUKTIONSMANUAL .....CS

INSTRUKTIONSMANUAL .....DA

GEBRAUCHSANWEISUNG .....DE

INSTRUCTION MANUAL .....EN

USO Y MANTENIMIENTO .....ES

KASUTUSJUHEND .....ET

KÄYTTÖOPAS .....FI

MANUEL D'UTILISATION .....FR

PRIRUČNIK ZA UPORABU .....HR

HASZNÁLATI UTASÍTÁS .....HU

VARTOJIMO INSTRUKCIJA .....LT

OPERATORA ROKASGRĀMATA .....LV

GEBRUIKERSHANDLEIDINGNL .....NL

BRUKSANVISNING - VEDLIKEHOLD .....NO

INSTRUKCJE OBSŁUGI .....PL

MANUAL DE USO .....PT

РУКОВОДСТВО ПО ЭКСПЛУАТАЦИИ .....RU

PRIROČNIK Z NAVODILI .....SL

BRUKSANVISNING OCH UNDERHÅLL .....SV



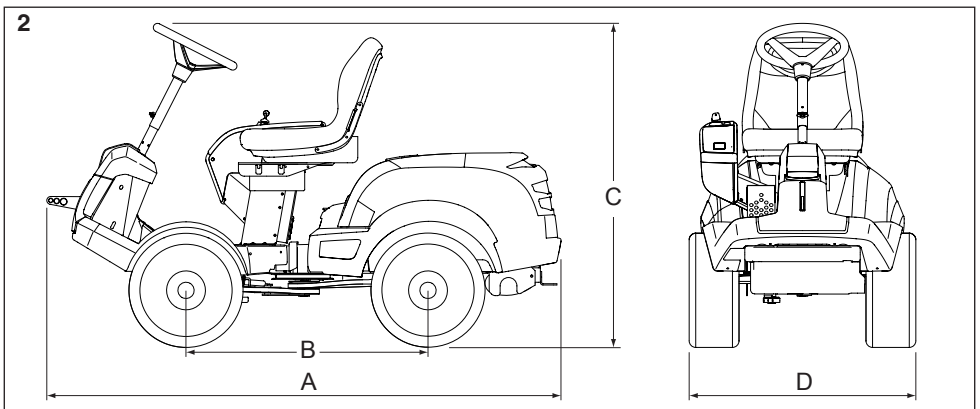
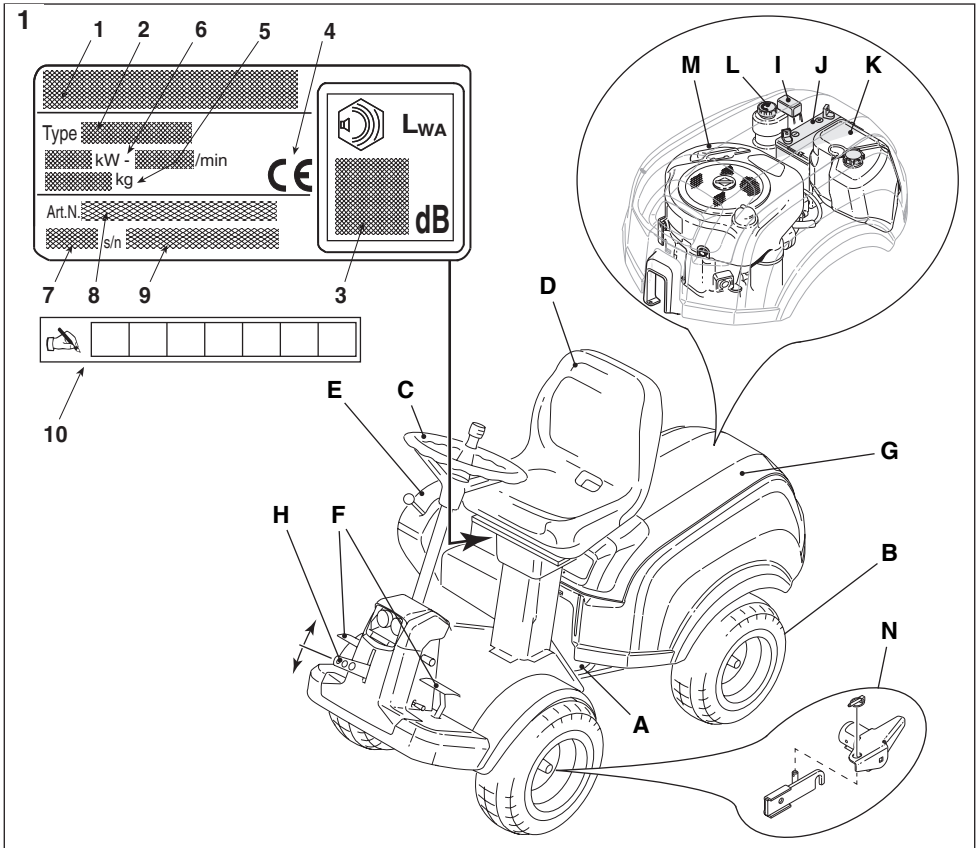

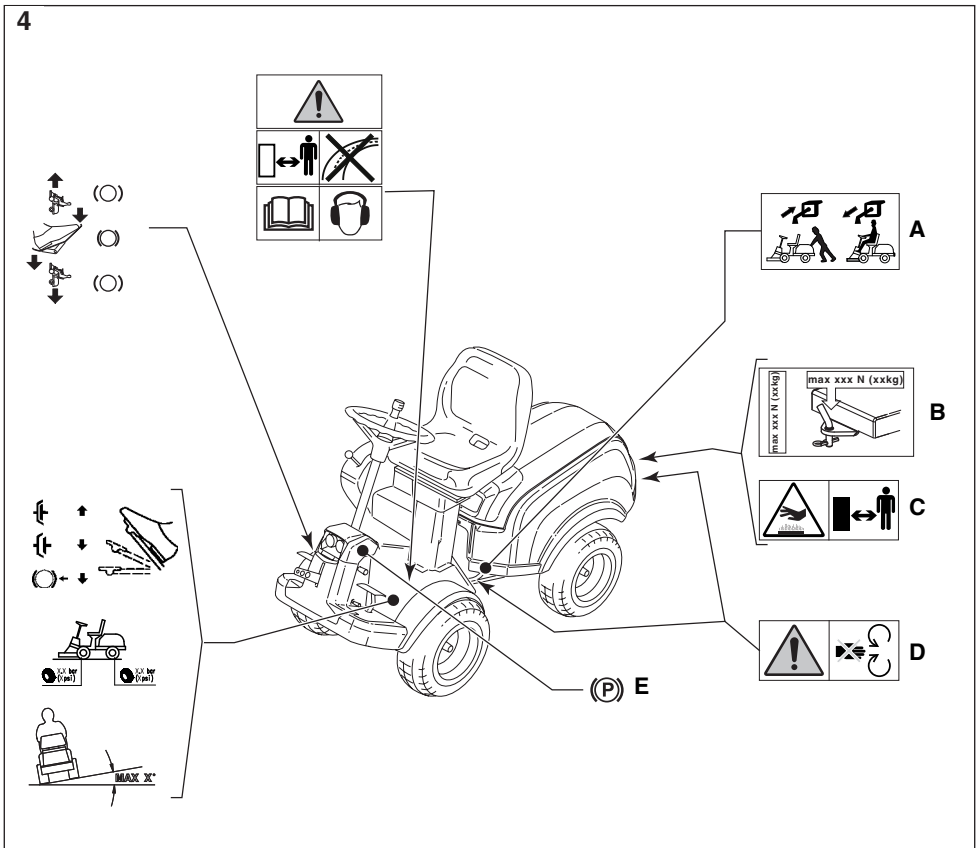
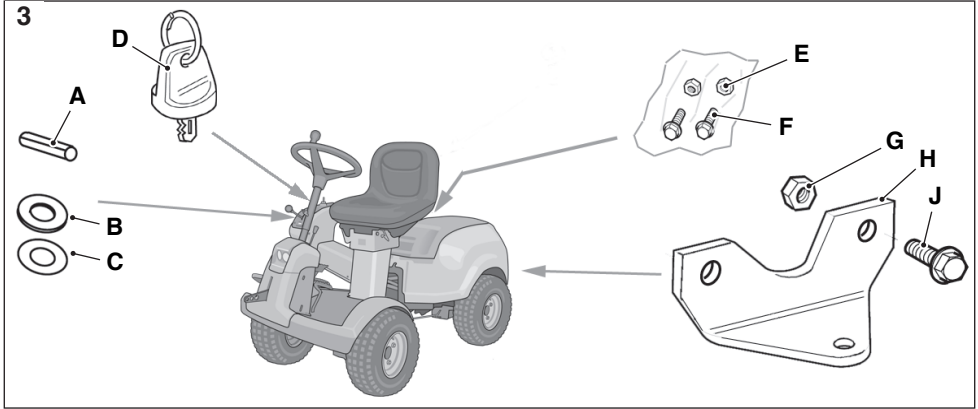

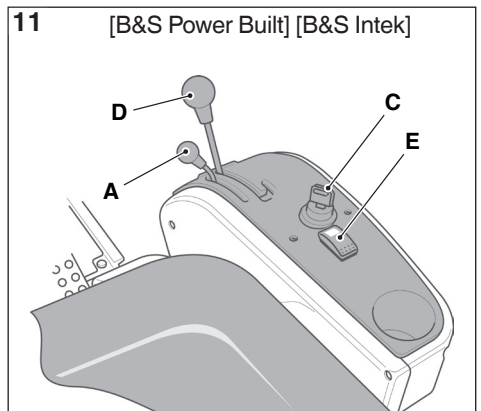
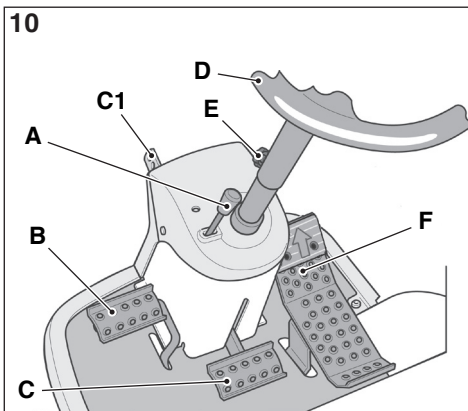
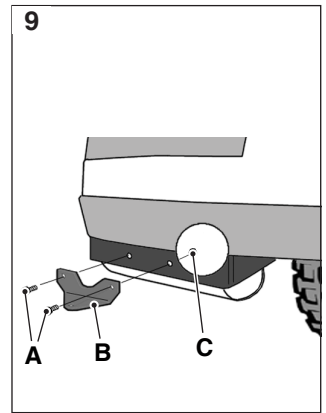
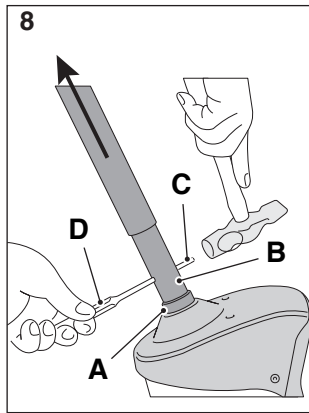
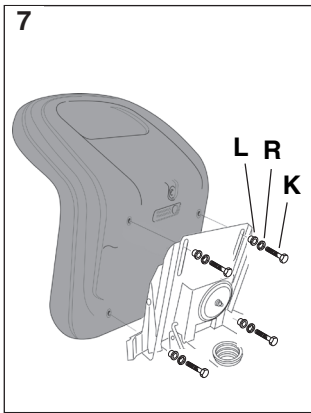
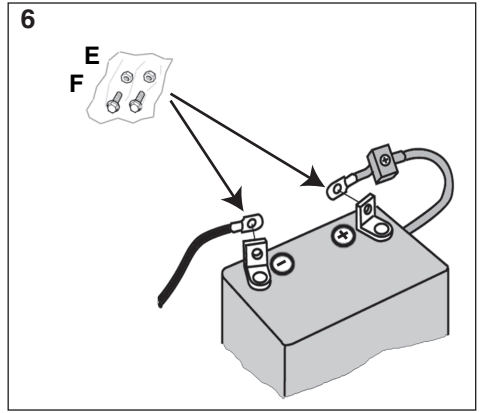
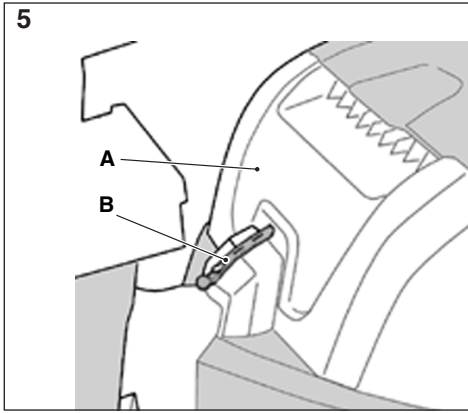

12

[B&S Vanguard]

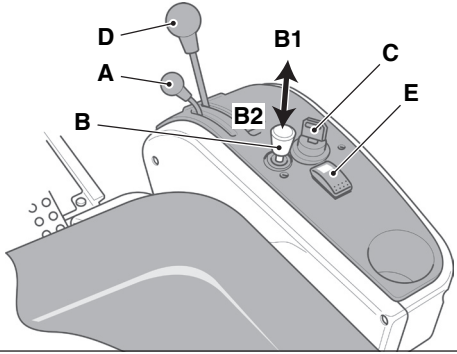

13

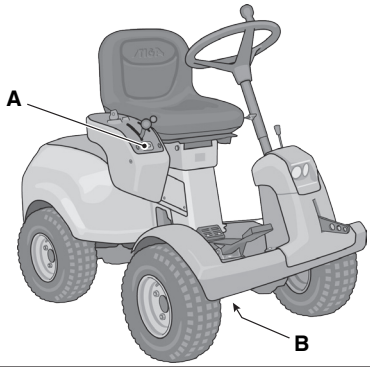

14

2WD

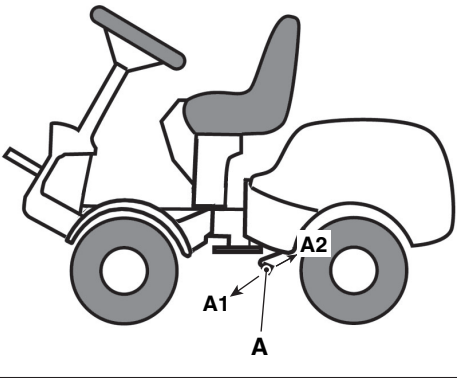

15

4WD

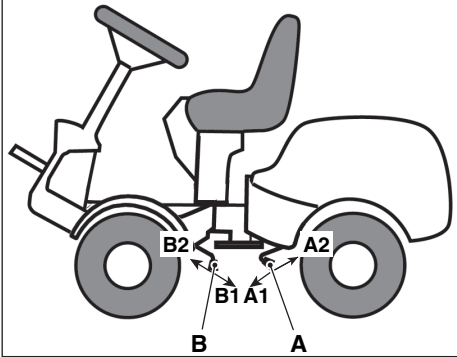

16

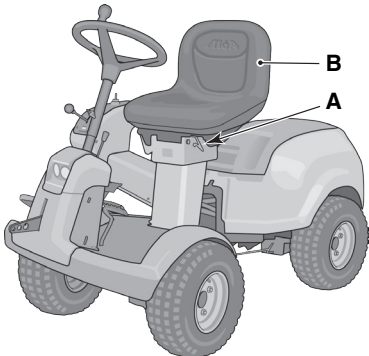

17

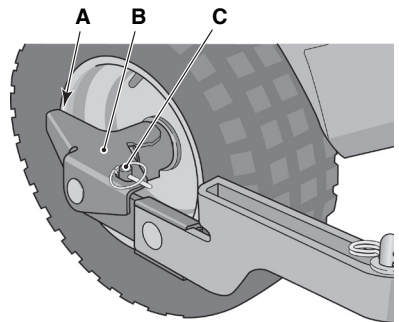

18

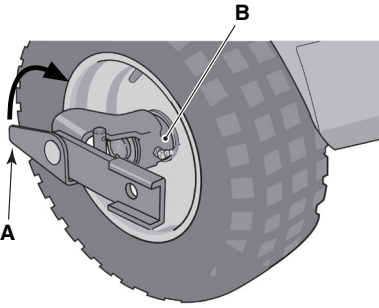

19

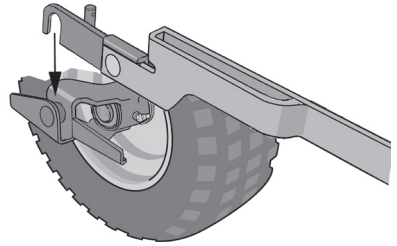

20

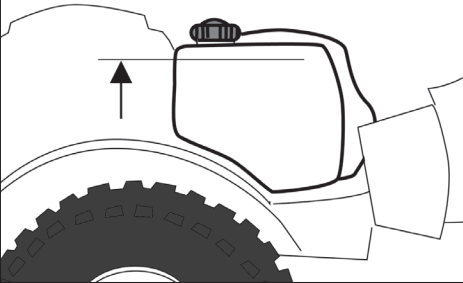

21

[B&S Power Built] [B&S Intek]

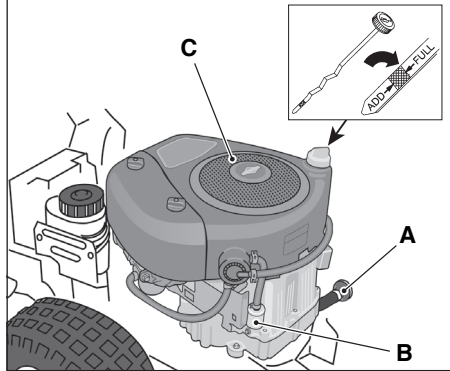

22

[B&S Vanguard]

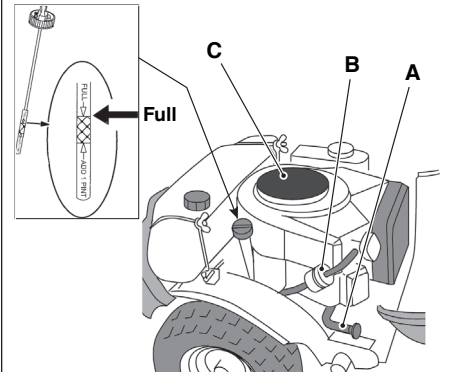

23

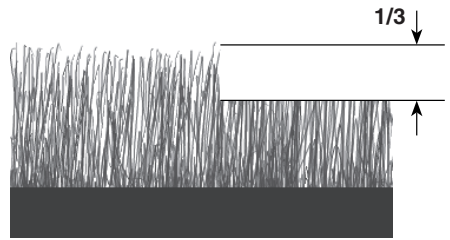

24

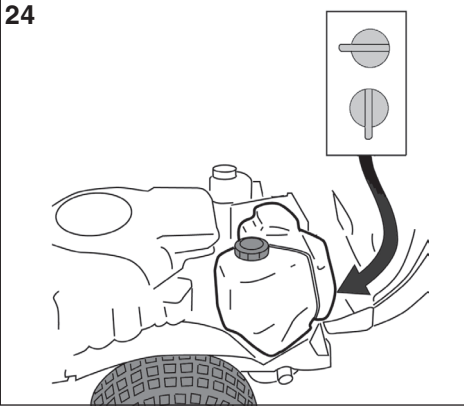

25

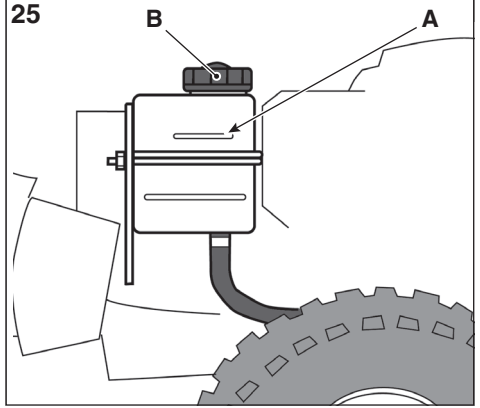

26

4WD

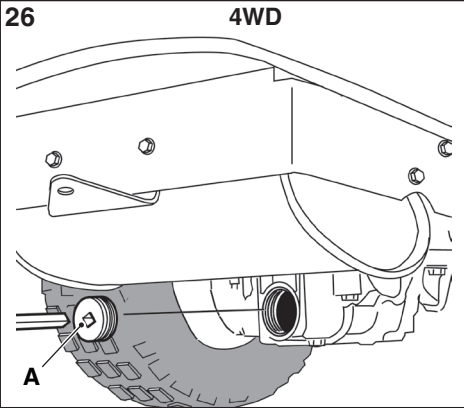

27

2WD

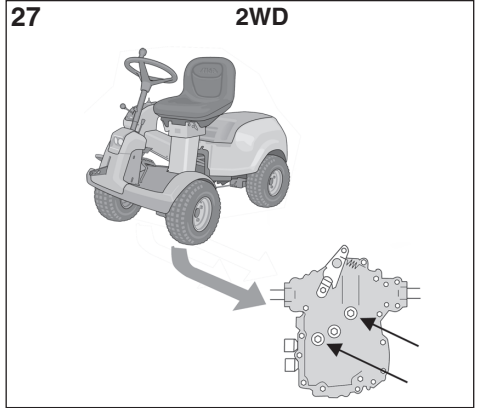

28

4WD

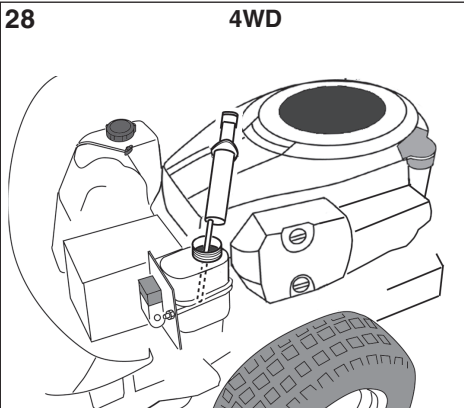

29

4WD

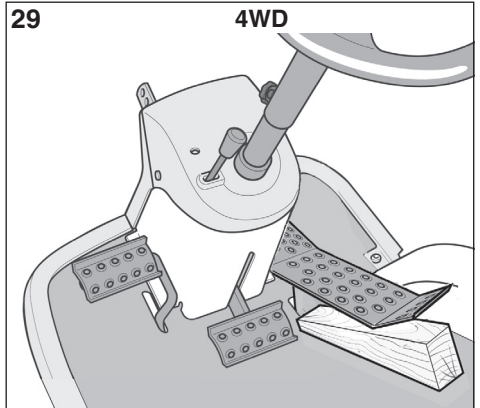



30

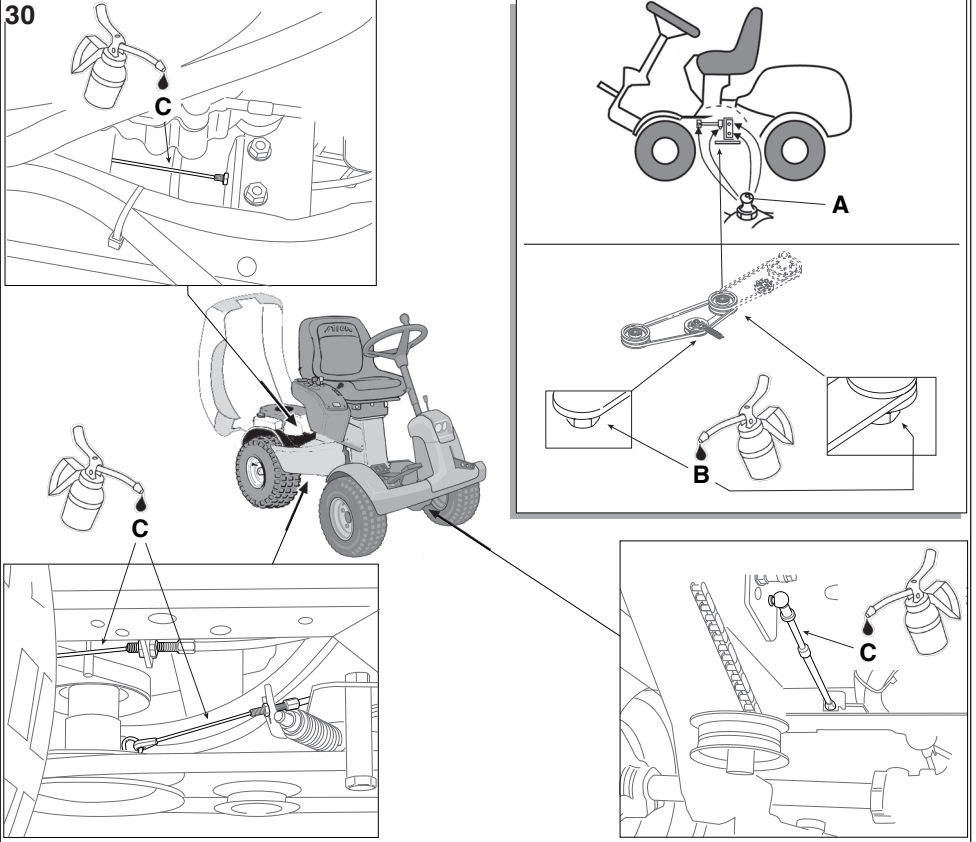

31

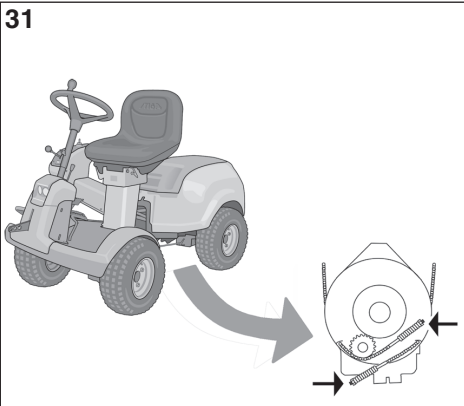

32

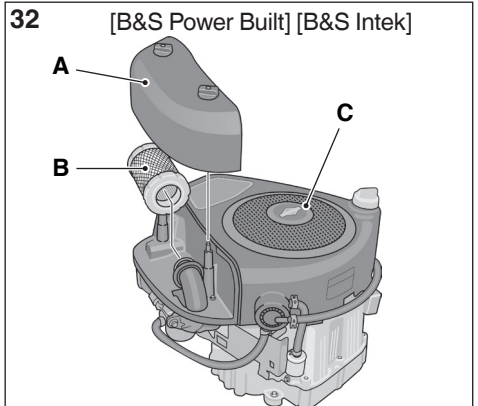

**33**

[B&S Vanguard]

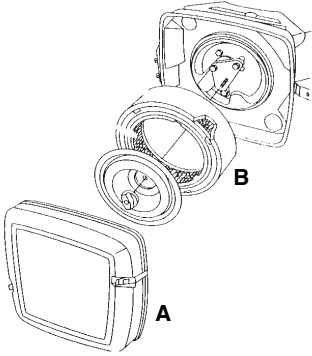

**34**

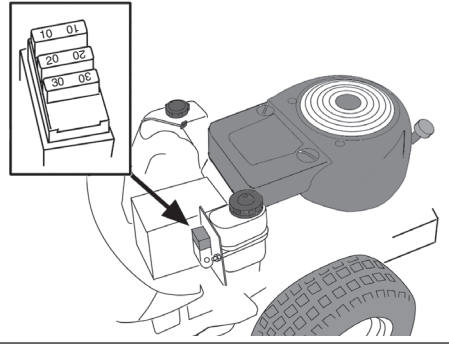

## 0 TABELLA DATI TECNICI

[1]	Type		P 901 CH	P 901 CH	P 901 CH
[2]	Modello		PARK - 420	PARK - 420 P	PARK - 520 P
[3]	Motore		B&S Power Built 3130 AVS (21R807) [A] (con pompa benzina)	B&S Intek 4155 AVS (31R577) [A] (con pompa benzina)	B&S Intek 4185 (31R877)
[4]	Cilindrata	cc	344	500	500
[5]	Trazione		2WD	2WD	2WD
[6]	Potenza	kW	7,4	8,82	10,72
[7]	Giri motore	rpm	3200	3200	3200
[8]	Impianto elettrico		12 V	12 V	12 V
[9]	Batteria		VLRA	VRLA	VLRA
[10]	Carburante		[A] Benzina senza piombo	[A] Benzina senza piombo	[A] Benzina senza piombo
[11]	Capacità serbatoio carburante	l	12	12	12
[12]	Olio motore		SAE 10W-30	SAE 10W-30	SAE 10W-30
[13]	Olio motore, classe di servizio		[A] SJ o superiore	[A] SJ o superiore	[A] SJ o superiore
[14]	Capacità serbatoio olio motore, senza sostituzione del filtro	l	1,4	1,4	1,4
[15]	Capacità serbatoio olio motore, con sostituzione del filtro	l	/	1,5	1,5
[16]	Olio Trasmissione		/	/	/
[17]	Quantità olio trasmissione al mo- mento del cambio	l	/	/	/
[18]	Candela		[A] Champion XC12YC o equivalente.	[A] Champion XC12YC o equivalente.	[A] Champion XC12YC o equivalente.
[19]	Candela, distanza elettrodi	mm	0,75	0,75	0,75
[20]	Pneumatici	dim.	16x7.50-8	16x7.50-8	16x7.50-8
[21]	Pressione pneumatici	anteriore	bar 0,6 - psi 9	bar 0,6 - psi 9	bar 0,6 - psi 9
		posteriore	bar 0,4 - psi 6	bar 0,4 - psi 6	bar 0,4 - psi 6
[22]	Altezza di taglio	mm	[A] Per l'altezza di taglio, vedere la "Tabella Dati Tecnici" del manuale "assieme del dispositivo di taglio"		
[23]	Velocità di avanzamento (indicati- va), in marcia avanti	km/h	10	10	10
[24]	Velocità di avanzamento (indicati- va), in retromarcia	km/h	6	6	6
[25]	Massa	kg	180+230		
[26]	A = Lunghezza	mm	1960	1960	1960
[27]	B = Passo	mm	992,5	992,5	992,5
[28]	C = Altezza	mm	1236	1236	1236
[29]	D = Larghezza	mm	864	864	864
[30]	Livello di potenza sonora misurato	dB(A)	98,5	98,5	98,5
[31]	Incertezza	dB(A)	0,85	0,85	0,85
[32]	Livello di potenza sonora garantito	dB(A)	100	100	100
[33]	Livello di pressione sonora	dB(A)	83	84	84
[34]	Incertezza	dB(A)	0,7	0,7	0,7
[35]	Valore delle vibrazioni al posto di guida	m/s <sup>2</sup>	< 0,9	< 0,9	< 0,9
[36]	Incertezza	m/s <sup>2</sup>	0,3	0,3	0,3
[37]	Valore delle vibrazioni al volante	m/s <sup>2</sup>	< 2,5	< 2,5	< 2,5
[38]	Incertezza	m/s <sup>2</sup>	0,3	0,3	0,3

## 0 TABELLA DATI TECNICI















[1] Type		P 901 CH	P 901 CH	P 901 CH
[2] Modello		PARK - 540 PX	PARK - 720 W / 720 PW	PARK - 740 PWX
[3] Motore		B&S Intek 4185 (31R877)	B&S Vanguard 18hp 2 cyl (356777)	B&S Vanguard 18hp 2 cyl (356777)
[4] Cilindrata	cc	500	570	570
[5] Trazione		4WD	2WD	4WD
[6] Potenza	kW	10,72	11,82	11,82
[7] Giri motore	rpm	3200	3200	3200
[8] Impianto elettrico		12V	12V	12V
[9] Batteria		VLRA	VLRA	VLRA
[10] Carburante		[A] Benzina senza piombo	[A] Benzina senza piombo	[A] Benzina senza piombo
[11] Capacità serbatoio carburante	l	12	12	12
[12] Olio motore		SAE 10W-30	SAE 10W-30	SAE 10W-30
[13] Olio motore, classe di servizio		[A] SJ o superiore	[A] SJ o superiore	[A] SJ o superiore
[14] Capacità serbatoio olio motore, senza sostituzione del filtro	l	1,4	1,6	1,6
[15] Capacità serbatoio olio motore, con sostituzione del filtro	l	1,5	1,7	1,7
[16] Olio Trasmissione		5W-40 / 5W-50	5W-40 / 5W-50	5W-40 / 5W-50
[17] Quantità olio trasmissione al momento del cambio	l	3,6	3,6	3,6
[18] Candela		[A] Champion XC12YC o equivalente.	[A] Champion XC12YC o equivalente.	[A] Champion XC12YC o equivalente.
[19] Candela, distanza elettrodi	mm	0,75	0,75	0,75
[20] Pneumatici	dim.	16x7.50-8	16x7.50-8	16x7.50-8
[21] Pressione pneumatici	anteriore	bar 0,6 - psi 9	bar 0,6 - psi 9	bar 0,6 - psi 9
	posteriore	bar 0,4 - psi 6	bar 0,4 - psi 6	bar 0,4 - psi 6
[22] Altezza di taglio	mm	[A] Per l'altezza di taglio, vedere la "Tabella Dati Tecnici" del manuale "assieme del dispositivo di taglio"		
[23] Velocità di avanzamento (indicativa), in marcia avanti	km/h	10	10	10
[24] Velocità di avanzamento (indicativa), in retromarcia	km/h	6	6	6
[25] Massa	kg	180÷230		
[26] A = Lunghezza	mm	1960	1960	1960
[27] B = Passo	mm	992,5	992,5	992,5
[28] C = Altezza	mm	1236	1236	1236
[29] D = Larghezza	mm	864	864	864
[30] Livello di potenza sonora misurato	dB(A)	98,5	98,5	98,5
[31] Incertezza	dB(A)	0,85	0,85	0,85
[32] Livello di potenza sonora garantito	dB(A)	100	100	100
[33] Livello di pressione sonora	dB(A)	84	84	84
[34] Incertezza	dB(A)	0,7	0,7	0,7
[35] Valore delle vibrazioni al posto di guida	m/s <sup>2</sup>	< 0,9	< 0,9	< 0,9
[36] Incertezza	m/s <sup>2</sup>	0,3	0,3	0,3
[37] Valore delle vibrazioni al volante	m/s <sup>2</sup>	< 2,5	< 2,5	< 2,5
[38] Incertezza	m/s <sup>2</sup>	0,3	0,3	0,3

## 0 TABELLA DATI TECNICI

[39]	ACCESSORI A RICHIESTA	
[40]	Descrizione	Type
[41]	Rimorchio	45-03453-997 / ST-1405
[42]	Fertilizzatore	45-03153-997
[43]	Raccogli foglie e erba	45-03313-997 (**) 45-02616-997 (**)
[44]	Rastrello	ST-1407 / ST-1408
[45]	Catene da neve	√
[46]	Ruote da fango / neve	√
[47]	Assieme del dispositivo di taglio	95CP / 95CP E
		100C E
		105C E
		110C E
		110C E QF(**) 125C E QF(**)
[48]	Erpice frontale	PA304 (**)
[49]	Trinciatrice	PA409 / PA409 E (**)
[50]	Spazzaneve a turbina	PA407 (**)
[51]	Spazzatrice frontale	PA501 / PVA101 / FKM 900 KA
[52]	Spalaneve a lama	ST-1404
[53]	Arieggiatore/scarificatore	LAR 1405 / LAR 1405 E
[54]	Contrappesi ruote posteriori	√
[55]	Sollevatore posteriore per accessori	ST-1406
[56]	 <b>(**) Per i modelli 2WD, è obbligatorio installare i contrappesi sulle ruote posteriori.</b>	

## 0 TABELLA DATI TECNICI

[57] TABELLA PER LA CORRETTA COMBINAZIONE DEGLI ACCESSORI

		[58] ACCESSORI POSTERIORI				
Accessorio [60]	 [41]	 [42]	 [43]	 [44]	 [45]	 [46]
 [45]	√	√	-	-	-	-
 [47]	√ (***)	√	√	√	-	√
 [48]	√	-	-	√	-	-
 [49]	-	-	√	-	-	√
 [50]	-	√	-	-	√	√
 [51]	-	√	-	-	√	√
 [52]	-	√	-	-	√	√
 [53]	-	-	√	-	-	-

[59] ACCESSORI FRONTALI

[61]  (\*\*\*) Per i modelli 2WD, con l'applicazione contemporanea dell'insieme dei dispositivi di taglio "type 110C E, 110C E QF, 125C E QF" e del rimorchio è obbligatorio installare i contrappesi sulle ruote posteriori.

## 0 TABULKA TECHNICKÝCH ÚDAJŮ

[1]	Typ	[42]	Rozmetadlo hnojiv
[2]	Model	[43]	Sběrač listů a trávy
[3]	Motor	[44]	Pohrabovač
[4]	Objem motoru	[45]	Sněhové řetězy
[5]	Trakce	[46]	Kola do bláta / sněhu
[6]	Výkon	[47]	Sekací jednotka
[7]	Otáčky motoru	[48]	Přední brána
[8]	Elektrický systém	[49]	Řezačka
[9]	Akumulátor	[50]	Turbinová sněhová fréza
[10]	Palivo	[51]	Přední zametací zařízení
[A]	Bezolovnatý benzín	[52]	Sněhová radlice
[11]	Kapacita palivové nádrže	[53]	Provdzušňovač/rozrývač
[12]	Motorový olej	[54]	Protizávaží na zadních kolech
[13]	Motorový olej, provozní třída	[55]	Zadní zdvih pro příslušenství
[A]	SJ nebo vyšší	[56]	(**) U modelů 2WD, je povinné nainstalovat protizávaží na zadních kolech.
[14]	Kapacita olejové nádrže, bez výměny filtru	[57]	TABULKA PRO SPRÁVNOU KOMBINACI PŘÍSLUŠENSTVÍ
[15]	Kapacita olejové nádrže, bez výměny filtru	[58]	ZADNÍ PŘÍSLUŠENSTVÍ
[16]	Převodový olej	[59]	PŘEDNÍ PŘÍSLUŠENSTVÍ
[17]	Množství převodového oleje v momentě převodu	[60]	Příslušenství
[18]	Svíčka	[61]	(***) U modelů 2WD, při současném použití sekacích zařízení "typu 110C E, 110C E QF, 125C E QF" a přípojného vozidla, je povinné nainstalovat protizávaží na zadních kolech.
[A]	Champion XC12YC nebo ekvivalentní typ		
[19]	Svíčka, vzdálenost elektrod		
[20]	Pneumatiky		
[21]	Plak v pneumatikách	přední pneumatikách zadní pneumatiky	
[22]	Výška sekání		
[A]	Informace o výšce sekání naleznete v části "Tabulka technických údajů" manuálu "jednotky sekací jednotky"		
[23]	Rychlost postupu (indikativní) při postupu napřed		
[24]	Rychlost postupu (indikativní) při couvání		
[25]	Hmotnost		
[26]	A = Délka		
[27]	B = Krok		
[28]	C = Výška		
[29]	D = Šířka		
[30]	Naměřená hladina akustického výkonu		
[31]	Nejistá		
[32]	Garantovaná hladina akustického výkonu		
[33]	Hladina akustického tlaku		
[34]	Nejistá		
[35]	Hodnota vibrací na místě řidiče		
[36]	Nejistá		
[37]	Hodnota vibrací u volantu		
[38]	Nejistá		
[39]	PŘÍSLUŠENSTVÍ NA POŽÁDÁNÍ		
[40]	Popis		
[41]	Přívěs		

## 0 TABEL OVER TEKNISKE SPECIFIKATIONER

[1]	Type	[41]	Anhænger
[2]	Model	[42]	Gødningsspreder
[3]	Motor	[43]	Blad- og græsindsamler
[4]	Cylindervolumen	[44]	Rive
[5]	Antrieb	[45]	Snekæder
[6]	Effekt	[46]	Mudder- og snehjul
[7]	Motoromdrejninger	[47]	Klippeaggregat
[8]	Elektrisk anlæg	[48]	Frontharve
[9]	Batteri	[49]	Skæremaskine
[10]	Brændstof	[50]	Turbineudstyret sneplov
[A]	Blyfri benzin	[51]	Frontmonteret fejmaskine
[11]	Brændstoftankens rumfang	[52]	Sneplov med klinge
[12]	Motorolie	[53]	Udluftningsgreb/plænelufter
[13]	Motorolie, klassificering	[54]	Baghjulenes kontravægte
[A]	SJ eller højere	[55]	Udstyrsløfteaggregat bagpå
[14]	Motorolietankkapacitet, uden filterudskiftning	[56]	(**) Bei den Modellen 2WD ist die Installation der Hinterradgewichte vorgeschrieben.
[15]	Motorolietankkapacitet, med filterudskiftning	[57]	TABEL OVER Udstyrets KORREKTE KOMBINATION
[16]	Transmissionsolie	[58]	BAGMONTERET TILBEHØR
[17]	Transmissionsolie mængde på udskiftningstidspunktet	[59]	FORMONTERET TILBEHØR
[18]	Tændrør	[60]	Tilbehør
[A]	Champion XC12YC eller gleichwertig	[61]	(***) Bei den Modellen 2WD ist mit gleichzeitigem Einsatz der Baugruppe Schneidvorrichtungen "Typ 110C E, 110C E QF, 125C E QF" und des Anhängers die Installation der Hinterradgewichte vorgeschrieben.
[19]	Tændrør, elektrodeafstand		
[20]	Dæk		
[21]	Dæktryk		forhjul baghjul
[22]	Schnitthöhe		
[A]	Indhent oplysninger om klippehøjden i "Tabel over tekniske specifikationer" i vejledningen "klippeaggregat"		
[23]	Fremføringshastighed (vejledende), i fremgear		
[24]	Fremføringshastighed (vejledende), i bakgear		
[25]	Vægt		
[26]	A = Længde		
[27]	B = Akselafstand		
[28]	C = Højde		
[29]	D = Bredde		
[30]	Målt lydeffektniveau		
[31]	Usikkerhed		
[32]	Garanteret lydeffektniveau		
[33]	Lydtrykniveau		
[34]	Usikkerhed		
[35]	Vibrationsværdi ved førerpladsen		
[36]	Usikkerhed		
[37]	Vibrationsværdi ved rattet		
[38]	Usikkerhed		
[39]	EKSTRAUDSTYR		
[40]	Beskrivelse		



## 0 ÜBERSICHT DER TECHNISCHEN DATEN

[1]	Typ	[42]	Dungstreuer
[2]	Modell	[43]	Laub- und Grassammler
[3]	Motor	[44]	Harken
[4]	Hubraum	[45]	Schneeketten
[5]	Antrieb	[46]	M+S-Räder (Matsch- und Schneeräder)
[6]	Leistung	[47]	Baugruppe Mähwerk
[7]	Motordrehzahl	[48]	Frontegge
[8]	Elektrische Anlage	[49]	Häcksler
[9]	Batterie	[50]	Schneefräse
[10]	Kraftstoff	[51]	Kehrvorsatz
[A]	Bleifreies Benzin	[52]	Schneepflug
[11]	Kraftstofftankinhalt	[53]	Vertikutierer/Lockerer
[12]	Motoröl	[54]	Hinterradgewichte
[13]	Motoröl, Betriebsklasse	[55]	Heckseitiger Geräteheber
[A]	SJ oder höher	[56]	(**) Bei den Modellen 2WD ist die Installation der Hinterradgewichte vorgeschrieben.
[14]	Inhalt Motorölbehälter, ohne Filteraustausch	[57]	ÜBERSICHT FÜR DIE KORREKTE ZUBEHÖR-KOMBINATION
[15]	Inhalt Motorölbehälter, mit Filteraustausch	[58]	HECKSEITIGES ZUBEHÖR
[16]	Getriebeöl	[59]	FRONTSEITIGES ZUBEHÖR
[17]	Getriebeölmenge beim Wechsel	[60]	Zubehör
[18]	Zündkerze	[61]	(***) Bei den Modellen 2WD ist mit gleichzeitigem Einsatz der Baugruppe Schneidvorrichtungen "Typ 110C E, 110C E QF, 125C E QF" und des Anhängers die Installation der Hinterradgewichte vorgeschrieben.
[A]	Champion XC12YC oder gleichwertig		
[19]	Zündkerze, Elektrodenabstand		
[20]	Reifung		
[21]	Reifendruck		
		vorn	
		hinten	
[22]	Schnitthöhe		
[A]	Für die Schnitthöhe siehe "Übersicht der technischen Daten" in der Anleitung "Baugruppe Mähwerk"		
[23]	Fahrgeschwindigkeit (ca.), vorwärts		
[24]	Fahrgeschwindigkeit (ca.), rückwärts		
[25]	Gewicht		
[26]	A = Länge		
[27]	B = Radstand		
[28]	C = Höhe		
[29]	D = Breite		
[30]	Gemessener Schalleistungspegel		
[31]	Messunsicherheit		
[32]	Garantierter Schalleistungspegel		
[33]	Schalldruckpegel		
[34]	Messunsicherheit		
[35]	Vibrationen am Fahrersitz		
[36]	Messunsicherheit		
[37]	Vibrationen am Lenkrad		
[38]	Messunsicherheit		
[39]	SONDERZUBEHÖR		
[40]	Beschreibung:		
[41]	Anhänger		

## 0 TECHNICAL DATA TABLE

[1]	Type	[42]	Fertilizer spreader
[2]	Model	[43]	Grass and leaf collector
[3]	Engine	[44]	Rake
[4]	Engine displacement	[45]	Snow chains
[5]	Traction	[46]	Mud / Snow wheels
[6]	Power	[47]	Cutting device assy
[7]	Engine revs	[48]	Front harrow
[8]	Electrical System	[49]	"Shredder
[9]	Battery	[50]	Snow thrower
[10]	Fuel	[51]	Front sweeper
[A]	Unleaded petrol	[52]	Blade type snow plough
[11]	Fuel tank capacity	[53]	Aerator/scarifier
[12]	Engine oil	[54]	Rear wheel counterweights
[13]	Engine oil, service category	[55]	Rear lifting assembly for accessories
[A]	SJ or higher	[56]	(**) For 2WD models, counterweights must be installed on the rear wheels.
[14]	Engine oil tank capacity, without filter change	[57]	TABLE FOR CORRECT ACCESSORY COMBINATIONS
[15]	Engine oil tank capacity, with filter change	[58]	REAR ACCESSORIES
[16]	Transmission fluid	[59]	FRONT ACCESSORIES
[17]	Quantity of transmission fluid required for fluid change	[60]	Accessory
[18]	Spark plug	[61]	(***) For 2WD models, when the cutting device assies (type 110C E, 110C E QF, 125C E QF) are installed at the same time as the trailer, counterweights must be installed on the rear wheels.
[A]	Champion XC12YC or equivalent		
[19]	Spark gap		
[20]	Tyres		
[21]	Tyre pressure	front	
		rear	
[22]	Cutting height		
[A]	For the cutting height, please refer to the "Technical Data Table" in the cutting device assy manual.		
[23]	Forward travel speed (indicative)		
[24]	Reverse travel speed (indicative)		
[25]	Weight		
[26]	A = Length		
[27]	B = Pitch		
[28]	C = Height		
[29]	D = Width		
[30]	Measured sound power level		
[31]	Uncertainty		
[32]	Guaranteed sound power level		
[33]	Sound pressure level		
[34]	Uncertainty		
[35]	Vibration value in the driver's seat		
[36]	Uncertainty		
[37]	Vibration value in the steering wheel		
[38]	Uncertainty		
[39]	ACCESSORIES AVAILABLE ON REQUEST		
[40]	Description		
[41]	Trailer		

## 0 TABLA DE DATOS TÉCNICOS

[1]	Tipo	[39]	ACCESORIOS BAJO PEDIDO
[2]	Modelo	[40]	Descripción
[3]	Motor	[41]	Remolque
[4]	Cilindrada	[42]	Fertilizador
[5]	Tracción	[43]	Recoge hojas e hierba
[6]	Potencia	[44]	Rastrillo
[7]	Revoluciones del motor	[45]	Cadenas para nieve
[8]	Sistema eléctrico	[46]	Ruedas para fango y nieve
[9]	Batería	[47]	Grupo del dispositivo de corte
[10]	Carburante	[48]	Arado frontal
[A]	Gasolina sin plomo	[49]	Trituradora
[11]	Capacidad del depósito de carburante	[50]	Quitanieves
[12]	Aceite motor	[51]	Quitanieves frontal
[13]	Aceite motor, tipo de servicio	[52]	Quitanieves de cuchilla
[A]	SJ o superior	[53]	Aireador/escarificador
[14]	Capacidad del depósito de aceite del motor, sin cambio de filtro	[54]	Contrapesos ruedas traseras
[15]	Capacidad del depósito de aceite del motor, con cambio de filtro	[55]	Elevador trasero para accesorios
[16]	Aceite de transmisión	[56]	(**) En los modelos 2WD, es obligatorio instalar los contrapesos en las ruedas traseras.
[17]	Cantidad de aceite de transmisión al efectuar el cambio	[57]	TABLA PARA COMBINAR ACCESORIOS
[18]	Bujía	[58]	ACCESORIOS TRASEROS
[A]	Champion XC12YC o equivalente	[59]	ACCESORIOS FRONTALES
[19]	Bujía, distancia electrodos	[60]	Accesorio
[20]	Neumáticos	[61]	(***) En los modelos 2WD, cuando el grupo de dispositivos de corte "type 110C E, 110C E QF, 125C E QF" y el remolque se aplican contemporáneamente, es obligatorio instalar los contrapesos en las ruedas traseras.
[21]	Presión de neumáticos		delantera
			trasera
[22]	Altura de corte		
[A]	Para más información sobre la altura de corte, consulte la "Tabla de Datos Técnicos" del manual "grupo del dispositivo de corte"		
[23]	Velocidad de avance (indicativa) con marcha adelante		
[24]	Velocidad de avance (indicativa) con marcha atrás		
[25]	Peso		
[26]	A = Longitud		
[27]	B = Paso		
[28]	C = Altura		
[29]	D = Anchura		
[30]	Nivel de potencia sonora medido		
[31]	Incertidumbre		
[32]	Nivel de potencia sonora garantizado		
[33]	Nivel de presión sonora		
[34]	Incertidumbre		
[35]	Valor de las vibraciones en el puesto de conducción		
[36]	Incertidumbre		
[37]	Valor de vibraciones en el volante		
[38]	Incertidumbre		

## 0 TEHNILISTE ANDMETE TABEL

[1]	Tüüp	[43]	Lehtede ja rohu koguja
[2]	Mudel	[44]	Reha
[3]	Mootor	[45]	Lumeketid
[4]	Silindrid	[46]	Lume- ja mudarattad
[5]	Vedu	[47]	Niitmisseade
[6]	Võimsus	[48]	Esiäke
[7]	Mootori pöörete arv	[49]	Purustaja
[8]	Elektriseade	[50]	Turbiiniga lumepühkija
[9]	Aku	[51]	Eesmine koristusseade
[10]	Kütus	[52]	Lumesahk
[A]	Pliivaba bensiin	[53]	Kobestaja
[11]	Kütusepaagi maht	[54]	Tagumiste rataste vastukaalud
[12]	Mootoriõli	[55]	Tagumine tõstuk tarvikute jaoks
[13]	Mootoriõli, teenindusklass	[56]	(**) 2WD mudelitel on kohustuslik paigaldada tagaratastele vastukaalud
[A]	SJ ja parem	[57]	TARVIKUTE ÕIGE KOMBINEERIMISE TABEL
[14]	Mootoriõli paagi maht, ilma filtri asendusega	[58]	TAGUMISED TARVIKUD
[15]	Mootoriõli paagi maht, koos filtri asendusega	[59]	EESMISED TARVIKUD
[16]	Ülekandeõli	[60]	Tarvik
[17]	Ülekandeõli maht vahetamise ajal	[61]	(**) 2WD mudelitel "110C E, 110C E QF, 125C E QF tüüpi" niitmisseadme ja treileri samaaegsel kasutamisel on kohustuslik paigaldada tagaratastele vastukaalud
[18]	Küünal		
[A]	Champion XC12YC või samaväärne		
[19]	Küünal, elektroodide vahemaa		
[20]	Rehvid		
[21]	Rehvirõhk		ees taga
[22]	Niitmiskõrgus		
[A]	Niitmiskõrgust vaata niitmisseadme juhendis tabelist "Tehnilised andmed"		
[23]	Liikumiskiirus (indikatiivne), edasikäigul		
[24]	Liikumiskiirus (indikatiivne), tagasikäigul		
[25]	mass		
[26]	A=pikkus		
[27]	B=samm		
[28]	C=kõrgus		
[29]	D=laius		
[30]	Helivõimsuse mõõdetav tase		
[31]	Määramatus		
[32]	Helivõimsuse kindel tase		
[33]	Helirõhu tase		
[34]	Määramatus		
[35]	Vibratsioonid juhikohal		
[36]	Määramatus		
[37]	Vibratsioonid roolil		
[38]	Määramatus		
[39]	TELLIMUSEL LISATARVIKUD		
[40]	Kirjeldus		
[41]	Treiler		
[42]	Väetaja		

## 0 TEKNISTEN TIETOJEN TAULUKKO

[1]	Tyyppi	[41]	Perävaunu
[2]	Malli	[42]	Lannoitin
[3]	Moottori	[43]	Ruoho -ja lehtikerääjä
[4]	Sylinteritilavuus	[44]	Harava
[5]	Veto	[45]	Lumiketjut
[6]	Teho	[46]	Muta-/talvipyörät
[7]	Moottorin kierrosluku	[47]	Leikkuulaiteyksikkö
[8]	Sähkölaiteisto	[48]	Etuäes
[9]	Akku	[49]	Silppuri
[10]	Polttoneste	[50]	Turbiinilumilinko
[A]	Lyijytön bensiini	[51]	Etuharjalaite
[11]	Polttonestesäiliön tilavuus	[52]	Lumiaura
[12]	Moottoriöljy	[53]	Ilmastin/jyrsin
[13]	Moottoriöljy, luokitus	[54]	Takapyörän vastapainot
[A]	SJ tai suurempi	[55]	Lisävarusteiden takanostin
[14]	Moottoriöljysäiliön tilavuus ilman suodattimen vaihtoa	[56]	(**) 2WD-malleissa on asennettava vastapainot takapyöriin.
[15]	Moottoriöljysäiliön tilavuus suodattimen vaihdon kanssa	[57]	LISÄVARUSTEIDEN OIKEAOPPISEN YHDISTELYN TAULUKKO
[16]	Vaihteistoöljy	[58]	TAKAVARUSTE
[17]	Vaihteistoöljyn määrä vaihdon hetkellä	[59]	ETUVARUSTE
[18]	Sytytystulppa	[60]	Lisävaruste
[A]	Champion XC12YC tai vastaava	[61]	(***) 2WD-malleissa , joissa on samanaikaisesti tyypin 110C E, 110C E QF, 125C E QF -leikkuulaitteet ja perävaunu, takapyöriin on asennettava vastapainot.
[19]	Sytytystulppa, elektrodien välinen etäisyys		
[20]	Renkaat		
[21]	Renkaiden paine		etu taka
[22]	Leikkuukorkeus		
[A]	Katso tietoja leikkuukorkeudesta leikkuulaiteoppaan teknisten tietojen taulukosta.		
[23]	Etenemisnopeus (suuntaa-antava), eteenpäin mentäessä		
[24]	Etenemisnopeus (suuntaa-antava), peruutettaessa		
[25]	Massa		
[26]	A = pituus		
[27]	B = akseliväli		
[28]	C = korkeus		
[29]	D = leveys		
[30]	Mitattu äänitehotaso		
[31]	Epävarmuus		
[32]	Taattu äänitehotaso		
[33]	Äänenpainetaso		
[34]	Epävarmuus		
[35]	Värinäarvo ajajan paikalla		
[36]	Epävarmuus		
[37]	Värinäarvo ohjauspyörään		
[38]	Epävarmuus		
[39]	TILATTAVAT LISÄVARUSTEET		
[40]	Kuvaus		

## 0 TABLEAU DONNÉES TECHNIQUES

[1]	Type	[40]	Description
[2]	Modèle	[41]	Remorque
[3]	Moteur	[42]	Fertiliseur
[4]	Cylindrée	[43]	Ramasse feuilles et herbe
[5]	Traction	[44]	Râteau
[6]	Puissance	[45]	Chaînes à neige
[7]	Tours moteur	[46]	Roues complètes boue / neige
[8]	Installation électrique	[47]	Ensemble du dispositif de coupe
[9]	Batterie	[48]	Herse frontale
[10]	Carburant	[49]	Dispositif à hacher
[A]	Essence sans plomb	[50]	Chasse-neige à turbine
[11]	Capacité du réservoir de carburant	[51]	Balayeuse frontale
[12]	Huile moteur	[52]	Chasse-neige à lame
[13]	Huile moteur, classe de service	[53]	Aérateur/scarificateur
[A]	SJ ou supérieure	[54]	Contrepoids roues arrière
[14]	Capacité du réservoir huile moteur, sans remplacement du filtre	[55]	Élévateur arrière pour accessoires
[15]	Capacité du réservoir huile moteur, avec remplacement du filtre	[56]	(**) Pour les modèles à 2 roues motrices, il est obligatoire d'installer les contrepoids sur les roues arrière.
[16]	Huile de transmission	[57]	TABLEAU POUR LA CORRECTE COMBINAISON DES ACCESSOIRES
[17]	Quantité huile de transmission au moment de la vidange	[58]	ACCESSOIRES ARRIÈRE
[18]	Bougie	[59]	ACCESSOIRES FRONTAUX
[A]	Champion XC12YC ou équivalente	[60]	Accessoire
[19]	Bougie, distance des électrodes	[61]	(***) Pour les modèles à 2 roues motrices, avec l'application en même temps de l'ensemble des dispositifs de coupe « type 110C E, 110C E QF, 125C E QF » et de la remorque, il est obligatoire d'installer les contrepoids sur les roues arrière.
[20]	Pneus		
[21]	Pression des pneus		avant arrière
[22]	Hauteur de coupe		
[A]	Pour la hauteur de coupe, voir le « Tableau Données Techniques » du manuel « ensemble du dispositif de coupe »		
[23]	Vitesse d'avancement (indicative), en marche avant		
[24]	Vitesse d'avancement (indicative), en marche arrière		
[25]	Masse		
[26]	A = Longueur		
[27]	B = Pas		
[28]	C = Hauteur		
[29]	D = Largeur		
[30]	Niveau de puissance sonore mesuré		
[31]	Incertitude		
[32]	Niveau de puissance sonore garanti		
[33]	Niveau de pression sonore		
[34]	Incertitude		
[35]	Valeur des vibrations au poste de conduite		
[36]	Incertitude		
[37]	Valeur des vibrations au volant		
[38]	Incertitude		
[39]	ACCESSOIRES SUR DEMANDE		

## 0 TABLICA S TEHNIČKIM PODACIMA

[1]	Tip	[42]	Uređaj za gnojenje
[2]	Model	[43]	Uređaj za skupljanje lišća i trave
[3]	Motor	[44]	Grablje
[4]	Obujam	[45]	Lanci za snijeg
[5]	Trakcija	[46]	Kotači za blato/snijeg
[6]	Snaga	[47]	Rezno kućište
[7]	Broj okretaja motora	[48]	Prednja drljača
[8]	Električni sustav	[49]	Uređaj za ustinjavanje
[9]	Baterija	[50]	Turbinski čistač snijega
[10]	Gorivo	[51]	Prednji čistač snijega
[A]	Bezolovni benzin	[52]	Čistač snijega sa sječivima
[11]	Obujam spremnika za gorivo	[53]	Provetrilač
[12]	Motorno ulje	[54]	Protuv tegovi za zadnje kotače
[13]	Klasa motornog ulja	[55]	Zadnji podizač dodatnog pribora
[A]	SJ ili više	[56]	(**) Kod modela s trakcijom na 2 kotača, na zadnje kotače morate staviti protuv tegove.
[14]	Obujam spremnika za ulje motora, bez zamene filtera	[57]	TABLICA ZA PRAVILNO KOMBINIRANJE DODATNOG PRIBORA
[15]	Obujam spremnika za ulje, sa zamenom filtera	[58]	ZADNJI DODATNI PRIBOG
[16]	Ulje za menjač	[59]	PREDNJI DODATNI PRIBOG
[17]	Količina ulja za mjenjač u prilikom zamjene	[60]	Pribor
[18]	Svjećica	[61]	(***) Kod modela s trakcijom na 2 kotača, prilikom istodobne uporabe reznog kućišta "110C E, 110C E QF, 125C E QF" i prikolice na zadnje kotače morate staviti protuv tegove.
[A]	Champion XC12YC ili slično		
[19]	Svjećica, razmak elektroda		
[20]	Gume		
[21]	Plak guma		prednje zadnje
[22]	Visina rezanja		
[A]	Za visinu rezanja pogledajte Tablicu s tehničkim podacima" u priručniku za "režno kućište"		
[23]	Brzina hoda (indikativna) prema naprijed		
[24]	Brzina hoda (indikativna) prema nazad		
[25]	Masa		
[26]	A = Dužina		
[27]	B = Hod		
[28]	C = Visina		
[29]	D = Širina		
[30]	Izmerena razina zvučne snage		
[31]	Neizvjesnost		
[32]	Garantovana razina zvučne snage		
[33]	Razina zvučnog tlaka		
[34]	Neizvesnost		
[35]	Vrijednost vibracija na vozačevom mjestu		
[36]	Neizvjesnost		
[37]	Vrijednost vibracija na upravljaču		
[38]	Neizvjesnost		
[39]	DODATNI PRIBOR NA UPIT		
[40]	Opis		
[41]	Prikolica		

## 0 MŰSZAKI ADATOK TÁBLÁZATA

[1]	Típus	[41]	Utánfutó
[2]	Modell	[42]	Permetező
[3]	Motor	[43]	Levél- és fűgyűjtő
[4]	Hengerűrtartalom	[44]	Lombseprű
[5]	Meghajtás	[45]	Hólánc
[6]	Teljesítmény	[46]	Sár- és hókerekek
[7]	Fordulatszám	[47]	Nyíróberendezés
[8]	Elektromos berendezés	[48]	Front borona
[9]	Akkumulátor	[49]	Szárzúzó
[10]	Üzemanyag	[50]	Turbós hómaró
[A]	Ólommentes benzin	[51]	Front seprű
[11]	Üzemanyagtartály térfogata	[52]	Késes hókotró
[12]	Motorolaj	[53]	Mélyszellőztető/gyeplazító
[13]	Motorolaj, szervoszertály	[54]	Keréksúlyok hátsó kerekekhez
[A]	SJ vagy magasabb	[55]	Hátsó tartozékemelő
[14]	Motorolajtartály térfogata szűrőcsere nélkül	[56]	(***) A kétkerék-meghajtású modelleknél kötelező a hátsó kerekekre a keréksúlyokat felszerelni.
[15]	Motorolajtartály térfogata szűrőcserével	[57]	TARTOZÉKOK HELYES KOMBINÁCIÓJA TÁBLÁZAT
[16]	Hajtóműolaj	[58]	HÁTSÓ TARTOZÉKOK
[17]	Hajtóműolaj mennyisége olajcserénél	[59]	FRONT TARTOZÉKOK
[18]	Gyújtógyertya	[60]	Tartozék
[A]	Champion XC12YC vagy egyenértékű	[61]	(***) A kétkerék-meghajtású modelleknél kötelező a hátsó kerekekre a keréksúlyokat felszerelni, amikor egyszerre használja a "110C E, 110C E QF, 125C E QF típusú" nyíróberendezést és az utánfutót.
[19]	Gyújtógyertya, elektródok távolsága		
[20]	Abroncok		
[21]	Abroncok nyomása		első hátsó
[22]	Vágásmagasság		
[A]	A vágásmagasságról lásd a nyíróberendezés használati utasításában a "Műszaki adatok táblázatát"-t		
[23]	Haladási sebesség (hozzávetőleges) előremenetben		
[24]	Haladási sebesség (hozzávetőleges) hátramenetben		
[25]	Súly		
[26]	A = hossz		
[27]	B = tengelytáv		
[28]	C = magasság		
[29]	D = szélesség		
[30]	Mért hangteljesítmény		
[31]	Pontatlanság		
[32]	Garantált hangteljesítmény		
[33]	Hangnyomás szint		
[34]	Pontatlanság		
[35]	Rezgések értéke vezetőülésnél		
[36]	Pontatlanság		
[37]	Rezgések értéke kormánykeréknél		
[38]	Pontatlanság		
[39]	RENDELHETŐ TARTOZÉKOK		
[40]	Megnevezés		



## 0 TECHNINIŲ DUOMENŲ LENTELĖ

[1]	Tipas	[43]	Lapų ir žolių rinktuvai
[2]	Modelis	[44]	Grėblys
[3]	Variklis	[45]	Sniego grandinės
[4]	Tūris	[46]	Ratai purvui / sniegui
[5]	Trauka	[47]	Pjovimo prietaiso agregatas
[6]	Galia	[48]	Priekinės akėčios
[7]	Variklio apšukos	[49]	Smulkintuvas
[8]	Elektros sistema	[50]	Turbininis sniego valytuvas
[9]	Akumulatorius	[51]	Priekinis šlavimo prietaisas
[10]	Degalai	[52]	Peilinis sniego valytuvas
[A]	Bešvinis benzinas	[53]	Aeratorius/skarifikatorius
[11]	Degalų bako talpa	[54]	Galinių ratų atsvarai
[12]	Variklio alyva	[55]	Galinis priedų kėlimo prietaisas
[13]	Variklio alyva, kokybės klasė	[56]	(**) Modeliuose „2WD“ ant galinių ratų privaloma sumontuoti atsvarus.
[A]	SJ ar aukštesnė	[57]	TEISINGOS PRIEDŲ KOMBINACIJOS LENTELĖ
[14]	Variklio alyvos talpos tūris, nekeičiant filtro	[58]	GALINIAI PRIEDAI
[15]	Variklio alyvos talpos tūris, keičiant filtrą	[59]	PRIEKINIAI PRIEDAI
[16]	Transmisinė alyva	[60]	Priedas
[17]	Transmisinės alyvos kiekis keitimo metu	[61]	(***) Modeliuose „2WD“ vienu metu naudojant 110C E, 110C E QF, 125C E QF tipo pjovimo prietaisų agregatus ir priekabą, ant galinių ratų privaloma sumontuoti atsvarus.
[18]	Žvakė		
[A]	„Champion XC12YC“ ar panašus		
[19]	Tarpai tarp žvakės elektrodų		
[20]	Padangos		
[21]	Oro slėgis padangose		priekinėse galinėse
[22]	Pjūvio aukštis		
[A]	Pjūvio aukštį žr. pjovimo agregato instrukcijoje „Techninių duomenų lentelėje“.		
[23]	Važiavimo greitis (apytikris), priekine eiga		
[24]	Važiavimo greitis (apytikris), atbuline eiga		
[25]	Svoris		
[26]	A = Ilgis		
[27]	B = Žingsnis		
[28]	C = Aukštis		
[29]	D = Plotis		
[30]	Išmatuota garso lygio galia		
[31]	Paklaida		
[32]	Garantuota garso lygio galia		
[33]	Garso slėgio lygis		
[34]	Paklaida		
[35]	Vibracija vairuotojo vietoje		
[36]	Paklaida		
[37]	Vairo vibracija		
[38]	Paklaida		
[39]	PRIEDAI, KURIUOS GALIMA UŽSISAKYTI		
[40]	Aprašymas		
[41]	Priekaba		
[42]	Tręštuvai		

## 0 TEHNISKO DATU TABULA

[1]	Tips	[43]	Lapu un zāles savācējs
[2]	Modelis	[44]	Grābeklis
[3]	Dzinējs	[45]	Sniega ķēdes
[4]	Tilpums	[46]	Dubļu/sniega riteņi
[5]	Sajūgs	[47]	Plaušanas ierīces komplekts
[6]	Jauda	[48]	Priekšējā ecēšanas ierīce
[7]	Dzinēja apgriezību skaits	[49]	Smalcinātājs
[8]	Elektriskā sistēma	[50]	Sniega tīrītājs ar turbīnu
[9]	Akumulators	[51]	Priekšējā slaucīšanas mašīna
[10]	Degviela	[52]	Sniega tīrītājs ar vērstuvi
[A]	Benzīns bez svina	[53]	Irdinātājs/skarifikators
[11]	Degvielas tvertnes tilpums	[54]	Aizmugurējo riteņu pretsvāri
[12]	Motoreļļa	[55]	Piederumu aizmugurējais pacelājs
[13]	Dzinēja eļļa, pakalpojuma kategorija	[56]	(**) 2WD modeļiem obligāti jāuzstāda uz aizmugurējiem riteņiem atsvari.
[A]	SJ vai augstāka	[57]	TABULA PAREIZAI PIEDERUMU KOMBINĀCIJAI
[14]	Dzinēja eļļas tvertnes tilpums, nemainot filtru	[58]	AIZMUGURES PIEDERUMI
[15]	Dzinēja eļļas tvertnes tilpums, nomainot filtru	[59]	PRIEKŠĒJIE PIEDERUMI
[16]	Transmisijas eļļa	[60]	Piederums
[17]	Transmisijas eļļas daudzums tās nomaiņas brīdī	[61]	(***)2WD modeļiem, vienlaicīgu piemērojot "110C E, 110C E QF, 125C E QF tipa" griešanas ierīces komplektu un piekabi, ir obligāti jāuzstāda uz aizmugurējiem riteņiem atsvari.
[18]	Svece		
[A]	Champion XC12YC vai līdzvērtīgs		
[19]	Svece, elektrodu atstarpe		
[20]	Riepas		
[21]	Riepu spiediens		priekšējo aizmugurējo
[22]	Plaušanas augstums		
[A]	Plaušanas augstumam, skatiet "Tehnisko datu tabulu" rokasgrāmatā "Plaušanas ierīces komplekts"		
[23]	Kustības ātrums (aptuvenus), uz priekšu		
[24]	Kustības ātrums (aptuvenus), atpakaļgaitas		
[25]	Svars		
[26]	A = Garums		
[27]	B = Solis		
[28]	C = Augstums		
[29]	D = Platums		
[30]	Mērītās skaņas jaudas līmenis:		
[31]	Nenoteiktība		
[32]	Garantētās skaņas jaudas līmenis		
[33]	Skaņas spiediena līmenis		
[34]	Nenoteiktība		
[35]	Vibrāciju vērtība vadītāja sēdekļī		
[36]	Nenoteiktība		
[37]	Vibrācijas vērtība pie stūres		
[38]	Nenoteiktība		
[39]	PIEDERUMI PĒC PIEPRASĪJUMA		
[40]	Apraksts		
[41]	Piekabe		
[42]	Mēslojātājs		

## 0 TABEL TECHNISCHE GEGEVENS

[1]	Type	[39]	OPTIONELE ACCESSOIRES
[2]	Model	[40]	Beschrijving
[3]	Motor	[41]	Aanhanger
[4]	Cilinderinhoud	[42]	Mestverspreider
[5]	Tractie	[43]	Bladeren- en grasopvangbak
[6]	Vermogen	[44]	Verticuteermachine
[7]	Motortoeren	[45]	Sneeuwkettingen
[8]	Elektrisch systeem	[46]	Modderwielen/sneeuwwielen
[9]	Accu	[47]	Maaisysteemgroep
[10]	Brandstof	[48]	Eg aan voorzijde
[A]	Loodvrije benzine	[49]	Hakselaar
[11]	Inhoud brandstoftank	[50]	Roterende sneeuwruimer
[12]	Motorolie	[51]	Frontborstel
[13]	Motorolie, klasse	[52]	Sneeuwruimer met sneeuwschuif
[A]	SJ of hoger	[53]	Bodemventilator/verticuleermachine
[14]	Inhoud motoroliereservoir, zonder vervanging van het filter	[54]	Tegengewichten achterwielen
[15]	Inhoud motoroliereservoir, met vervanging van het filter	[55]	Hefstelsel achterzijde voor accessoires
[16]	Transmissieolie	[56]	(**) Voor de 2WD modellen is het verplicht om tegengewichten om de achterwielen te installeren.
[17]	Hoeveelheid transmissieolie op het moment van de verversing	[57]	TABEL VOOR DE JUISTE COMBINATIE VAN ACCESSOIRES
[18]	Bougie	[58]	ACCESSOIRES ACHTERZIJDE
[A]	Champion XC12YC of equivalent	[59]	ACCESSOIRES VOORZIJDE
[19]	Bougie, afstand elektroden	[60]	Accessoire
[20]	Banden	[61]	(***) Voor de 2WD modellen is het, met gelijktijdig gebruik van de maaisysteemgroep "type 110C E, 110C E QF, 125C E QF" en de aanhanger, verplicht om tegengewichten om de achterwielen te installeren.
[21]	Bandenspanning		
			voor
			achter
[22]	Maaihoogte		
[A]	Zie voor de maaihoogte de "Tabel technische gegevens" van de handleiding van de "maaisysteemgroep"		
[23]	Rijsnelheid (bij benadering), vooruit		
[24]	Rijsnelheid (bij benadering), achteruit		
[25]	Gewicht		
[26]	A = Lengte		
[27]	B = Wielbasis		
[28]	C = Hoogte		
[29]	D = Breedte		
[30]	Gemeten geluidsvermogeniveau		
[31]	Onzekerheid		
[32]	Gegarandeerd geluidsvermogeniveau		
[33]	Geluidsdruk niveau		
[34]	Onzekerheid		
[35]	Waarde van de trillingen op de bestuurdersplaats		
[36]	Onzekerheid		
[37]	Waarde van de trillingen aan het stuurwiel		
[38]	Onzekerheid		

## 0 TABELL - TEKNISKE DATA

[1]	Type	[43]	Blad- og gressoppsamler
[2]	Modell	[44]	Rive
[3]	Motor	[45]	Snøkettinger
[4]	Slagvolum	[46]	Gjørme-/snøhjul
[5]	Fremdrift	[47]	Klippeaggregat
[6]	Motoreffekt	[48]	Frontmontert harve
[7]	Motoromdreininger	[49]	Skjæreaggregat
[8]	Elektrisk anlegg	[50]	Snøfreser med turbin
[9]	Batteri	[51]	Frontmontert feieaggregat
[10]	Drivstoff	[52]	Snøplog med vinge
[A]	Blyfri bensin	[53]	Plenlufter/kultivator
[11]	Kapasitet drivstofftank	[54]	Motvekt bakhjul
[12]	Motorolje	[55]	Bakmontert redskapsløfter
[13]	Motorolje, serviceklasse	[56]	(**) På 2WD-modellene er det påbudt å sette motvekt på bakhjulene.
[A]	SJ eller høyere	[57]	TABELL FOR KORREKT KOMBINERT BRUK AV TILBEHØR
[14]	Kapasitet motoroljebeholder, uten filterskifte	[58]	BAKMONTERTE TILBEHØR
[15]	Kapasitet motoroljetank, med skifte av filter	[59]	FRONTMONTERTE TILBEHØR
[16]	Transmisjonsolje	[60]	Tilbehør
[17]	Mengde transmisjonsolje ved skifte	[61]	(***) På 2WD-modellene hvor man kan bruke klippe- redskap "type 110C E, 110C E QF, 125C E QF" og tilhenger samtidig er det påbudt å sette motvekt på bakhjulene.
[18]	Tennplugg		
[A]	Champion XC12YC eller tilsvarende		
[19]	Tennplugg, elektrodeavstand		
[20]	Dekk		
[21]	Dekktrykk		foran
			bak
[22]	Klippehøyde		
[A]	Sjekk klippehøyden i "Tabell over tekniske data" i håndboken for klippeaggregatet		
[23]	Fremdriftshastighet (veil.) forover		
[24]	Fremdriftshastighet (veil.) bakover		
[25]	Maskinens totalvekt		
[26]	A = Lengde		
[27]	B = Akselavstand		
[28]	C = Høyde		
[29]	D = Bredde		
[30]	Målt lydstyrkenivå		
[31]	Toleranse		
[32]	Garantert lydstyrkenivå		
[33]	Lydtryknivå		
[34]	Toleranse		
[35]	Vibrasjonsverdier ved førerplassen		
[36]	Toleranse		
[37]	Vibrasjonsverdier ratt		
[38]	Toleranse		
[39]	TILLEGGSTYR PÅ FORESPØRSEL		
[40]	Beskrivelse		
[41]	Tilhenger		
[42]	Gjødselspreder		

## 0 TABELA DANYCH TECHNICZNYCH

[1]	Typ	[41]	Przyczepa
[2]	Model	[42]	Urządzenie do nawożenia
[3]	Silnik	[43]	Urządzenie do zbierania liści i trawy
[4]	Pojemność skokowa	[44]	Zgrabiarka
[5]	Napęd	[45]	Łańcuchy śniegowe
[6]	Moc	[46]	Koła błotne / śnieżne
[7]	Obroty silnika	[47]	Zespół urządzenia tnącego
[8]	Instalacja elektryczna	[48]	Brona przednia
[9]	Akumulator	[49]	Kruszarka
[10]	Paliwo	[50]	Odśnieżarka turbinowa
[A]	Benzyna bezołowiowa	[51]	Zamiatarka przednia
[11]	Pojemność zbiornika paliwa	[52]	Plug śnieżny z ostrzem
[12]	Olej silnikowy	[53]	Aerator/ skaryfikator
[13]	Olej silnikowy, klasa użytkowa	[54]	Przeciwcieżary tylnych kół
[A]	SJ lub wyższy	[55]	Tylny podnośnik dla akcesoriów
[14]	Pojemność miski olejowej silnika, bez wymiany filtra	[56]	(**) W modelach 2WD obowiązkowe jest zainstalowanie przeciwcieżarów na tylnych kołach.
[15]	Pojemność miski olejowej silnika z wymianą filtra	[57]	TABELA WŁAŚCIWEGO ŁĄCZENIA AKCESORIÓW
[16]	Olej przekładniowy	[58]	AKCESORIA TYLNE
[17]	Ilość oleju przekładniowego w chwili wymiany	[59]	AKCESORIA PRZEDNIE
[18]	Świeca zapłonowa	[60]	Akcesorium
[A]	Champion XC12YC lub równoważny	[61]	(***) W modelach 2WD, przy jednoczesnym zastosowaniu zespołów urządzeń tnących "typ 110C E, 110C E QF, 125C E QF" i przyczepy, obowiązkowe jest zainstalowanie przeciwcieżarów na tylnych kołach.
[19]	Świeca, odległość elektrod		
[20]	Opony		
[21]	Ciśnienie w oponach		
		przód	
		tył	
[22]	Wysokość koszenia		
[A]	Odnośnie wysokości koszenia patrz "Tabela Danych Technicznych" w instrukcji "zespołu urządzenia tnącego".		
[23]	Prędkość jazdy (orientacyjnie) podczas ruchu do przodu		
[24]	Prędkość jazdy (orientacyjnie) podczas ruchu do tyłu		
[25]	Ciążar		
[26]	A = Długość		
[27]	B = Odstęp		
[28]	C = Wysokość		
[29]	D = Szerokość		
[30]	Mierzony poziom mocy akustycznej		
[31]	Margines niepewności		
[32]	Gwarantowany poziom mocy akustycznej		
[33]	Poziom ciśnienia akustycznego		
[34]	Margines niepewności		
[35]	Wartość wibracji na stanowisku kierowcy		
[36]	Margines niepewności		
[37]	Wartość wibracji przy kierownicy		
[38]	Margines niepewności		
[39]	AKCESORIA DOSTĘPNE NA ZAMÓWIENIE		
[40]	Opis		

## 0 TÉCNICO TABELA DE DADOS

[1]	Tipo	[37]	Valor das vibrações no volante
[2]	Modelo	[38]	Incerteza
[3]	Motor	[39]	ACESSÓRIOS A PEDIDO
[4]	Cilindrada	[40]	Descrição
[5]	Tração	[41]	Reboque
[6]	Potência	[42]	Fertilizador
[7]	Rotações do motor	[43]	Recolhedor de folhas e erva
[8]	Equipamento elétrico	[44]	Ancinho
[9]	Bateria	[45]	Correntes de neve
[10]	Combustível	[46]	Rodas para lama / neve
[A]	Benzina sem chumbo	[47]	Conjunto do dispositivo de corte
[11]	Capacidade reservatório de combustível	[48]	Grade frontal
[12]	Óleo motor	[49]	Máquina de cortar
[13]	Óleo motor, classe de serviço	[50]	Dispositivo para remover a neve de turbina
[A]	SJ ou superior	[51]	Vassoura frontal
[14]	Capacidade do reservatório de óleo do motor, sem substituição do filtro	[52]	Dispositivo para remover a neve de lâmina
[15]	Capacidade do reservatório de óleo do motor, com substituição do filtro	[53]	Arejador/escarificador
[16]	Óleo Transmissão	[54]	Contrapeso rodas posteriores
[17]	Quantidade de óleo da transmissão no momento da substituição	[55]	Sistema de elevação posterior para acessórios
[18]	Vela	[56]	(**) Para os modelos 2WD, é obrigatório instalar os contrapesos nas rodas posteriores.
[A]	Champion XC12YC ou equivalente	[57]	TABELA PARA A CORRETA COMBINAÇÃO DOS ACESSÓRIOS
[19]	Vela, distância eléctrodos	[58]	ACESSÓRIOS POSTERIORES
[20]	Pneus	[59]	ACESSÓRIOS FRONTAIS
[21]	Pressão dos pneus.	[60]	Acessório
			(***) Nos modelos 2WD, com a aplicação simultânea de todos os dispositivos de corte "tipo 110C E, 110C E QF, 125C E QF" e de reboque é obrigatório instalar os contrapesos nas rodas posteriores.
		[61]	
[22]	Altura de corte		
[A]	Per l'altezza di taglio, vedere la "Tabella Dati Tecnici" del manuale "assieme del dispositivo di taglio" Para a altura de corte consultar a "Tabela de Dados Técnicos" do manual "conjunto do dispositivo de corte"		
[23]	Velocidade de progresso (indicativa), em marcha à frente		
[24]	Velocidade de progresso (indicativa), em marcha-atrás		
[25]	Massa		
[26]	A = Comprimento		
[27]	B = Passo		
[28]	C = Altura		
[29]	D = Largura		
[30]	Nível de potência sonora medido		
[31]	Incerteza		
[32]	Nível de potência sonora garantido		
[33]	Nível de pressão sonora		
[34]	Incerteza		
[35]	Valor das vibrações no posto de condução		
[36]	Incerteza		

## 0 ТАБЛИЦА ТЕХНИЧЕСКИХ ДАННЫХ

[1]	Тип	[38]	Погрешность
[2]	Модель	[39]	ПРИНАДЛЕЖНОСТИ – НАВЕСНЫЕ ОРУДИЯ ПО ЗАКАЗУ
[3]	Двигатель	[40]	Описание
[4]	Объем цилиндров	[41]	Прицеп
[5]	Привод	[42]	Устройство для разбрасывания удобрений
[6]	Мощность	[43]	Устройство для сбора листьев и травы
[7]	Обороты двигателя	[44]	Грабли
[8]	Электроустанова	[45]	Цепи противоскольжения
[9]	Аккумулятор	[46]	Колеса для грязи / снега
[10]	Топливо	[47]	Режущий узел
[A]	Неэтилированный бензин.	[48]	Фронтальный рыхлитель
[11]	Емкость топливного бака	[49]	Измельчитель
[12]	Масло двигателя	[50]	Турбинный снегоочиститель
[13]	Масло двигателя, эксплуатационный класс	[51]	Фронтальное подметально-уборочное устройство
[A]	SJ или выше	[52]	Шнекороторный снегоочиститель
[14]	Емкость бака для масла двигателя, без замены фильтра	[53]	Рыхлитель/культиватор
[15]	Емкость бака для масла двигателя, с заменой фильтра	[54]	Противовесы задних колес
[16]	Масло коробки передач	[55]	Заднее устройство подъема навесных орудий
[17]	Количество масла коробки передач в момент замены	[56]	(**) В моделях 2WD следует обязательно установить на задние колеса противовесы.
[18]	Свеча зажигания	[57]	ТАБЛИЦА ПРАВИЛЬНОГО СОЧЕТАНИЯ ПРИНАДЛЕЖНОСТЕЙ – НАВЕСНЫХ ОРУДИЙ
[A]	"Champion" XC12YC или эквивалентная	[58]	ЗАДНИЕ НАВЕСНЫЕ ОРУДИЯ
[19]	Свеча зажигания, расстояние между электродами	[59]	ФРОНТАЛЬНЫЕ НАВЕСНЫЕ ОРУДИЯ
[20]	Шины	[60]	Навесное орудие
[21]	Давление в шинах	[61]	(***) При одновременном использовании режущего узла типа 110С E, 110С E QF, 125С E QF и прицепа в моделях 2WD следует обязательно установить на задние колеса противовесы.
			передние
			задние
[22]	Высота стрижки		
[A]	Высоту стрижки см. в "Таблице технических данных" руководства режущего узла		
[23]	Скорость хода (ориентировочная) при движении вперед		
[24]	Скорость хода (ориентировочная) при движении задним ходом		
[25]	Масса		
[26]	A = Длина		
[27]	B = Межосевое расстояние		
[28]	C = Высота		
[29]	D = Ширина		
[30]	Уровень измеренной звуковой мощности		
[31]	Погрешность		
[32]	Уровень звуковой мощности гарантированный		
[33]	Уровень звукового давления		
[34]	Погрешность		
[35]	Уровень вибрации на месте водителя		
[36]	Погрешность		
[37]	Уровень вибрации на рулевом колесе		

## 0 TABELA S TEHNIČNIMI PODATKI

[1]	Tip	[42]	Gnojilo
[2]	Model	[43]	Zbiralna posoda za listje in travo
[3]	Motor	[44]	Grablje
[4]	Cilindri	[45]	Snežne verige
[5]	Oprijem	[46]	Kolesa za blato / sneg
[6]	Moč	[47]	Sklop naprave za rezanje (košnja)
[7]	Obrati motorja	[48]	Frontalna brana
[8]	Električni sistem	[49]	Mulčer
[9]	Akumulator	[50]	Turbinski snežni plug
[10]	Gorivo	[51]	Naprava za pometanje cest - frontalni priključek
[A]	Neosvinčen bencin	[52]	Odmetalnik snega
[11]	Kapaciteta rezervoarja za gorivo	[53]	Kultivator/Rahljalnik
[12]	Motorno olje	[54]	Kontrauteži za zadnja kolesa
[13]	Motorno olje, delovni razred	[55]	Naprava za dviganje dodatnih priključkov - zadaj
[A]	SJ ali višje	[56]	(**) Pri modelih 2WD je potrebno namestiti kontrauteži na zadnja kolesa.
[14]	Kapaciteta rezervoarja motornega olja, brez zamenjave filtra	[57]	TABELA ZA PRAVILNO KOMBINACIJO DODATNIH PRIKLJUČKOV
[15]	Kapaciteta rezervoarja motornega olja, z zamenjavo filtra	[58]	ZADNJI PRIKLJUČKI
[16]	Olje v menjalniku	[59]	SPREDNJI PRIKLJUČKI
[17]	Količina olja v menjalniku v trenutku menjave	[60]	Dodatni priključek
[18]	Svečka	[61]	(***) Pri modelih 2WD je potrebno pri hkratni namestitvi naprav za rezanje "tip 110C E, 110C E QF, 125C E QF" in priklopnika namestiti kontrauteži na zadnja kolesa.
[A]	Champion XC12YC ali enako		
[19]	Svečka, razdalja od elektrod		
[20]	Pnevmatike		
[21]	Pritisk v pnevmatikah		
			sprednje
			zadnje
[22]	Višina košnje		
[A]	Za višino košnje glejte "Tabelo s tehničnimi podatki" v priložniku "Sklopa Plošče za rezanje"		
[23]	Hitrost napredovanja (indikativna) pri vožnji naprej		
[24]	Hitrost napredovanja (indikativna) pri vzratni vožnji		
[25]	Masa		
[26]	A = Dolžina		
[27]	B = Korak		
[28]	C = Višina		
[29]	D = Širina		
[30]	Raven izmerjene zvočne moči		
[31]	Negotovost		
[32]	Raven zagotovljene zvočne moči		
[33]	Raven zvočnega pritiska		
[34]	Negotovost		
[35]	Raven vibracij na voznikovem sedežu		
[36]	Negotovost		
[37]	Raven tresljajev na volanu		
[38]	Negotovost		
[39]	DODATNI PRIKLJUČKI NA ZAHTEVO		
[40]	Opis		
[41]	Priklopnik		



## 0 TABELL MED TEKNISKA DATA

[1]	Typ	[43]	Blad- och gräsupsamlare
[2]	Modell	[44]	Kratta
[3]	Motor	[45]	Snökedjor
[4]	Cylindervolym	[46]	Hjul för lera/snö
[5]	Dragkraft	[47]	Klippaggregat
[6]	Effekt	[48]	Främre jordfräs
[7]	Motorvarvtal	[49]	Kompostkvarn
[8]	Elsystem	[50]	Snöslunga med turbin
[9]	Batteri	[51]	Främre borste
[10]	Bränsle	[52]	Snöröjare med blad
[A]	Blyfri bensin	[53]	Luftare/vertikalskärare
[11]	Volym bränsletank	[54]	Motvikter för bakhjul
[12]	Motorolja	[55]	Bakre tillbehörslyft
[13]	Motorolja, serviceklass	[56]	(**) För modell 2WD är det obligatoriskt att installera motvikter på bakhjulen.
[A]	SJ eller högre	[57]	TABELL ÖVER KORREKT KOMBINATION AV TILLBEHÖR
[14]	Volym motoroljetank, utan filterbyte	[58]	BAKRE TILLBEHÖR
[15]	Volym motoroljetank, med filterbyte	[59]	FRÄMRE TILLBEHÖR
[16]	Transmissionsolja	[60]	Tillbehör
[17]	Mängd transmissionsolja vid byte	[61]	(***) För modellerna 2WD, med samtidig användning av skärutrustning "typ 110C E, 110C E QF, 125C E QF" och av bogseringsutrustning är det obligatoriskt att installera motvikter på bakhjulen.
[18]	Tändstift		
[A]	Champion XC12YC eller motsvarande		
[19]	Tändstift, avstånd mellan elektroderna		
[20]	Däck		
[21]	Däcktryck		
		fram	
		bak	
[22]	Klipphöjd		
[A]	För klipphöjd, se tabellen med tekniska data i klippaggregatets manual.		
[23]	Hastighet (indikativ) vid körning framåt		
[24]	Hastighet (indikativ) vid backning		
[25]	Vikt		
[26]	A = Längd		
[27]	B = Hjulbas		
[28]	C = Höjd		
[29]	D = Bredd		
[30]	Mätt ljudeffektnivå		
[31]	Osäkerhet		
[32]	Garanterad ljudeffektnivå		
[33]	Ljudtrycksnivå		
[34]	Osäkerhet		
[35]	Vibrationer på förarplatsen		
[36]	Osäkerhet		
[37]	Rattvibrationer		
[38]	Osäkerhet		
[39]	TILLVALSTILLBEHÖR		
[40]	Beskrivning		
[41]	Släp		
[42]	Gödselspridare		



# 1 Table of Contents

<b>0</b>	<b>TECHNICAL DATA TABLE . . . . .</b>	<b>IX</b>
<b>1</b>	<b>INTRODUCTION . . . . .</b>	<b>4</b>
1.1	STRUCTURE OF THE MANUAL . . . . .	4
1.2	SYMBOLS . . . . .	4
1.3	TAKING CARE OF THE MANUAL . . . . .	4
<b>2</b>	<b>GETTING TO KNOW THE MACHINE . . . . .</b>	<b>4</b>
2.1	MODELS [2WD] . . . . .	4
2.2	MODELS [4WD] . . . . .	4
2.3	INTENDED USE . . . . .	5
2.3.1	DEFINITION OF THE TYPE OF USER . . . . .	5
2.4	IMPROPER USE . . . . .	5
2.5	SAFETY SIGNS . . . . .	5
2.5.1	Decals (4) . . . . .	5
2.6	PRODUCT IDENTIFICATION LABEL . . . . .	6
2.7	MAIN COMPONENTS . . . . .	6
<b>3</b>	<b>SAFETY REGULATIONS . . . . .</b>	<b>6</b>
3.1	TRAINING . . . . .	6
3.2	PREPARATION . . . . .	7
3.3	DURING OPERATION . . . . .	7
3.4	MAINTENANCE AND STORAGE . . . . .	9
3.5	TRANSPORTING . . . . .	10
3.6	ENVIRONMENTAL PROTECTION . . . . .	10
<b>4</b>	<b>INSURING YOUR LAWNMOWER . . . . .</b>	<b>11</b>
<b>5</b>	<b>ASSEMBLY . . . . .</b>	<b>11</b>
5.1	ASSEMBLY COMPONENTS (3) . . . . .	11
5.2	BONNET(5:A) . . . . .	11
5.3	BATTERY . . . . .	11
5.3.1	Battery connection (6) . . . . .	11
5.3.2	Battery charging . . . . .	11
5.4	SEAT (7) . . . . .	11
5.5	STEERING WHEEL (8) . . . . .	12
5.6	TOW BAR (9) . . . . .	12
5.7	QUICK-RELEASE SUPPORTS (1:N) . . . . .	12
5.8	TYRE PRESSURE . . . . .	12
5.9	ATTACHMENTS . . . . .	12
<b>6</b>	<b>CONTROLS . . . . .</b>	<b>12</b>
6.1	MECHANICAL ATTACHMENT LIFT PEDAL (10:C) . . . . .	12
6.2	PARKING BRAKE PEDAL (10:B) . . . . .	12
6.3	PARKING BRAKE LOCKING LEVER (10:A) . . . . .	13
6.4	TRACTION PEDAL (10:F) . . . . .	13

6.5	STEERING WHEEL (10: D)	13
6.6	THROTTLE AND CHOKE CONTROL [B&S Power Built] [B&S Intek] (if provided) (11:A)	13
6.7	THROTTLE CONTROL (ACCELERATOR) (12:A) MOD.: [B&S Vanguard]	13
6.8	CHOKE CONTROL (if provided) (12:B) - MOD.: [2WD]	13
6.9	IGNITION /HEADLIGHT BLOCK (11:C; 12:C)	14
6.10	POWER TAKE-OFF (11:D; 12:D)	14
6.11	HOUR METER (13:A)	14
6.12	CUTTING HEIGHT ADJUSTMENT (11:E; 12:E)	14
6.13	TRANSMISSION ENGAGE/DISENGAGE LEVER (14; 15)	14
6.14	SEAT ADJUSTMENT (16:B)	14
6.15	BONNET	15
6.16	QUICK-RELEASE SUPPORTS	15
<b>7</b>	<b>START-UP AND OPERATION</b>	<b>16</b>
7.1	PRECAUTIONS FOR USE	16
7.2	COMBINED USE OF ACCESSORIES	16
7.3	REFUELLING	16
7.4	CHECKING THE ENGINE OIL LEVEL (21; 22)	16
7.5	CHECKING THE TRANSMISSION FLUID LEVEL	16
7.6	SAFETY CHECKS	16
7.6.1	General safety check	17
7.6.2	Electrical safety check	17
7.7	START-UP / OPERATION	17
7.7.1	Operation	17
7.8	STOPPING	17
7.9	CLEANING	18
<b>8</b>	<b>USING THE ATTACHMENT</b>	<b>18</b>
8.1	CUTTING HEIGHT	18
8.2	MOWING TIPS	18
<b>9</b>	<b>MAINTENANCE</b>	<b>18</b>
9.1	ASSISTANCE PROGRAMME	18
9.2	PREPARATION	18
9.3	MAINTENANCE TABLE	19
9.4	TYRE PRESSURE	19
9.5	ENGINE OIL TOP-UP/CHANGE	19
9.5.1	Inspection / top-up (21; 22)	19
9.5.2	Oil change/filling (21; 22)	19
9.5.3	Replacing the oil filter (if present)	19
9.6	REPLACING THE FUEL FILTER (21:B, 22:B)	20
9.7	CHECKING/TOPPING UP THE TRANSMISSION FLUID [4WD]	20
9.7.1	Check/top-up (25)	20
9.7.2	Change	20
9.8	BELT TRANSMISSIONS CHECK	21
9.9	STEERING	21

9.9.1 Checks . . . . . 21

9.9.2 Adjustment (31) . . . . . 21

9.10 BATTERY . . . . . 21

9.10.1 Charging by the engine . . . . . 21

9.10.2 Charging with a battery charger . . . . . 21

9.10.3 Disassembly/assembly . . . . . 21

9.10.4 Cleaning . . . . . 22

9.11 AIR FILTER, ENGINE . . . . . 22

9.11.1 Cleaning / Replacement - mod.: [B&S Power Built] [B&S Intek] (32) . . . . . 22

9.11.2 Cleaning / Replacement - mod.: [B&S Vanguard] (33) . . . . . 22

9.11.3 Replace the spark plug. . . . . 22

9.11.4 Cleaning the air intake.. . . . 22

9.12 LUBRICATION (30) . . . . . 23

9.13 FUSES (34) . . . . . 23

**10 ASSISTANCE AND REPAIRS . . . . . 23**

**11 STORAGE . . . . . 24**

**12 TERMS OF PURCHASE. . . . . 25**

**13 MAINTENANCE SUMMARY TABLE . . . . .**

**14 TROUBLESHOOTING. . . . .**

## 1 INTRODUCTION



**Read the instruction manual carefully before starting the machine.**

### 1.1 STRUCTURE OF THE MANUAL

This manual is made up of the cover, the table of contents, a section containing all the figures and explanatory text.

Contents are divided into chapters, headings and subheadings.

This manual contains a number of tables relative to the different engines (if scheduled).

To facilitate reading, highlight the data which applies to your machine/engine.

#### Figures

The figures in these instructions for use are numbered 1, 2, 3, etc.

Components shown in the figures are marked A, B, C, etc.

A reference to a figure is written (2).

A reference to component A in figure 2 is written (2:A).

#### Headings

The headings in these instructions for use are numbered in accordance with the following example:

2.3 INTENDED USE" is a subheading to "2 GETTING TO KNOW THE MACHINE" and is included under this heading.

When referring to headings, usually only the relative number is specified, e.g. "See 2.3.1".

### 1.2 SYMBOLS



**WARNING symbol. Failure to observe the instructions provided may result in serious injury and/or material damage.**



**MANDATORY symbol. Used to indicate that an operation is mandatory.**



**PROHIBITION symbol. Used to indicate that an operation is prohibited.**



**NOTE symbol. Indicates information or details which are particularly important**



**REFERENCE symbol. Indicates a reference to information, the note alongside indicates where the information can be found.**

### 1.3 TAKING CARE OF THE MANUAL

Keep the manual in good, legible condition, in a place which is known and easily accessible to the machine user.

## 2 GETTING TO KNOW THE MACHINE

The machine described herein is gardening equipment, a ride-on lawnmower to be precise, with front cutting.

The machine is fitted with an engine which activates the cutting means assembly, protected by a safety guard, as well as a drive unit which moves the machine.

The machine is articulated. This means that the frame is divided into a front section and a rear section which can be steered in relation to one another.

The articulated steering allows the machine to turn smoothly round trees and other obstacles with a very tight turning radius.

The operator can drive the machine and activate the main commands from a sitting position in the driver's seat.

The safety devices installed on the machine stop the engine and the cutting means assembly.

### 2.1 MODELS [2WD]

This machine is rear wheel drive.

The rear axle is equipped with a hydrostatic transmission with infinitely variable forward and reverse gear ratios.

The rear axle is also equipped with a differential to facilitate turning.

Front mounted accessories are activated by drive belts.

### 2.2 MODELS [4WD]

This machine has 4-wheel drive.

The power from the engine to the drive wheels is transferred hydraulically.

The engine activates an oil pump which, via a hydraulic circuit, activates the rear and front axles (wheels).

The front and rear wheels rotate at the same speed.

Both axles are equipped with a differential to make turning easier.

Front mounted accessories are activated by drive belts.

## 2.3 INTENDED USE

This machine has been designed and built to mow grass.

The use of special accessories, envisaged by the Manufacturer as original equipment or purchasable separately, allows the user to perform this work in accordance with different operating modes as illustrated in this manual or the instructions accompanying the individual accessories.

Likewise, the possibility to apply supplementary equipment (if envisaged by the Manufacturer) may extend the range of intended uses to other functions, in accordance with the limits and conditions indicated in the instructions accompanying the equipment in question.



**The machine must be used by one operator.**



**The stability of the machine is reduced when a front attachment other than the cutting means assembly is used.**



**The machine must be used with at least the cutting means assembly or another front attachment installed.**

### 2.3.1 DEFINITION OF THE TYPE OF USER

This machine is designed for use by the general public, i.e. non-professional operators.

This machine is intended for "hobby use".

## 2.4 IMPROPER USE

Any other use, different to the uses cited above, may be dangerous and cause injury and/or material damage.

Improper uses (by way of example and not limited to) are:

- Carrying other people, children or animals on the machine or on a trailer.
- Towing or pushing loads without using the proper towing attachment.
- Using the machine to travel over unstable, slippery, frozen, pebbly or potholed terrain or puddles or marshes which do not allow the user to accurately assess the solidity of the ground.
- activation of the cutting means on grass-free areas.



**Improper use will render the warranty null and void and the Manufacturer shall be exonerated from all liability, with all responsibility for damages or injuries to self or third parties being transferred to the user.**

## 2.5 SAFETY SIGNS

Safety signs on the machine are designed to inform the user as to the correct conduct to be maintained when using the machine, in particular for operations which require special caution and attention.



**WARNING! Indicates a hazard. It is usually accompanied by other symbols indicating the type of hazard.**



Warning! Read the instruction manual before using the machine.



Warning! Watch out for any loose objects on the ground. Pay attention to any other people who may be in the area.



Warning! Always wear hearing protectors.



Warning! The machine has not been approved for use on public roads.



Warning! The machine, equipped with original accessories, must not be driven in any direction on slopes with a gradient greater than 10°.



Tyre pressure. The decal shows the optimum tyre pressure values - see cap. "0 TECHNICAL DATA TABLE". Correct tyre pressure is an essential condition for achieving the best performance from your machine.

### 2.5.1 Decals (4)



Indicates parking brake blocking.



Indicates transmission engaging / release (4:A).

The decal is located:

- near the transmission engage/release lever.



Indication of the maximum towable weight (4:B).

The decal is located:

- near the tow bar.



Warning! Burns hazard (4:C). Do not touch the silencer.

The decal is located:

- near the exhaust pipe.



Warning! Risk of crushing injuries (4:D). Keep hands and feet well away from the articulated steering joint and the towing hook when it is connected to an attachment.

The decal is located:

- near the articulated steering joint;
- near the tow bar.



**Any damaged or illegible decals must be replaced.**



**Order replacement decals from an authorised assistance centre.**

## 2.6 PRODUCT IDENTIFICATION LABEL

The identification label holds the following data (see fig. 1):

1. Manufacturer's address
2. Type of machine
3. Sound power level
4. CE conformity marking
5. Weight in Kg
6. Engine operating speed and power
7. Year of manufacture
8. Serial number
9. Article code



Write your machine's serial number in the space provided in the figure (1:10).

The identity of the product is determined by two parts:

- The machine's item and serial numbers:
- The engine's model, type and serial numbers:



**Use these means of identification whenever you contact an authorized service workshop.**



**The example of the declaration of conformity can be found on the second to last page of this manual.**

## 2.7 MAIN COMPONENTS

The machine is made up of the following main components (see fig. 1):

- A. Chassis
- B. Wheels
- C. Steering wheel
- D. Seat
- E. Console
- F. Control pedals
- G. Bonnet

- H. Front accessories lift lever
- I. Fuse box
- J. Battery
- K. Fuel tank
- L. Transmission fluid reservoir
- M. Engine
- N. Quick-release supports for accessories

## 3 SAFETY REGULATIONS



**Read these instructions carefully before using the machine.**

### 3.1 TRAINING



**CAUTION! Read these instructions carefully before using the machine.**

**Be familiar with the controls and the proper use of the machine.**

**Learn to stop the machine and disengage the controls quickly.**

**Failure to observe the warnings and instructions may lead to electric shock, fire and/or serious injury.**

**Please keep all the warnings and instructions for future reference.**



**Never allow children or people unfamiliar with these instructions to use the machine.**

**Local regulations may restrict the age of the operator.**



**Never use the machine when bystanders, especially children, or pets are in the surroundings.**



**Never use the machine if the user is tired or unwell, or has taken medicine, drugs, alcohol or substances which may slow his reflexes and compromise his judgement.**



**Keep in mind that the operator or user is responsible for accidents or hazards occurring to other people or their property.**

**It is the user's responsibility to assess the potential risk of the area where work is to be carried out, and to take all the necessary precautions to ensure his own safety and that of others, particularly on slopes or rough, slippery and unstable ground.**





**In the event of changes in ownership or loan of the machine, make sure the future user reads the instructions for use provided in this manual.**



**Never carry children or other passengers on the machine: they might fall off and be seriously injured or inhibit safe use of the machine.**



**The operator of a machine must carefully follow the driving instructions, particularly:**

- a. the need for care and concentration when using machines;
- b. that control of a machine sliding on a slope will not be regained by the application of the brake. The main cause behind a loss of machine control are:
  - insufficient wheel grip;
  - being driven too fast;
  - inadequate braking;
  - the type of machine is unsuitable for its task;
  - lack of awareness of the effect of ground conditions, especially slopes;
  - Incorrect use of the machine as a towing vehicle;



**The machine is equipped with a series of safety microswitches and devices which must never be removed, altered or tampered with. Removing these devices invalidates the warranty and the manufacturer declines any responsibility. Always check the safety devices work before using the machine.**

### 3.2 PREPARATION

- When using the machine always wear sturdy, slip-resistant footwear and long trousers.
- Never activate the machine when barefoot or wearing open-toe sandals.
- Do not wear chains, bracelets, cumbersome clothing with strings or ties.
- Tie back long hair. Always wear hearing protectors.
- Thoroughly inspect the area where the equipment is to be used and remove all objects which may be thrown by the machine (stones, sticks, metal wire, bones, etc.)



**CAUTION: DANGER! The fuel is highly flammable.**

- a. store fuel in containers specifically designed for this purpose;
- b. refuel using a funnel and outdoors only. Do not smoke while refuelling or whenever handling the fuel;
- c. Add fuel before starting the engine. Never remove the cap of the fuel tank or add fuel while the engine is running or when the engine is hot;
- d. If fuel is spilled, do not attempt to start the engine but move the machine away from the area of spillage and avoid creating any source of ignition until the fuel has evaporated and the fumes dispersed;
- e. Always replace caps of fuel tanks and container securely.



**Replace faulty silencers.**



**Before using, always carry out a visual inspection, particularly of the cutting means, seeing that the screws and cutting means are not worn or damaged. Replace a worn or damaged cutting means and screws as a set to preserve balance.**

**Any repair shall be performed by an authorized service centre.**



**Check the condition of the battery at frequent intervals. Replace if damages to the casing, cover or terminals are found.**

### 3.3 DURING OPERATION



**Never start the engine in a confined area where hazardous carbon monoxide gases can build up.**

**All starting operations have to be effected in an open or well ventilated area!**

**Always remember that exhaust gases are toxic!**



**Mow only in daylight or with good artificial light in good visibility conditions. Keep persons, children and animals away from the working area.**



**If possible, avoid mowing wet grass. Avoid working in the rain and when there is a thunderstorm risk. Do not use the machine in bad weather, especially if there is a risk of lightning.**



**Before starting the engine, disengage the cutting means or the PTO and put the gear into neutral.**



**Take special care when approaching obstacles which may obscure your vision.**



**Apply the parking brake when you park the machine.**



**The machine may not be driven on slopes greater than 10° (17%), in any direction.**



**Remember there is no such thing as a "safe" slope. Travel on grass slopes requires particular care. To avoid roll-over of losing control of the machine:**

- do not stop or start suddenly when going up or downhill;
- engage the drive slowly and always keep the machine in gear, especially when travelling downhill;
- machine speeds should be kept low on slopes and during tight turns;
- Beware of humps, hollows and other hidden dangers;
- Never mow across the face of the slope. When mowing on a slope, proceed up and down the slope as opposed to across it, taking great care when changing direction that the first wheels do not hit obstacles (such as stones, branches, roots, etc.), that may cause the machine to slide sideways, roll over or otherwise cause loss of control.



**Reduce speed before any change of direction on slopes and always engage the parking brake before leaving the machine stopped and unattended.**



**exercise caution in the proximity of cliffs, ditches or embankments. The machine may overturn if a wheel drives over the edge or the edge gives way.**



**Exercise maximum caution when reversing and working in reverse. Look behind you both before and during reversing to make sure there are no obstacles.**



**Use care when pulling loads or using heavy equipment:**

- use only approved drawbar hitch points;
- limit loads to those you can safely control;
- Do not make any sudden turns. Use care when reversing;
- use counterweight(s) or wheel weights whenever advised in the instructions manual.



**Disengage the cutting means or PTO and lift the cutting means assembly to its highest position when crossing grass-free areas or when moving from one area to another.**



**Look out for traffic when using the machine near the road.**



**CAUTION! The machine has not been approved for use on public roads. It has to be used (as indicated by the highway code) in private areas closed to traffic.**



**Never use the machine if the safeguards are damaged.**



**Do not put hands or feet near or under rotating parts. Keep clear of the discharge opening at all times.**



**Do not leave the machine on high grass with the engine running to avoid the risk of starting a fire.**



**When using accessories, always direct the discharge chute away from people.**



**Only use accessories approved by the machine manufacturer.**



**Do not use the machine if the accessories/tools are not installed in the correct places. Driving without accessories may adversely effect machine stability.**



**Take care when using grass collectors and other accessories which may alter machine stability, especially when working on a slope.**



**Do not change the engine governor settings or overspeed the engine.**



**Do not touch engine components which get hot during use. Burns hazard.**



Disengage the cutting means or the PTO, set the engine to the idle position, stop the engine and remove the key (make sure that all moving parts have come to a complete stop):

- a. whenever you leave the machine unattended or leave the driver's seat.
- b. before removing the jamming cause or unclogging the collector channel;
- c. before checking, cleaning or working on machine;
- d. after striking a foreign object. Inspect the machine for damage and make repairs before restarting and operating the machine;



Disengage the cutting means or the PTO and stop the engine (make sure that all moving parts have come to a complete stop):

- a. Before refuelling;
- b. Every time you remove the grass collector sack or put it back on;
- c. adjusting the cutting height, assuming this operation cannot be done from the driver's seat.



Disengage the cutting means or the PTO during transport or whenever the machine is not being used.



Reduce the throttle setting before stopping the engine. turn the fuel off at the conclusion of mowing, following the instructions in the manual.



Take care with multiple cutting means as one rotating cutting mean may cause other cutting means to rotate.



**WARNING** - In the event of failures or accidents when working with the machine, stop the engine immediately and move the machine away to avoid causing further damage; in the event of accidents with injuries to operators or third parties, take the first aid measures which are most appropriate to deal with the situation and contact a health care facility for the necessary treatment. Carefully remove any debris which could cause damage or injury to persons or animals if ignored.



**CAUTION!** The noise and vibration levels shown in these instructions are the maximum levels for use of the machine.

The use of an unbalanced cutting means, the excessive speed of movement, or the absence of maintenance have a significant influence on noise emissions and vibrations. Consequently, it is necessary to take preventive steps to eliminate possible damage due to high levels of noise and stress from vibration. Maintain the machine well, wear ear protection devices, and take breaks while working.

### 3.4 MAINTENANCE AND STORAGE



**CAUTION!** - Before cleaning or doing maintenance work, take out the ignition key and read the relevant instructions. Wear adequate clothing and work gloves whenever your hands are at risk.



**CAUTION!** - Never use the machine with worn or damaged parts. Faulty or worn-out parts must always be replaced and never repaired. Only use original spare parts: The use of non-original and/or incorrectly fitted parts will compromise the safety of the machine, may cause accidents or personal injuries for which the Manufacturer is under no circumstance liable or responsible.



Any regulations and maintenance operations not described herein must be carried out by your Dealer or Authorized Service Centre, which have the necessary knowledge and equipment to ensure that the work is carried out correctly, maintaining the correct degree of safety and the original operating conditions of the machine. Any adjustments or maintenance operations carried out by people not having the necessary knowledge will nullify the warranty and exonerate the manufacturer from all liability.

- After each use of the machine, remove the key and check for any damage.
- Keep all nuts, bolts and screws tight to be sure the equipment is in safe working condition. Regular maintenance is essential for safety and for maintaining performance levels.
- Regularly check that the **cutting means** screws are securely tightened.



Wear suitable work gloves when handling the cutting means assembly during removal and reinstallation operations.



Check the cutting means' balance after sharpening. All operations concerning the cutting means assembly (disassembling, sharpening, balancing, assembling and/or replacement) are tough works and require a specific knowledge as well as special tools; for sake of safety, they should always be performed by an authorized service centre.

- Regularly check the brakes work properly. It is important to service the brakes and repair them if necessary.
- Replace any damaged warning and instruction stickers.
- If the machine has no mechanical stoppers for transport, accessories must always be resting on the ground when the machine is parked, stored or left unattended.
- Store the machine where children cannot get to it.



Never store the equipment with fuel in the tank inside a building where fumes may reach a flame or a spark or a source of extreme heat.

- Allow the engine to cool before storing in an enclosed space.
- To reduce the fire hazard, keep the engine, exhaust silencer, battery compartment and fuel storage area free of grass, leaves, or excessive grease.
- To reduce the risk of fire, regularly check the machine for oil and/or fuel leaks.
- If the fuel tank has to be drained, this should be done outdoors and when the engine is cool.
- The ignition key must never be left inserted in the machine, or where children or persons not familiar to the machine may reach it. Before any maintenance or repair, remove the ignition key.



**CAUTION! – Battery acid is corrosive. In the event of mechanical damage or overcharging, acid may leak out. Avoid inhalation or contact with any part of the body.**



Inhaled acid fumes are harmful to mucous membranes and other internal organs. Seek medical attention immediately.



**CAUTION! – Do not overcharge the battery. Excessive charging may cause the battery to explode with subsequent acid leaks.**



**CAUTION! – Acid can seriously damage tools, clothing and other materials. Rinse away spilled acid immediately with water.**



**Do not short circuit the battery terminals. Sparks occur which can result in fire.**



**TAKE CARE over the hydraulic components. Pressurized hydraulic fluid leaks may lead to injection injuries which can seriously damage tissues and need immediate medical attention.**

### 3.5 TRANSPORTING



**CAUTION! - If the machine is transported on a truck or trailer, use ramps with suitable resistance, width and length. During transport, close the fuel stopcock (if fitted), lower the cutting means assembly or the attachment, engage the parking brake and fasten the machine securely with ropes or chains to the hauling device.**

### 3.6 ENVIRONMENTAL PROTECTION

- Safeguarding the environment must be a relevant and priority aspect of machine use, of benefit to the community and the environment we live in. Avoid being a disturbance to the neighbourhood.
- Adhere strictly to the local regulations governing the disposal of packaging, oil, fuel, filters, damaged parts or any other element which may have an impact on the environment; this waste should not be disposed of along with standard household waste, but must be disposed of separately and sent to special waste disposal facilities for handling and recycling.
- Adhere strictly to local regulations governing the disposal of cuttings.
- When the machine is withdrawn from service, do not dump it in the environment, but take it to

a waste disposal facility in accordance with the local regulations in force.

## 4 INSURING YOUR LAWMOWER

Check the insurance on your lawnmower.  
Contact your insurance company.

You ought to have fully comprehensive insurance for traffic, fire, damage and theft.

## 5 ASSEMBLY



**The battery must be fully charged before being used for the first time.**



**Do not use the machine until all the indications provided in the "ASSEMBLY" section have been carried out.**



**Unpacking and completing the assembly should be done on a flat and stable surface, with enough space for machine handling and its packaging, always making use of suitable equipment.**

### 5.1 ASSEMBLY COMPONENTS (3)

The machine is delivered with the seat, armrests, steering wheel, tow bar, quick-fit supports dismantled. The battery is in its housing but not connected.

The packaging holds the components needed for assembly (3) as listed in the table below:

Pos.	No.	Description	Dimensions
A	2	Pin	6 x 36
B	1	Shim	6x38x0.5
C	1	Shim	16x38x1.0
D	2	Ignition key	/
E	2	Screw for battery	/
F	2	Nut for battery	/
G	2	Nut	M8
H	1	Tow bar	/
J	2	Screw	8x20
R	4	Split lock washer	14 x 8,2 x 2

### 5.2 BONNET(5:A)



Open the bonnet to access the fuel cock, battery and engine.

The bonnet can be opened as follows:

1. Undo the rubber strap (5:B) on the front edge

of the bonnet

2. Lift the bonnet with care. To close the bonnet lower it and do up the strap to secure it.



**It is prohibited to start the engine when the bonnet is open.**

### 5.3 BATTERY

For the type of battery installed on the machine, please refer to "0 TECHNICAL DATA TABLE"



**CAUTION! Battery acid is corrosive and contact with it is harmful. Handle the battery with care taking care not to let acid leak out.**



**Do not check or top up the battery fluid.**

#### 5.3.1 Battery connection (6)

Connect the battery to the machine's electrical system using the relative screws and nuts (6:F; 6:E):

1. Connect the red cable to the battery's positive terminal (+).
2. Connect the black cable to the battery's negative terminal (-).



**If the leads are disconnected/connected in the wrong order, there is a risk of a short-circuit and damage to the battery.**



**Inverting the cable connections will damage the alternator and the battery.**



**Tighten the cables securely. Loose cables can cause a fire.**



**The engine must never be driven with the battery disconnected. There is a risk of serious damage to the alternator and the electrical system.**

#### 5.3.2 Battery charging



**The battery must be fully charged before being used for the first time.**



**Please refer to 9.10 for the battery charging procedure.**

### 5.4 SEAT (7)

1. Remove the following components from the seat bracket:
  - 4 Nuts (for blocking during transport, not

used).

- 4 Screws (7:K).
  - 4 Shoulder washers (7:L).
  - 4 Split lock washer (7:R).
2. Position the seat on the seat bracket mounting.
  3. Put the shoulder washers (7:L) on the screws (7:K), complete with washers (7:R).
  4. Insert the screws, complete with shoulder washers, in the slots in the seat bracket and the holes in the seat plate. Screw the seat into place.

Tightening torque:  $9 \pm 1.7$  Nm.



**Tightening the screws to a torque over  $9 \pm 1.7$  Nm, will damaged the seat.**

5. Check that the seat moves easily in the slots in the bracket.

The seat can be folded. If the machine is parked outside where it is exposed to rain, fold the seat forward to protect the seat cushion from getting wet.

### 5.5 STEERING WHEEL (8)

In order to minimise axial play in the steering column, place the 0.5-mm and/or 1-mm shim/s (3:C; 3:B) on the steering column between the sleeves, pos. (8:A) as follows:

1. Install the sleeve (8:B) on the steering column and secure in place by inserting one of the pins (8:C) by approximately 1/3 of its length.
2. Pull the sleeve and steering column upwards.
3. Check that the 0.5-mm shim, the 1.0-mm shim (or both) can be inserted into the gap which is created in point (8:A).. The shim/s must not be forced in, as there must be a little axial play.
4. Remove the pin (8:C) using a pin punch (8:D) and remove the sleeve.
5. Install the shim/s as indicated in point 3 above.
6. Install the sleeve on the steering column and secure by inserting both pins completely. Block the steering column.

### 5.6 TOW BAR (9)

Install the tow bar (9:B) on the rear of the machine. Use the screws and nuts (9:A; 9:C).

Tightening torque: 22 Nm.

### 5.7 QUICK-RELEASE SUPPORTS (1:N)

The quick-release supports and relative installation instructions are supplied in a separate box inside the machine packaging.

Install the quick-release supports on the machine's front axles.

### 5.8 TYRE PRESSURE

For the tyre pressure, please refer to chap. "0 TECHNICAL DATA TABLE".

### 5.9 ATTACHMENTS

For installation of attachment, see the installation guide accompanying each attachment.



**Note: In this case the cutting means assembly is considered an attachment.**

## 6 CONTROLS

### 6.1 MECHANICAL ATTACHMENT LIFT PEDAL (10:C)

The control lever (10:C1) is used to take the accessories from the operating position to the transport position.

- Transport position: press the pedal right down then lift your foot off: the pedal stays down.
- Working position: press and slowly release the pedal.



**Do not attempt to switch to the transport position while the hooked-up attachment is in operation. This will destroy the drive belt.**

### 6.2 PARKING BRAKE PEDAL (10:B)



**Never press the pedal while driving.**

**There is a risk of overheating the power transmission.**

The pedal (10:B) has the following positions:

 Released: Traction is engaged. The parking brake is not activated.

Pressed to halfway: Forward drive disengaged. The parking brake is not activated.

Pressed right down. Drive disengaged. The parking brake is fully activated but not locked. This position is also used as an emergency brake.

### 6.3 PARKING BRAKE LOCKING LEVER (10:A)

 The lever locks the “brake” pedal in the pressed right down position. This function is used to lock the machine on slopes, during transport, etc., when the engine is not running.

#### Locking:

1. Press the pedal (10:B) right down.
2. Move the locking lever (10:A) to the right.
3. Release the pedal (10:B).
4. Release the locking lever (10:A).



#### Unlocking:

1. Press and release the pedal (10:B).

### 6.4 TRACTION PEDAL (10:F)

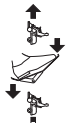
The pedal determines the gearing ratio between the engine and the drive wheels (= the speed). When the pedal is released, the service brake is activated.



-  - Press the pedal forward – the machine moves forward.
-  - No load on the pedal – the machine is stationary.
-  - Press the pedal backward – the machine reverses.

- Reduce the pressure on the pedal – the machine brakes.

A plate is installed on the upper section of the pedal which can be adjusted to suit the driver's foot.



**If the machine does not brake as expected when the pedal is released, the left pedal (10:B) should be used as an emergency brake.**

### 6.5 STEERING WHEEL (10:D)

The height of the steering wheel is fully adjustable. Unscrew the adjustment knob (10:E) on the steering column and raise or lower the steering wheel accordingly. Tighten.



**Do not adjust the steering wheel when the machine is running.**



**Never turn the steering wheel when the machine is stationary with a lowered attachment. There is a risk of abnormal loads on the servo and steering mechanisms.**

### 6.6 THROTTLE AND CHOKE CONTROL [B&S Power Built] [B&S Intek] (if provided) (11:A)

A control for regulating the engine speed and using the choke when starting the engine in cold conditions.



**If the engine runs unevenly (alternate variation in the number of engine revs) the control may be too far forward, thus activating the choke. This damages the engine, increases fuel consumption and is harmful to the environment.**



Choke – for starting the engine in cold conditions. Do not use this position when the engine is warm.



Full throttle – should always be used when the machine is in use. The full throttle position is approximately 2 cm behind the choke position.



Idling.



**Some models are equipped with a system that automatically controls the choke position in the carburettor during engine ignition and heating.**

### 6.7 THROTTLE CONTROL (ACCELERATOR) (12:A) MOD.: [B&S Vanguard]

Control for regulating engine running speed.



Full throttle – should always be used when the machine is in use.



Idling.



**Some models are equipped with a system that automatically controls the choke position in the carburettor during engine ignition and heating.**

### 6.8 CHOKE CONTROL (if provided) (12:B) - MOD.: [2WD]

A choke control to be used when starting the engine in cold conditions.



Control fully pulled out (12:B1) - butterfly closed. For starting the machine in cold conditions.

Control pushed in (12:B2) - butterfly open. For

starting the engine in warm conditions and during operation.

 **Do not use the choke when the engine is warm.**

 **Some models are equipped with a system that automatically controls the choke position in the carburettor during engine ignition and heating.**

### 6.9 IGNITION /HEADLIGHT BLOCK (11:C; 12:C)

The ignition block is used for starting and stopping the engine.

It is also used to switch on the headlight.

 **Do not leave the ignition key in position 2 or 3 when you leave the driving seat. There is a risk of fire (fuel can run into the engine through the carburettor) and the battery may go flat and get damaged.**

The four ignition key positions:

 1. Stop position – the engine is short-circuited. The key can be removed.

 2. Operating position – headlight activated.

 3. Operating position – headlight not activated.

 4. Start position – the electric starter motor is activated when the key is turned to this position. Once the engine has started, let go of the key which will return to the driving position 3. Turn the key to position 2 to light the headlight.

### 6.10 POWER TAKE-OFF (11:D; 12:D)

A lever for engaging and disengaging the power take-off for operating front-mounted accessories.

 **The PTO must never be engaged when the front attachment lift is in the transport position. This will destroy the belt drive.**

 Lever forward – PTO disengaged.

 Lever back – PTO engaged.

### 6.11 HOUR METER (13:A)

Indicates the number of service hours completed. Only works when the engine is running.

### 6.12 CUTTING HEIGHT ADJUSTMENT (11:E; 12:E)

The machine is equipped with a control for using the cutting means with electrical cutting height adjustment.



The switch allows the user to continuously adjust the cutting height.

The **cutting means** are connected to the contact (13:B).

### 6.13 TRANSMISSION ENGAGE/DISENGAGE LEVER (14; 15)

A lever for disengaging the variable transmission.



2WD is equipped with a lever, connected to the rear axle. See (14:A).

4WD is equipped with two levers, connected to the rear axle (15:A) and the front axle (15:B).



**The engagement/release lever must never be between the outer and inner positions. This overheats and damages the transmission.**

The levers allow the user to move the machine manually (pushing or pulling), without the engine running.

The two positions are:

Transmission engaged (14:A1; 15:A1-B1) - transmission engaged for normal operation.

Transmission disengaged (14:A2; 15:A2-B2) - transmission disengaged. The machine can be moved by hand.

The machine must not be towed over long distances or at high speeds. The transmission could get damaged.



**Do not activate the machine with the transmission disengaged (lever in). Risk of damage and oil leakage in the front axle.**

### 6.14 SEAT ADJUSTMENT (16:B)



The seat can be moved backwards and forwards to suit the driver as indicated below:

1. Move the control lever (16:A) upwards.
2. Set the seat to the desired position.



3. Release the control lever (16:A) to lock the seat.

The seat is equipped with a safety switch that is connected to the machine's safety system.

This means that when no-one is sitting in the seat the machine cannot be started. (see 7.6.2).

### 6.15 BONNET



See 5.2 for how to access the fuel cock, battery and engine.

### 6.16 QUICK-RELEASE SUPPORTS



These support allows the user to swap from one attachment to another quickly and easily.

The quick-release supports allow the user to move the cutting means assembly quickly and easily between two positions, i.e.:

- Normal position with the belt fully tensioned.
- Positioned 4 cm behind the normal position, with the belt slackened, so that the cutting means assembly moves closer to the base of the machine.

Being as the belt tensioner is released from the belt, the quick-release supports simplify belt and cutting means assembly replacement, and also make shifting to the washing position and service positions easier.

#### Belt tension releasing (17; 18)



See also the instructions provided with the attachment and with the quick-release support.

1. Remove the cotter pins or lock pins (17:C) from both sides.
2. Open the quick-release supports by pressing on their rear sections with your heel (17:A)



Once the quick-release supports have been opened, the arms of the attachment are free and no longer secured to the hook-up device.



For any adjustment or maintenance operation, replace the arms on the support and reclose.

1. Carry out the necessary corrective action, e.g.:
  - Release the belt.
  - Replace the attachment by unhooking the arms (19).

#### Tensioning the belt (17; 18)

First tension one side and then the other accor-

ding to the instructions provided below.



**Do not turn the lever using your hands. Risk of crushing injuries.**

1. Place your foot on the lever (18:A) and carefully turn it 180° forwards.
2. Install the cotter pin or lock pin (17:C).
3. Repeat the operation on the other side.

## 7 START-UP AND OPERATION

### 7.1 PRECAUTIONS FOR USE



**Always make sure the engine oil level is correct. This is particularly important when operating on slopes (see 7.4).**

**Pay attention when mowing on slopes: avoid abrupt starts and stops, do not run the machine transversally to the slope but run from top to bottom and vice versa.**

**Apply the parking brake when you park the machine.**



**The machine may not be driven on slopes greater than 10° in any direction.**



**Reduce the speed on slopes and when making sharp turns in order to retain control of the machine and reduce the risk of overturning.**



**Do not turn the steering wheel to full lock when driving at full speed. The machine may overturn.**



**Keep hands and feet well away from the articulated steering joint and seat bracket. Risk of crushing injuries.**

### 7.2 COMBINED USE OF ACCESSORIES



For the combined use of accessories, please refer to the "TABLE FOR THE CORRECT COMBINATION OF ACCESSORIES" in section "0 TECHNICAL DATA TABLE"

### 7.3 REFUELLING



**Always use lead-free petrol only. DO NOT mix petrol with oil.**

For the capacity of the fuel tank, please refer to "0 TECHNICAL DATA TABLE". The transparency of the tank allows the user to check the level easily.



**NOTE! Petrol is perishable and should not remain in the tank for more than 30 days.**

It is possible to use ecological fuels, i.e. alkylate petrol. The composition of these petrols is less harmful to people and the environment.

No negative effects linked to use of the same have been reported. However, there are types of alkylate-based petrol available on the market

for which it is not possible to give precise indications regarding their use.

For further information it is advisable to consult the instructions and data provided by the producer of the alkylate-based petrol.

Never fill the tank right to the top.

Leave a little space (equal to at least the whole depth of the top-up mouth + 1 - 2 cm from the top of the tank) so that when the petrol heats up it has room to expand without overflowing.



**If you plan on putting the machine away for a prolonged period (e.g. over the winter), only put enough fuel in the tank to finish the last job in hand.**

**In fact, before storing the machine it is a good idea to empty the fuel tank completely (see 10).**

### 7.4 CHECKING THE ENGINE OIL LEVEL (21; 22)

The machine is delivered complete with engine oil.



**Before starting the machine check the level of the engine oil.**



**To check / top up the engine oil, see 9.5.1.**

### 7.5 CHECKING THE TRANSMISSION FLUID LEVEL



**To check / top up the transmission fluid, see 9.7.1.**

### 7.6 SAFETY CHECKS

When trying out the machine, check that the results of the safety checks correspond with the indications provided in the following tables.



**Always carry out the safety checks before use.**



**If any of the results fails to match the indications provided in the following table, do not use the machine!**

**Take it to a service centre to be checked and repaired if necessary.**

7.6.1 General safety check

Object	Result
Fuel lines and connections.	No leaks.
Electrical cables	All insulation intact. No mechanical damage.
Exhaust system.	No leaks at connections. All screws tightened.
Oil lines	No leaks. No damage.
Drive the machine forwards/backwards and release the driving pedal.	The machine will stop.
Test driving	No abnormal vibrations. No abnormal sound.

7.6.2 Electrical safety check

Status	Action	Result
The parking brake pedal is not pressed.	Try to start the machine.	The engine will not start.
Engine running.	The driver gets up from the seat.	The engine is switched off.

7.7 START-UP / OPERATION

 **When using the machine, the bonnet must be closed and fastened shut.**

 **Always use full throttle when using the machine.**

 **When starting the machine, wait for 2 seconds in starting position before starting the engine.**

1. Open the fuel cock (24).
2. Check that the spark plug cables are installed on the spark plugs.
3. Check the PTO is disengaged (11:D; 12:D).
4. Do not keep your foot on the service/drive brake (10:F)

**Models [B&S Power Built] [B&S Intek]:**

**Cold start**

1. Engage the transmission (14:A1)
2. Activate the parking brake (10:B)
3. Put the choke on (11:A).
4. Turn the key in the ignition and start the engine.
5. When the engine is running, gradually accelerate to maximum operating speed (11:A).

 **Before starting work with the machine, wait a few minutes for the oil to warm up.**

**Warm start.**

1. Engage the transmission (14:A1)
2. Activate the parking brake (10:B)
3. Turn the throttle to full on (11:A)
4. Turn the key in the ignition and start the engine.

 **To proceed see the instructions provided in heading 7.7.1.**

**Models [B&S Vanguard]:**

**Cold start**

1. Engage the transmission (15:A1; 15:B1)
2. Activate the parking brake (10:B)
3. Turn the throttle to full on (12:A)
4. Pull the choke out completely (12:B1).
5. Turn the key in the ignition and start the engine.

 **Before starting work with the machine, wait a few minutes for the oil to warm up.**

**Warm start.**

1. Engage the transmission (15:A1-B1)
2. Activate the parking brake (10:B)
3. Turn the throttle to full on (12:A)
4. The choke must be pressed in (12:B2).
5. Turn the key in the ignition and start the engine.

 **To proceed see the instructions provided in heading 7.7.1.**

**7.7.1 Operation**

To operate with the machine proceed as described below:

- Press the pedal (10:B) right down then release it.
- Activate the pedal (10:F) to move the machine.
- Go to the work area.
- If front accessories have been installed, activate the PTO (11:D, 12:D).
- Commence work.

**7.8 STOPPING**

To stop the machine, proceed as follows:

- Disengage the PTO (11:D; 12:D).
- Engage the parking brake (10:B)
- Allow the engine to idle 1-2 mins.
- Turn off the engine by turning the ignition key.

- Close the fuel cock. This is particularly important if the machine is to be transported on a trailer for example.



**If you have to leave the machine unattended, disconnect the spark plugs and remove the key from the ignition.**



**The engine may be very warm immediately after it is shut off. Do not touch the silencer, cylinder or cooling fins. This can cause burn injuries.**

## 7.9 CLEANING



**To reduce the risk of fire, keep the engine, silencer, battery and fuel tank free from grass, leaves and oil**

**To reduce the risk of fire, regularly check the machine for oil and/or fuel leaks.**



**Never use high-pressure water jets. This can damage shaft seals, electrical components or hydraulic valves.**

Always clean the machine after use. To clean the machine adhere to the instructions provided below:

- Do not spray water directly onto the engine.
- Clean the engine with a brush and/or compressed air.
- Clean the motor cooling air intake.
- After cleaning using water, start the machine and any cutting means assembly to remove any water which may otherwise end up in the bearings and cause damage.

## 8 USING THE ATTACHMENT



**Make sure the grass to be cut is completely free of foreign objects such as stones etc.**

### 8.1 CUTTING HEIGHT

For best results, cut off the top third of the grass. See fig. 23.

If the grass is long and needs cutting back significantly, cut twice using two different cutting heights.

Do not use the lowest cutting heights if the lawn surface is uneven.

This would entail a risk of the cutting means being

damaged against the surface and the lawn's top layer of soil being removed.

### 8.2 MOWING TIPS

To get the best mowing results, follow the tips given below.

- Cut grass frequently.
- Run the machine at full revs.
- Grass should not be wet.
- Only use sharp cutting means.
- Keep the bottom side of the cutting means clean.

## 9 MAINTENANCE

### 9.1 ASSISTANCE PROGRAMME

To keep the machine in good condition as regards reliability, operational safety and attention to the environment, always comply with the STIGA SpA assistance programme.

Details on this programme's interventions are illustrated in the attached STIGA SpA maintenance manual.

The Basic Service must always be carried out by an authorized service workshop.

The First Service and Intermediate Service should be carried out by an authorized service workshop, but can also be carried out by the user.

The procedures are indicated in the handbook and are described in the chapter "7 START-UP AND OPERATION" as well as here below.

The checks carried out by an authorized service workshop guarantee professional workmanship and the use of genuine spare parts.

The handbook is stamped every time a Basic Service is performed and each time an Intermediate Service is carried out by an authorized service workshop. A handbook with these stamps increases the second-hand value of the machine.

### 9.2 PREPARATION



**All service and all maintenance checks must be carried out on a stationary machine with the engine switched off.**



**Always apply the parking brake to stop the machine from moving.**



**Stop the engine.**

 Prevent inadvertent start-up of the engine by disconnecting the spark plug cables and removing the ignition key.

### 9.3 MAINTENANCE TABLE

 See chapter "13 MAINTENANCE SUMMARY TABLE". The table is designed to help you keep your machine in efficient and safe working order. It indicates the main operations to be performed and the frequency of the same. Perform the relative operation described based on the first deadline to arrive.

 Change the oil more frequently if the engine has to work in difficult conditions or when the ambient temperature is high.

### 9.4 TYRE PRESSURE

Adjust the tyre pressure to meet the values provided in "0 TECHNICAL DATA TABLE".

### 9.5 ENGINE OIL TOP-UP/CHANGE

 For this maintenance operation, see also the manual for the engine supplied with the machine.

#### 9.5.1 Inspection / top-up (21; 22)

 Always check the fluid level before use. To check the level, make sure the machine is on even ground.

 Wipe around the dipstick. Unscrew it and pull it out. Wipe the dipstick clean.

**Push the dipstick down completely without screwing it into place. Now unscrew and pull the dipstick up again. Read off the oil level.**

**Top up if the level is lower than the "FULL" mark (21; 22).**

 The oil level must never exceed the "FULL" mark. This results in the engine overheating. If the oil level exceeds the "FULL" mark, the oil must be drained until the correct level is achieved.

Change the oil more frequently if the engine has to work in difficult conditions or when the ambient temperature is high.

#### 9.5.2 Oil change/filling (21; 22)

 For the frequency of this intervention see chapter 13.

 For the type of oil to use please refer to "0 TECHNICAL DATA TABLE".

**Use oil with no additives.**

Change the oil when the engine is warm.



**The oil may be very hot just after the engine has been switched off. Consequently allow the engine to cool down for a few minutes before proceeding to drain off the oil.**

Proceed as follows:

1. Place the machine on a flat surface.
2. Put the parking brake on.
3. Open the bonnet.
4. Grab the clamp on the oil drain hose. Use polygrip pliers or similar (21:A; 22:A).
5. Move the clamp 3-4 cm up the oil drain hose and pull out the plug.
6. Collect the oil in a suitable vessel.



**NOTE! Take care not to spill any oil on the drive belts.**

7. Hand the spent oil over to a disposal facility in accordance with local provisions.
8. Replace the oil drain plug and move the clamp back over the plug.
9. Clean up any spills.
10. Remove the dipstick and fill with fresh oil. For the quantities of oil required, please refer to "0 TECHNICAL DATA TABLE".
11. After filling up the oil, start the engine and leave it to idle for 30 seconds.
12. Check there are no oil leaks.
13. Stop the engine. Wait for 30 seconds and then check the oil level again as indicated in heading 9.5.1.

#### 9.5.3 Replacing the oil filter (if present)



**For this maintenance operation, see also the manual for the engine supplied with the machine.**



**For the frequency of this intervention see chapter 13.**

For this maintenance operation is recommended to contact an authorised assistance centre.

First drain the engine oil and insert the oil drain plug as described above. Then replace the oil filter as follows:

- Clean the area around the filter and

dismantle the filter.

- Smear the gasket on the new filter with oil.
- Install the filter. First screw in the filter so that the gasket comes into contact with the engine. Then screw in the filter a further 1/2-3/4 turn.
- Continue with point 7 in accordance with the indications provided in 9.5.2.

## 9.6 REPLACING THE FUEL FILTER (21:B, 22:B)



**For this maintenance operation, see also the manual for the engine supplied with the machine.**



**For the frequency of this intervention see chapter 13.**

Check for fuel leaks once the new filter has been installed.

## 9.7 CHECKING/TOPPING UP THE TRANSMISSION FLUID [4WD]



**For the frequency of this intervention see chapter 13.**



**For the type and quantities of fluid required, please refer to "0 TECHNICAL DATA TABLE".**

### 9.7.1 Check/top-up (25)

1. Place the machine on a flat surface.
2. Read the fluid level in the reservoir (25:A). The level should match the line.
3. Top up if necessary.

### 9.7.2 Change

#### Drain off the fluid

1. Run the machine at variable speeds for 10-20 minutes to heat up the transmission fluid.
2. Place the machine on a flat surface.
3. Put the parking brake on.
4. Take the disengagement levers to position A1 - B1 as illustrated in fig.(15:A; 15:B).
5. Place a container under the rear axle and another one under the front axle.
6. Open the bonnet and remove the plug on the fluid reservoir.



**Only a 3/8" square drive may be used for the oil plug. Other tools may damage the plug.**

7. Remove the fluid drain plug from the rear

axle (26:A).

8. Remove the 2 drain plugs on the front axle. Use a 12 mm tubular wrench. Allow the fluid in the front axle and pipes to drain out (27).
9. Check that the gaskets on the drain plugs of the front axle are intact (27). Replace the plugs. Tightening torque: 15-17 Nm.
10. Check that the gasket on the drain plug of the rear axle is intact (26:A). Replace the plug in the rear axle. Tighten the drain plug to a torque of 5 Nm.



**The drain plug might get damaged if it is tightened to a torque exceeding 5 Nm.**

11. Draw out the fluid from the deepest part of the reservoir using a fluid extractor (28).
12. Dispose of the oil according to local regulations.

#### Filling

1. Fill the fluid reservoir with fresh fluid.
2. Check that the rear axle's clutch release lever is disengaged.
3. Start the engine. When the engine is started, the front axle's clutch release lever automatically slides inwards.



**Never start the engine when the rear axle clutch release lever is engaged and the front axle clutch release lever is disengaged (15:A; 15:B). This could damage the front axle gaskets.**



**If the engine is run indoors, exhaust extraction equipment must be connected to the engine's exhaust pipe.**

4. Disengage the front axle's clutch release lever.



**NOTE! The oil is drawn into the system very quickly. The tank must be filled up continuously until it remains full in order to fill the circuit and make sure air is not drawn into the system (something which must never be allowed to happen).**

5. Set the accelerator pedal to the forward position, locking it using a wooden wedge (29).
6. Run in the forward position for one minute.
7. Move the wooden wedge and set the accelerator pedal to the reverse position. Continue filling with oil.
8. Run in reverse mode for one minute.

9. Change driving direction every minute as indicated above and continue filling with oil until the bubbling in the reservoir stops.
10. Switch off the engine, replace the cover (25:B) on the fluid tank and close the bonnet.
11. Activate the machine at various speeds for several minutes and adjust the fluid level in the tank if necessary.

### 9.8 BELT TRANSMISSIONS CHECK

check that all belts are intact.



**For the frequency of this intervention see chapter 13.**

### 9.9 STEERING



**For the frequency of this intervention see chapter 13.**

#### 9.9.1 Checks

Gently turn the steering wheel back and forth. There must be no mechanical play in the steering chains.

#### 9.9.2 Adjustment (31)

Adjust the steering chains if required as follows:

1. Put the machine in the straight-ahead position.
2. Adjust the steering chains by means of the two nuts, located under the central point (31).
3. Adjust both nuts by the same amount until there is no play.
4. Test drive the machine, moving it forward in a straight line and checking that the steering wheel is not off centre.
5. If the steering wheel is off centre, slacken one nut and tighten the other.



**Do not over tension the steering chains. This would make the steering too stiff and increase wear on the chains.**

### 9.10 BATTERY

For the type of battery installed on the machine, please refer to "0 TECHNICAL DATA TABLE"



**CAUTION! Battery acid is corrosive and contact with it is harmful.**

**Handle the battery with care taking care not to let acid leak out.**



**Acid can cause serious injuries if it comes into contact with eyes or skin. If**

**any part of the body comes into contact with acid, rinse immediately with copious amounts of water and seek medical attention immediately.**

The battery fluid does not need checking or topping up.

The only maintenance operation required is charging, for example after extended storage.

The battery can be charged:

- by the engine,
- by a battery charger.

#### 9.10.1 Charging by the engine

This method is only an option if there is still enough charge in the battery to be able to start the engine.

- If the battery is new, connect the relative leads.
- Take the machine outside.
- Start the engine by following the instructions provided in this manual.
- Leave the engine running continuously for 45 minutes (the time needed to fully charge the battery).
- Stop the engine.

#### 9.10.2 Charging with a battery charger



**Use a constant voltage battery charger. Use of a standard charger may damage the battery. For further information, please contact your dealer.**



**Before connecting the battery charger, disconnect the battery from the electrical system.**

#### 9.10.3 Disassembly/assembly

The battery is housed under the bonnet.

During removal/installation of the battery, connect and disconnect the leads as follows:

1. During removal. First disconnect the black lead from the battery's negative terminal (-). Then disconnect the red lead from the battery's positive terminal (+).
2. During installation: First connect the red cable to the battery's positive terminal (+). Then connect the black cable to the battery's negative terminal (-).



**If the leads are disconnected/connected in the wrong order, there is a**

risk of a short-circuit and damage to the battery.

Inverting the cable connections will damage the alternator and the battery. Tighten the cables securely. Loose cables can cause a fire.

The engine must never be driven with the battery disconnected. There is a risk of serious damage to the alternator and the electrical system.

#### 9.10.4 Cleaning

If the battery terminals are coated with oxide, they should be cleaned.

Clean the battery terminals with a wire brush and lubricate them with terminal grease.

#### 9.11 AIR FILTER, ENGINE



For the frequency of this intervention see chapter 13.



For this maintenance operation, see also the manual for the engine supplied with the machine.

#### 9.11.1 Cleaning / Replacement - mod.: [B&S Power Built] [B&S Intek] (32)



For the frequency of this intervention see chapter 13.



**NOTE! The filters should be cleaned/replaced more often if the machine operates on very dusty ground.**

Remove/install the air filters as follows:

1. Clean carefully around the air filter housing (32:A).
2. Remove the air filter cover by unscrewing the two screws.
3. Remove the paper filter (32:B). Make sure that no dirt gets into the carburettor. Clean the air filter housing.
4. Clean the paper filter by tapping it gently against a flat surface. If the filter is very dirty, replace it.
5. Assemble the filter by performing the above instructions in reverse order.

Compressed air or petroleum-based solvents such as kerosene must not be used for cleaning the paper filter insert. This will damage the filter.

The paper filter insert must not be oiled.

#### 9.11.2 Cleaning / Replacement - mod.: [B&S Vanguard] (33)



For the frequency of this intervention see chapter 13.



**NOTE! The filters should be cleaned/replaced more often if the machine operates on very dusty ground.**

Remove/install the air filters as follows:

1. Carefully clean around the air filter cover.
2. Remove the air filter cover (33:A) by removing the two clamps.
3. Dismantle the filter assembly (33:B). The pre-filter is placed over the air filter. Make sure that no dirt gets into the carburettor. Clean the air filter housing.
4. Clean the paper filter by tapping it gently against a flat surface. If the filter is very dirty, replace it.
5. Clean the pre-filter. If the filter is very dirty, replace it.
6. Assemble the filter by performing the above instructions in reverse order.

#### 9.11.3 Replace the spark plug



For the frequency of this intervention see chapter 13.

Before removing the spark plug, clean around its mounting.

For the type of spark plug and relative spark gap, please refer to "0 TECHNICAL DATA TABLE".

#### 9.11.4 Cleaning the air intake.



For the frequency of this intervention see chapter 13.

See figure (32:C).

The engine is air-cooled.

A blocked cooling system can damage the engine.

More meticulous cleaning of the cooling system should be carried out during each basic service.

#### 9.12 LUBRICATION (30)



For the frequency of this intervention see chapter 13.



Object	Action	Fig.
Centre point	4 grease nipples Use a grease nipple filled with multi-purpose grease. Pump until the grease seeps out.	30A
Steering chains	Brush the chain clean with a wire brush. Lubricate with universal chain spray.	-
Tensioning arms	Lubricate the support points with oil when each control is activated. Ideally this operation should be carried out by two people.	30B
Control cables	Lubricate the cable ends with oil when each control is activated. This operation must be carried out by two people.	30C

### 9.13 FUSES (34)

Destination	Fuse
Fuel valve power supply	10 A
Electrical cutting height adjustment power supply	20 A
Electrical system power supply	30 A

## 10 ASSISTANCE AND REPAIRS

This manual provides all the necessary information to run the machine and for correct basic maintenance operations which can be performed by the user.

Any regulations and maintenance operations not described herein must be carried out by your Dealer or Authorized Service Centre, which have the necessary knowledge and equipment to ensure that the work is carried out correctly, maintaining the correct degree of safety and the original operating conditions of the machine.



**Before performing any servicing operations:**

- Place the machine on a flat surface.
- Activate the parking brake (10:B)

c. Stop the engine.

d. Remove the key from the ignition.

Authorized service workshops carry out guaranteed repairs and maintenance.

Always use genuine spare parts.



**Genuine STIGA SpA spare parts and accessories were designed specifically for STIGA SpA machines.**

**Please remember that non-genuine spare parts and accessories have not been verified or approved by STIGA SpA.**



**The use of non-genuine spare parts and accessories could adversely affect machine operation and safety.**

**STIGA SpA shall decline all liability in the event of injuries or damages caused by such parts.**

**Genuine spare parts are supplied by authorized assistance workshops and dealers.**



**It is advisable to send your machine once a year to an authorized service workshop for servicing, assistance and safety device inspection.**

## 11 STORAGE

- Empty the fuel tank:
    - Start the machine's engine and leave it running until it stops.
  - Change the oil when the engine is still warm.
  - Thoroughly clean the whole machine. It is particularly important to clean the bottom side of the cutting means assembly.
  - If the paintwork is damaged, touch it up to prevent rust.
  - Place the machine in a covered, dry place.
- For machines with electric starter:**  
If the storage temperature is correct, simply recharge the battery every four months.



**Charge the battery before putting the machine into storage.**

**The battery can be seriously damaged if it is put into storage flat.**

## 12 TERMS OF PURCHASE

The warranty covers all material and manufacturing defects.

The user must follow all the instructions provided in the accompanying documentation.

The warranty does not cover damages caused by:

- failure to become familiar with the documentation accompanying the machine,
- carelessness,
- incorrect or prohibited use or assembly,
- use of non-genuine spare parts,
- use of accessories not supplied or approved by STIGA S.p.A..

The warranty does not cover:

- Normal wear and tear on wear parts such as the auger, etc..
- normal wear and tear
- engines. Engines are covered by the warranty provided by the relative manufacturer in compliance with the specified terms and conditions.

The purchaser is protected by his own national legislation. The purchaser's rights envisaged by the national laws in his own country are not in any way restricted by this warranty.

## 13 MAINTENANCE SUMMARY TABLE

Intervention	Frequency		ref. / Ref. Fig.
	service hours	calendar months	
	First time	Then every	
<b>MACHINE</b>			
Check all fasteners	-	Before each use	-
Safety checks/check controls	-	Before each use	-
Check tyre pressure	-	Before each use	-
General cleaning and inspection	-	At the end of each use	-
General lubrication	-	50 hours and after each wash	9.12
Check the drive belts for wear	5 hours	50 hours	9.8
Check/correct steering	5 hours	100 hours	9.9
Battery charging	-	Before putting into storage For machines with an electric starter: carry out a top-up charge every four months.	9.10
Cleaning the battery terminals	-	When there is oxidization.	9.10.4
<b>ENGINES/TRANSMISSION (general)</b>			
Check / Top up engine oil	-	Before each use	9.5.1
Replacing / Filling the engine oil	5 hours	50 hours / 12 months	9.5.2
Filter replacement	-	100 hours	9.5.3
Replace fuel filter	5 hours	50 hours / 12 months	9.6
Replacing the spark plugs	-	200 hours	9.11.3
Cleaning the air intake	-	50 hours	9.11.4
Check/top up transmission fluid	1 hours	50 hours	9.7
Change transmission fluid	5 hours	200 hours	9.7
<b>Engine mod. B&amp;S Power Built</b>			

Intervention	Frequency		ref. / Ref. Fig.
	service hours/calendar months		
Clean/replace the paper air filter	-	100 hours	9.11.1 (1)
<b>Engine mod. B&amp;S Intek</b>			
Clean/replace the foam air pre-filter	-	25 hours	9.11.2 (1)
Clean/replace the paper air filter	-	100 hours	9.11.2 (1)
(1) Clean more frequently when operating in particularly demanding conditions or when there is debris in the air.			

## 14 TROUBLESHOOTING

Problem	Probable cause	Remedy
<b>1. The starter motor does not turn.</b>	Battery not charged enough.	Recharge the flat battery.
	Battery not connected.	Check the connections.
	Fuse 20A blown.	Replace the fuse
<b>2. The starter motor turns but the engine doesn't start. With the ignition key in the start position, the starter motor turns but the engine doesn't start.</b>	Fuel cock closed.	Open the fuel cock.
	No fuel flow.	- Check the fuel level in the tank. - Check the fuel filter.
	Ignition fault.	- Check the spark plug cap is securely in place. - Check the spark gap and that the electrodes are clean.
<b>3. Difficulty in engine start-up or engine runs irregularly.</b>	Carburettor problems.	Clean or replace the air filter.
<b>4. Drop in engine performance during cutting.</b>	Forward speed too high in relation to the cutting height.	Reduce the forward speed and/or raise the cutting height.
<b>5. The engine stops for no apparent reason.</b>	- Fuel tank empty.	Fill the fuel tank (if the problem persists, contact an authorised assistance centre).
	- Try to restart the engine.	
<b>6. Uneven cutting.</b>		Check the tyre pressure.
	The cutting means sharpness level is low.	Contact an authorised assistance centre.
	Forward speed too high in relation to the height of the grass being cut.	Reduce the forward speed and/or raise the cutting height.
	The cutting means assembly is full of grass.	- Wait for the grass to dry. - Clean the cutting means assembly.
<b>7. Abnormal vibration during use.</b>	- Unbalanced cutting means.	Contact an authorised assistance centre for inspection, replacement or repair operations.
	- Slackened cutting means.	
	- loose components.	
	- possible damage.	

<b>Problem</b>	<b>Probable cause</b>	<b>Remedy</b>
<b>8. With the engine running, activation of the traction pedal does not move the machine.</b>	"Disengage transmission" lever in the disengaged position.	Engage the transmission.
<b>If any of the faults listed below occurs, replace the relevant fuse.</b>		
<b>9. The engine does not start or starts and stops immediately. The battery is charged.</b>	Fuse 10A blown.	Replace fuse 10A.
<b>10. Electrical cutting height adjustment does not work.</b>	Fuse 20A blown.	Replace fuse 20A.
<b>11. All electrical functions are out of operation. The battery is charged.</b>	Fuse 30A blown.	Replace fuse 30A.

If problems persist after the operations above have been performed, contact your dealer.



**Warning! Never attempt to carry out complicated repairs without the necessary tools or technical ability. Any poorly performed interventions will automatically nullify the warranty and exonerate the manufacturer from all liability.**

**DICHIARAZIONE CE DI CONFORMITÀ (Produttori Originali)**  
(Direttiva Macchine 2006/42/CE, Allegato II, parte A)

1. La Società **STISA S.p.A.** - Via del Lavoro, 5 - 31033 Casellina Veneto (TV) - Italy
2. Dichiaro sotto la propria responsabilità, che la macchina: **Tascata con cinghiale a bordo scivolo / foglio cines**

a) Tipo / Modello Base:

P 901 C, P 901 C W, P 901 C 4W, P 901 CH, P 901 P, P 901 PH

b) Descrizione di costruzione:

c) Modificata

d) Marca:

a scoppio

3.  confermo alle specifiche delle macchine:

- **MD: 2006/42/CE**

a) Ente Certificatore:

/

b) Esame CE del tipo:

/

- **CMC: 2006/42/CE, ANNEX VI - 2006/42/CE**

D. Lgs. 262/2002, ANNEX VI, proc. 1 (Italy)

a) Ente Certificatore:

**NTD 67-TÜV Rheinland LEA Produkt GmbH**  
Tilgmannstr. 2, 50461 Köln - Germany

- **EMC: 2014/53/EU**

4. Riferisco alle Norme armonizzate:

EN ISO 5395-1:2013+A1:2013

EN 55012:2007/AM1:2009

EN ISO 5395-3:2013+A1:2017+A2:2018

EN ISO 14982:2009

a) Livello di potenza sonora misurato

98,5 dB(A)

b) Livello di potenza sonora garantita

100 dB(A)

c) Altezza di foglio

95, 100, 105, 110, 125 cm

a) Persona autorizzata a compilare il Fascicolo Tecnico:

**STISA S.p.A.**  
Via del Lavoro, 5  
31033 Casellina Veneto (TV) - Italia

a) Casellina V.3a, 01.06.2018

Officer VP R&D & Engineering  
Maurizio Tassinari

<p><b>FR</b> (Traducción de la versión original)</p> <p><b>CE</b> (Declaration of Conformity)  <b>Directiva Máquinas 2006/42/CE, Anexo K, parte A</b></p> <ol style="list-style-type: none"> <li>1. Declaración de conformidad</li> <li>2. Declaración sobre su propia responsabilidad que el fabricante, el fabricante o el importador asume sobre el producto</li> <li>3. Tipo: Máquina de Baza</li> <li>4. Marca / Anexo de construcción</li> <li>5. Motor: motor a gasolina</li> <li>6. Descripción de las especificaciones técnicas</li> <li>7. Exención de las prescripciones de diseño</li> <li>8. Organismo de certificación</li> <li>9. Exención CE de Tipo</li> <li>10. Referencia a Normas armonizadas</li> <li>11. Número de patente o número de inscripción</li> <li>12. Lugar y fecha de emisión</li> <li>13. Nombre del fabricante o del importador</li> <li>14. Firma del fabricante o del importador</li> </ol>	<p><b>ES</b> (Traducción de la versión original)</p> <p><b>CE</b> (Declaración de Conformidad)  <b>Máquina Directiva 2006/42/CE, Anexo K, parte A</b></p> <ol style="list-style-type: none"> <li>1. La Declaración de conformidad</li> <li>2. Declaración sobre su propia responsabilidad que el fabricante, el fabricante o el importador asume sobre el producto</li> <li>3. Tipo: Máquina de Baza</li> <li>4. Marca / Anexo de construcción</li> <li>5. Motor: motor a gasolina</li> <li>6. Descripción de las especificaciones técnicas</li> <li>7. Exención de las prescripciones de diseño</li> <li>8. Organismo de certificación</li> <li>9. Exención CE de Tipo</li> <li>10. Referencia a Normas armonizadas</li> <li>11. Número de patente o número de inscripción</li> <li>12. Lugar y fecha de emisión</li> <li>13. Nombre del fabricante o del importador</li> <li>14. Firma del fabricante o del importador</li> </ol>	<p><b>DE</b> (Übersetzung der Originaldokumentation)</p> <p><b>CE</b> (Erklärung der Konformität)  <b>Maschinenrichtlinie 2006/42/EG, Anhang II, Teil A</b></p> <ol style="list-style-type: none"> <li>1. Erklärung der Konformität</li> <li>2. Erklärung über die eigene Verantwortung für das Produkt</li> <li>3. Typ: Rasenmäher</li> <li>4. Hersteller / Baujahr</li> <li>5. Motor: Benzinmotor</li> <li>6. Beschreibung der technischen Spezifikationen</li> <li>7. Befreiung von den Konformitätsanforderungen</li> <li>8. Zertifizierungsstelle</li> <li>9. Befreiung CE vom Typ</li> <li>10. Verweis auf Harmonisierte Normen</li> <li>11. Patentschutz- oder Registrierungsnummer</li> <li>12. Ort und Datum</li> <li>13. Name des Herstellers / Importeurs</li> <li>14. Unterschrift des Herstellers / Importeurs</li> </ol>	<p><b>NO</b> (Oversettelse av original dokumentasjon)</p> <p><b>CE</b> (Erklæring om samsvarighet)  <b>Masjineriktiv 2006/42/EF, Vedlegg II, del A</b></p> <ol style="list-style-type: none"> <li>1. Erklæring om samsvarighet</li> <li>2. Erklæring om egen ansvar for produktet</li> <li>3. Maskintype / konstruksjonsår</li> <li>4. Maskin / konstruksjonsår</li> <li>5. Motor / Brennstoff</li> <li>6. Beskrivelse av tekniske spesifikasjoner</li>7. Fritakelse fra samsvarhetskravene <li>8. Godkjenning</li> <li>9. Fritakelse CE fra type</li> <li>10. Referanse til harmoniserte standarder</li> <li>11. Patentskjermingsnummer</li> <li>12. Sted og dato</li> <li>13. Navn på produsent / importør</li> <li>14. Produsentens underskrift</li> </ol>	<p><b>EU</b> (Překlad originálního dokumentu)</p> <p><b>CE</b> (Prohlášení o shodě)  <b>Směrnice 2006/42/ES, příloha II, část A</b></p> <ol style="list-style-type: none"> <li>1. Prohlášení o shodě</li> <li>2. Prohlášení o vlastní odpovědnosti, za kterou výrobce, výrobce nebo dovozce odpovídá</li> <li>3. Typ: Žací stroj</li> <li>4. Typ: Motor: Benzinový</li> <li>5. Typ: Výrobce: Datum</li> <li>6. Popis technických specifikací</li> <li>7. Odkaz na normy harmonizované</li> <li>8. Odkaz na číslo patentu nebo registrační číslo</li> <li>9. Místo a datum</li> <li>10. Podpis výrobce / dovozce</li> <li>11. Podpis výrobce / dovozce</li> </ol>
<p><b>NL</b> (Vertaling van de oorspronkelijke documentatie)</p> <p><b>CE</b> (Verklaring van Conformiteit)  <b>Directiva Masinilor 2006/42/CE, Anexa K, partea A</b></p> <ol style="list-style-type: none"> <li>1. Declarația de conformitate</li> <li>2. Declarația asupra propriei răspunderii ca fabricant, producător sau distribuitor</li> <li>3. Tip: Mașină de Bază</li> <li>4. Marca / Anexa de construcție</li> <li>5. Motor: motor benzina</li> <li>6. Descrierea specificațiilor tehnice</li> <li>7. Exențiere de la cerințele de proiectare</li> <li>8. Organism de certificare</li> <li>9. Exențiere CE de tip</li> <li>10. Referință la standardele armonizate</li> <li>11. Numărul de patent sau numărul de înregistrare</li> <li>12. Locul și data emiterii</li> <li>13. Numele fabricantului / distribuitorului</li> <li>14. Semnătura fabricantului / distribuitorului</li> </ol>	<p><b>ES</b> (Traducción del Manual Original)</p> <p><b>CE</b> (Declaración de Conformidad)  <b>Directiva Máquinas 2006/42/CE, Anexo K, parte A</b></p> <ol style="list-style-type: none"> <li>1. Declaración de conformidad</li> <li>2. Declaración sobre su propia responsabilidad que el fabricante, el fabricante o el importador asume sobre el producto</li> <li>3. Tipo: Máquina de Baza</li> <li>4. Marca / Anexo de construcción</li> <li>5. Motor: motor a gasolina</li> <li>6. Descripción de las especificaciones técnicas</li> <li>7. Exención de las prescripciones de diseño</li> <li>8. Organismo de certificación</li> <li>9. Exención CE de Tipo</li> <li>10. Referencia a Normas armonizadas</li> <li>11. Número de patente o número de inscripción</li> <li>12. Lugar y fecha de emisión</li> <li>13. Nombre del fabricante o del importador</li> <li>14. Firma del fabricante o del importador</li> </ol>	<p><b>PT</b> (Tradução do manual original)</p> <p><b>CE</b> (Declaração de Conformidade)  <b>Directiva Máquinas 2006/42/CE, Anexo K, parte A</b></p> <ol style="list-style-type: none"> <li>1. Declaração de conformidade</li> <li>2. Declaração sobre a própria responsabilidade que o fabricante, o fabricante ou o importador assume sobre o produto</li> <li>3. Tipo: Máquina de Baza</li> <li>4. Marca / Anexo de construção</li> <li>5. Motor: motor a gasolina</li> <li>6. Descrição das especificações técnicas</li> <li>7. Exenção de das prescrições de projeto</li> <li>8. Organismo de certificação</li> <li>9. Exenção CE do tipo</li> <li>10. Referência às Normas harmonizadas</li> <li>11. Número de patente ou número de inscrição</li> <li>12. Local e data de emissão</li> <li>13. Nome do fabricante / importador</li> <li>14. Assinatura do fabricante / importador</li> </ol>	<p><b>ET</b> (Übersetzung des Originaldokuments)</p> <p><b>CE</b> (Prohlášení o shodě)  <b>Směrnice 2006/42/ES, příloha II, část A</b></p> <ol style="list-style-type: none"> <li>1. Prohlášení o shodě</li> <li>2. Prohlášení o vlastní odpovědnosti, za kterou výrobce, výrobce nebo dovozce odpovídá</li> <li>3. Typ: Žací stroj</li> <li>4. Typ: Motor: Benzinový</li> <li>5. Typ: Výrobce: Datum</li> <li>6. Popis technických specifikací</li> <li>7. Odkaz na normy harmonizované</li> <li>8. Odkaz na číslo patentu nebo registrační číslo</li> <li>9. Místo a datum</li> <li>10. Podpis výrobce / dovozce</li> <li>11. Podpis výrobce / dovozce</li> </ol>	<p><b>PL</b> (Tłumaczenie oryginalnego dokumentu)</p> <p><b>CE</b> (Proświadczenie o zgodności)  <b>dyrektywa 2006/42/WE, Załącznik II, część A</b></p> <ol style="list-style-type: none"> <li>1. Proświadczenie o zgodności</li> <li>2. Proświadczenie o własnej odpowiedzialności, za którą producent, producent lub importer odpowiada</li> <li>3. Typ: Kosiarka</li> <li>4. Typ: Silnik: Benzynowy</li> <li>5. Typ: Wytwórca: Data</li> <li>6. Opis technicznych specyfikacji</li> <li>7. Odniesienie do norm harmonizowanych</li> <li>8. Odniesienie do numeru patentu lub numeru rejestracji</li> <li>9. Miejsce i data wydania</li> <li>10. Podpis producenta / importera</li> <li>11. Podpis producenta / importera</li> </ol>
<p><b>EL</b> (Μετάφραση της πρωτότυπης της έγγραφου)</p> <p><b>FR</b> (Traduction de l'original)</p> <p><b>CE</b> (Déclaration de Conformité)  <b>Directive Machines 2006/42/CE, Annexe K, partie A</b></p> <ol style="list-style-type: none"> <li>1. Déclaration de conformité</li> <li>2. Déclaration sur sa propre responsabilité que le fabricant, le fabricant ou l'importateur assume sur le produit</li> <li>3. Type: Machine à base</li> <li>4. Marque / Annexe de construction</li> <li>5. Moteur: Moteur à essence</li> <li>6. Description des spécifications techniques</li> <li>7. Exemption de la prescription de conception</li> <li>8. Organisme de certification</li> <li>9. Exemption CE de type</li> <li>10. Référence aux normes harmonisées</li> <li>11. Numéro de brevet ou numéro d'inscription</li> <li>12. Lieu et date de délivrance</li> <li>13. Nom du fabricant / importateur</li> <li>14. Signature du fabricant / importateur</li> </ol>	<p><b>DK</b> (Oversættelse af originaldokumentation)</p> <p><b>CE</b> (Erklæring om overensstemmelse)  <b>Masjineriktiv 2006/42/EF, Vedlegg II, del A</b></p> <ol style="list-style-type: none"> <li>1. Erklæring om overensstemmelse</li> <li>2. Erklæring om egen ansvar for produktet</li> <li>3. Maskintype / konstruksjonsår</li> <li>4. Maskin / konstruksjonsår</li> <li>5. Motor / Brennstoff</li> <li>6. Beskrivelse av tekniske spesifikasjoner</li> <li>7. Befrielse fra samsvarhetskravene</li> <li>8. Godkjenning</li> <li>9. Fritakelse CE fra type</li> <li>10. Referanse til harmoniserte standarder</li> <li>11. Patentskjermingsnummer</li> <li>12. Sted og dato</li> <li>13. Navn på produsent / importør</li> <li>14. Produsentens underskrift</li> </ol>	<p><b>EU</b> (Překlad originálního dokumentu)</p> <p><b>CE</b> (Prohlášení o shodě)  <b>Směrnice 2006/42/ES, příloha II, část A</b></p> <ol style="list-style-type: none"> <li>1. Prohlášení o shodě</li> <li>2. Prohlášení o vlastní odpovědnosti, za kterou výrobce, výrobce nebo dovozce odpovídá</li> <li>3. Typ: Žací stroj</li> <li>4. Typ: Motor: Benzinový</li> <li>5. Typ: Výrobce: Datum</li> <li>6. Popis technických specifikací</li> <li>7. Odkaz na normy harmonizované</li> <li>8. Odkaz na číslo patentu nebo registrační číslo</li> <li>9. Místo a datum</li> <li>10. Podpis výrobce / dovozce</li> <li>11. Podpis výrobce / dovozce</li> </ol>	<p><b>RU</b> (Перевод оригинального документа)</p> <p><b>CE</b> (Объявление о соответствии)  <b>Директива 2006/42/ЕС, приложение II, часть А</b></p> <ol style="list-style-type: none"> <li>1. Объявление о соответствии</li> <li>2. Объявление о своей ответственности за продукт</li> <li>3. Тип: Трактор</li> <li>4. Тип: Двигатель: Бензиновый</li> <li>5. Тип: Производитель: Дата</li> <li>6. Описание технических характеристик</li> <li>7. Освобождение от требований к проектированию</li> <li>8. Сертифицирующий орган</li> <li>9. Освобождение CE от типа</li> <li>10. Ссылка на гармонизированные стандарты</li> <li>11. Номер патента или регистрационный номер</li> <li>12. Место и дата выпуска</li> <li>13. Имя производителя / импортера</li> <li>14. Подпись производителя / импортера</li> </ol>	<p><b>RU</b> (Перевод оригинального документа)</p> <p><b>CE</b> (Объявление о соответствии)  <b>Директива 2006/42/ЕС, приложение II, часть А</b></p> <ol style="list-style-type: none"> <li>1. Объявление о соответствии</li> <li>2. Объявление о своей ответственности за продукт</li> <li>3. Тип: Трактор</li> <li>4. Тип: Двигатель: Бензиновый</li> <li>5. Тип: Производитель: Дата</li> <li>6. Описание технических характеристик</li> <li>7. Освобождение от требований к проектированию</li> <li>8. Сертифицирующий орган</li> <li>9. Освобождение CE от типа</li> <li>10. Ссылка на гармонизированные стандарты</li> <li>11. Номер патента или регистрационный номер</li> <li>12. Место и дата выпуска</li> <li>13. Имя производителя / импортера</li> <li>14. Подпись производителя / импортера</li> </ol>



<p><b>PL</b> (Tłumaczenie oryginalnego dokumentu)</p> <p><b>CE</b> (Proświadczenie o zgodności)  <b>dyrektywa 2006/42/WE, Załącznik II, część A</b></p> <ol style="list-style-type: none"> <li>1. Proświadczenie o zgodności</li> <li>2. Proświadczenie o własnej odpowiedzialności, za którą producent, producent lub importer odpowiada</li> <li>3. Typ: Kosiarka</li> <li>4. Typ: Silnik: Benzynowy</li> <li>5. Typ: Wytwórca: Data</li> <li>6. Opis technicznych specyfikacji</li> <li>7. Odniesienie do norm harmonizowanych</li> <li>8. Odniesienie do numeru patentu lub numeru rejestracji</li> <li>9. Miejsce i data wydania</li> <li>10. Podpis producenta / importera</li> <li>11. Podpis producenta / importera</li> </ol>	<p><b>ES</b> (Traducción del original)</p> <p><b>CE</b> (Declaración de Conformidad)  <b>Directiva Máquinas 2006/42/CE, Anexo K, parte A</b></p> <ol style="list-style-type: none"> <li>1. Declaración de conformidad</li> <li>2. Declaración sobre su propia responsabilidad que el fabricante, el fabricante o el importador asume sobre el producto</li> <li>3. Tipo: Máquina de Baza</li> <li>4. Marca / Anexo de construcción</li> <li>5. Motor: motor a gasolina</li> <li>6. Descripción de las especificaciones técnicas</li> <li>7. Exención de las prescripciones de diseño</li> <li>8. Organismo de certificación</li> <li>9. Exención CE de Tipo</li> <li>10. Referencia a Normas armonizadas</li> <li>11. Número de patente o número de inscripción</li> <li>12. Lugar y fecha de emisión</li> <li>13. Nombre del fabricante / importador</li> <li>14. Firma del fabricante / importador</li> </ol>	<p><b>SK</b> (Preklad pôvodného dokumentu)</p> <p><b>CE</b> (Prohlášení o shodě)  <b>Směrnice 2006/42/ES, příloha II, část A</b></p> <ol style="list-style-type: none"> <li>1. Prohlášení o shodě</li> <li>2. Prohlášení o vlastní odpovědnosti, za kterou výrobce, výrobce nebo dovozce odpovídá</li> <li>3. Typ: Žací stroj</li> <li>4. Typ: Motor: Benzinový</li> <li>5. Typ: Výrobce: Datum</li> <li>6. Popis technických specifikací</li> <li>7. Odkaz na normy harmonizované</li> <li>8. Odkaz na číslo patentu nebo registrační číslo</li> <li>9. Místo a datum</li> <li>10. Podpis výrobce / dovozce</li> <li>11. Podpis výrobce / dovozce</li> </ol>
--	---	---

<p><b>RU</b> (Перевод оригинального документа)</p> <p><b>CE</b> (Объявление о соответствии)  <b>Директива 2006/42/ЕС, приложение II, часть А</b></p> <ol style="list-style-type: none"> <li>1. Объявление о соответствии</li> <li>2. Объявление о своей ответственности за продукт</li> <li>3. Тип: Трактор</li> <li>4. Тип: Двигатель: Бензиновый</li> <li>5. Тип: Производитель: Дата</li> <li>6. Описание технических характеристик</li> <li>7. Освобождение от требований к проектированию</li> <li>8. Сертифицирующий орган</li> <li>9. Освобождение CE от типа</li> <li>10. Ссылка на гармонизированные стандарты</li> <li>11. Номер патента или регистрационный номер</li> <li>12. Место и дата выпуска</li> <li>13. Имя производителя / импортера</li> <li>14. Подпись производителя / импортера</li> </ol>	<p><b>ES</b> (Traducción del original)</p> <p><b>CE</b> (Declaración de Conformidad)  <b>Directiva Máquinas 2006/42/CE, Anexo K, parte A</b></p> <ol style="list-style-type: none"> <li>1. Declaración de conformidad</li> <li>2. Declaración sobre su propia responsabilidad que el fabricante, el fabricante o el importador asume sobre el producto</li> <li>3. Tipo: Máquina de Baza</li> <li>4. Marca / Anexo de construcción</li> <li>5. Motor: motor a gasolina</li> <li>6. Descripción de las especificaciones técnicas</li> <li>7. Exención de las prescripciones de diseño</li> <li>8. Organismo de certificación</li> <li>9. Exención CE de Tipo</li> <li>10. Referencia a Normas armonizadas</li> <li>11. Número de patente o número de inscripción</li> <li>12. Lugar y fecha de emisión</li> <li>13. Nombre del fabricante / importador</li> <li>14. Firma del fabricante / importador</li> </ol>	<p><b>ET</b> (Übersetzung des Originaldokuments)</p> <p><b>CE</b> (Prohlášení o shodě)  <b>Směrnice 2006/42/ES, příloha II, část A</b></p> <ol style="list-style-type: none"> <li>1. Prohlášení o shodě</li> <li>2. Prohlášení o vlastní odpovědnosti, za kterou výrobce, výrobce nebo dovozce odpovídá</li> <li>3. Typ: Žací stroj</li> <li>4. Typ: Motor: Benzinový</li> <li>5. Typ: Výrobce: Datum</li> <li>6. Popis technických specifikací</li> <li>7. Odkaz na normy harmonizované</li> <li>8. Odkaz na číslo patentu nebo registrační číslo</li> <li>9. Místo a datum</li> <li>10. Podpis výrobce / dovozce</li> <li>11. Podpis výrobce / dovozce</li> </ol>
---	---	---

<p><b>PL</b> (Tłumaczenie oryginalnego dokumentu)</p> <p><b>CE</b> (Proświadczenie o zgodności)  <b>dyrektywa 2006/42/WE, Załącznik II, część A</b></p> <ol style="list-style-type: none"> <li>1. Proświadczenie o zgodności</li> <li>2. Proświadczenie o własnej odpowiedzialności, za którą producent, producent lub importer odpowiada</li> <li>3. Typ: Kosiarka</li> <li>4. Typ: Silnik: Benzynowy</li> <li>5. Typ: Wytwórca: Data</li> <li>6. Opis technicznych specyfikacji</li> <li>7. Odniesienie do norm harmonizowanych</li> <li>8. Odniesienie do numeru patentu lub numeru rejestracji</li> <li>9. Miejsce i data wydania</li> <li>10. Podpis producenta / importera</li> <li>11. Podpis producenta / importera</li> </ol>	<p><b>EU</b> (Překlad originálního dokumentu)</p> <p><b>CE</b> (Prohlášení o shodě)  <b>Směrnice 2006/42/ES, příloha II, část A</b></p> <ol style="list-style-type: none"> <li>1. Prohlášení o shodě</li> <li>2. Prohlášení o vlastní odpovědnosti, za kterou výrobce, výrobce nebo dovozce odpovídá</li> <li>3. Typ: Žací stroj</li> <li>4. Typ: Motor: Benzinový</li> <li>5. Typ: Výrobce: Datum</li> <li>6. Popis technických specifikací</li> <li>7. Odkaz na normy harmonizované</li> <li>8. Odkaz na číslo patentu nebo registrační číslo</li> <li>9. Místo a datum</li> <li>10. Podpis výrobce / dovozce</li> <li>11. Podpis výrobce / dovozce</li> </ol>	<p><b>ET</b> (Übersetzung des Originaldokuments)</p> <p><b>CE</b> (Prohlášení o shodě)  <b>Směrnice 2006/42/ES, příloha II, část A</b></p> <ol style="list-style-type: none"> <li>1. Prohlášení o shodě</li> <li>2. Prohlášení o vlastní odpovědnosti, za kterou výrobce, výrobce nebo dovozce odpovídá</li> <li>3. Typ: Žací stroj</li> <li>4. Typ: Motor: Benzinový</li> <li>5. Typ: Výrobce: Datum</li> <li>6. Popis technických specifikací</li> <li>7. Odkaz na normy harmonizované</li> <li>8. Odkaz na číslo patentu nebo registrační číslo</li> <li>9. Místo a datum</li> <li>10. Podpis výrobce / dovozce</li> <li>11. Podpis výrobce / dovozce</li> </ol>
--	--	---

- IT** • Il contenuto e le immagini del presente manuale d'uso sono stati realizzati per conto di STIGA S.p.A. e sono tutelati da diritto d'autore – E' vietata ogni riproduzione o alterazione anche parziale non autorizzata del documento.
- BG** • Съдържанието и изображенията в настоящото ръководство са извършени за STIGA S.p.A. и са защитени с авторски права – Забранява се всяко неотризирано възпроизвеждане или промяна, дори и отчасти на документа.
- BS** • Sadržaj i slike iz ovog korisničkog priručnika napravljeni su isključivo za STIGA S.p.A. i zaštićeni su autorskim pravima – zabranjena je svaka neovlašćena reprodukcija ili izmjena dokumenta, djelomično ili u potpunosti.
- CS** • Obsah a obrázky v tomto návodu k použití byly zpracovány jménem společnosti STIGA S.p.A. a jsou chráněny autorským právem – Reprodukce či nepovolené pozměňování tohoto dokumentu, a to i částečně, je zakázáno.
- DA** • Indhold og illustrationer i denne vejledning er blevet skabt på vegne af STIGA S.p.A. og er beskyttet af ophavsret – Enhver gengivelse eller ændring, også delvis, af dokumentet uden autorisation hertil er forbudt.
- DE** • Inhalt und Bilder dieser Bedienungsanleitung wurden im Namen von STIGA S.p.A. erstellt und sind urheberrechtlich geschützt – Jede nicht genehmigte Vervielfältigung oder Veränderung, auch auszugsweise, dieses Dokumentes ist verboten.
- EL** • Το περιεχόμενο και οι εικόνες στο παρόν εγχειρίδιο χρήσης δημιουργήθηκαν για λογαριασμό της εταιρείας STIGA S.p.A. και προστατεύονται από πνευματικά δικαιώματα – Απαγορεύεται οποιαδήποτε αναπαραγωγή ή τροποποίηση, έστω και μερική, του εγγράφου χωρίς έγκριση.
- EN** • The content and images in this User Manual were produced expressly for STIGA S.p.A. and are protected by copyright – any unauthorised reproduction or modification to the document, either partially or in full, is prohibited.
- ES** • El contenido y las imágenes del presente manual de uso han sido creados por STIGA S.p.A. y están protegidos por los derechos de autor – Se prohíbe toda reproducción o modificación, incluso parcial, no autorizada del documento.
- ET** • Käesoleva kasutusjuhendi sisu ja kujutised on toodetud konkreetselt ettevõttele STIGA S.p.A. ja neile rakendub autorikaitseseadus – dokumendi igasugune osaline või täielik ilma loata reprodutseerimine või muutmine on keelatud.
- FI** • Tämän käyttöoppaan sisältö ja kuvat on valmistettu STIGA S.p.A. -yhtiön toimesta ja niitä suojaa tekijänoikeuslaki. – Asiakirjan kaikenlainen kopioiminen tai muuttaminen, osittainkin, on kielletty ilman erityistä lupaa.
- FR** • Le contenu et les images du présent manuel d'utilisation ont été réalisés pour le compte de STIGA S.p.A. et sont protégés par un droit d'auteur - Toute reproduction ou modification non autorisée, même partielle, du document, est interdite.
- HR** • Sadržaj i slike u ovom priručniku za uporabu izrađeni su za tvrtku STIGA S.p.A. te su obuhvaćeni autorskim pravima – Zabranjuje se neovlašćeno umnožavanje ili prilagodba, djelomična ili u cijelosti, ovog dokumenta.
- HU** • Ennek a használati útmutatónak a tartalma és a benne szereplő képek kizárólag a STIGA S.p.A. számára készültek és szerzői joggal védettek – tilos a dokumentum bármely részének vagy egészének engedély nélküli sokszorosítása és módosítása.
- LT** • Šio naudotojų vadovo turinys ir paveikslėliai skirti tik „STIGA S.p.A.“ ir yra saugomi autorių teisėmis – dokumentą atgaminti ar modifikuoti, visiškai arba iš dalies, yra draudžiama.
- LV** • Šīs lietotāja rokasgrāmatas saturs un attēli ir veidoti tikai STIGA S.p.A. un ir aizsargāti ar autortiesībām. Jebkāda dokumenta vai tā daļas prettiesiska kopēšana vai pārveide ir stingri aizliegta.
- MK** • Содржината и сликите во Упатството за корисникот се подготвени исклучиво за STIGA S.p.A. и се заштитени со авторски права – забрането е сеное делумно или целосно неовластено репродуцирање или измена на документот.
- NL** • De inhoud en de afbeeldingen van deze gebruikshandleiding werden gerealiseerd voor rekening van STIGA S.p.A. en zijn beschermd door het auteursrecht – Elke niet-geautoriseerde reproductie of wijziging, ook gedeeltelijke, van het document is verboden.
- NO** • Innholdet og bildene i denne brukerveiledningen er utført på oppdrag fra STIGA S.p.A. og er beskyttet ved opphavsrett - Enhver gjengivelse eller endring, selv kun delvis, er forbudt.
- PL** • Treść oraz ilustracje zawarte w niniejszej instrukcji obsługi powstały na zlecenie spółki STIGA S.p.A. i są chronione prawami autorskimi – Zabrania się wszelkiego kopiowania bądź modyfikowania, także częściowego, niniejszego dokumentu bez uzyskania stosownej zgody.
- PT** • As imagens e os conteúdos contidos no presente Manual do Utilizador foram expressamente criados para uso exclusivo da STIGA S.p.A., encontrando-se protegidos por direitos de autor. Qualquer tipo de reprodução ou alteração, parcial ou integral, não autorizadas deste Manual estão expressamente proibidas.
- RO** • Conținutul și imaginile din manualul de utilizare de față au fost realizate în numele STIGA S.p.A. și sunt protejate de drepturi de autor – Este interzisă orice reproducere sau modificare chiar și parțială neautorizată a documentului.
- RU** • Тесты и изображения, содержащиеся в настоящем руководстве, были созданы в интересах STIGA S.p.A. и защищены авторскими правами – Любое несанкционированное воспроизведение или изменение документа запрещено.
- SK** • Obsah a obrázky v tomto návode na používanie boli spracované menom spoločnosti STIGA S.p.A. a sú chránené autorským právom – Reprodukcie či nepovolené pozměňovanie tohto dokumentu, a to aj čiastočne, je zakázané.
- SL** • Vsebine in slike v tem uporabniškem priručniku so izdelane za podjetje STIGA S.p.A. in so zaščitene z avtorskimi pravicami – vsakršno nepooblaščenno razmnoževanje ali spreminjanje dokumenta, v celoti ali delno, je prepovedano.
- SR** • Sadržaj i slike ovog priručnika za upotrebu su napravljeni u ime STIGA S.p.A. i zaštićeni su autorskim pravima – Zabranjena je svaka potpuna ili delimična reprodukcija ili izmena dokumenta bez odobrenja.
- SV** • Innehållet och bilderna i denna användarhandbok har framställts för STIGA S.p.A. och skyddas av upphovsrätt – all form av reproduktion eller ändring, även partiell, som inte auktoriserats är förbjuden.
- TR** • Bu Kullanıcı Kilavuzundaki içerik ve resimler ağıkça STIGA S.p.A. için üretimiştir ve telif hakkı ile korunmaktadır – dokümanın izinsiz olarak tamamen ya da kısmen herhangi bir şekilde çoğaltılması ya da değıştirilmesi yasaktır.



.....	 LWA ..... dB
Type: .....	
..... -s/n ..... -Art.N .....	
	

**STIGA S.p.A.**  
Via del Lavoro, 6  
31033 Castelfranco Veneto (TV) ITALY