

CP1 434 Series  
CP1 484 Series

**STIGA**®



- IT** Tosaerba con conducente a piedi - MANUALE DI ISTRUZIONI  
ATTENZIONE: prima di usare la macchina, leggere attentamente il presente libretto.
- BG** Косачка с изправен водач - УПЪТВАНЕ ЗА УПОТРЕБА  
ВНИМАНИЕ: преди да използвате машината прочетете внимателно настоящата книжка.
- BS** Kosilica na guranje - UPUTSTVO ZA UPOTREBU  
PAŽNJA: prije nego što koristite ovu mašinu, pažljivo pročitajte priručnik s uputama.
- CS** Sekačka se stojící obsluhou - NÁVOD K POUŽITÍ  
UPOZORNĚNÍ: před použitím stroje si pozorně přečtete tento návod k použití.
- DA** Plæneklipper betjent af gående personer - BRUGSANVISNING  
ADVARSEL: læs instruktionsbogen omhyggeligt igennem, før du tager denne maskine i brug.
- DE** Handgeführter Rasenmäher - GEBRAUCHSANWEISUNG  
ACHTUNG: vor inbetriebnahme des geräts die gebrauchsanleitung aufmerksam lesen.
- EL** Χλοοκοπτική μηχανή με όρθιο χειριστή - ΟΔΗΓΙΕΣ ΧΡΗΣΗΣ  
ΠΡΟΣΟΧΗ: πριν χρησιμοποιήσετε το μηχάνημα, διαβάστε προσεκτικά το παρόν εγχειρίδιο.
- EN** Pedestrian controlled lawnmower - OPERATOR'S MANUAL  
WARNING: read thoroughly the instruction booklet before using the machine.
- ES** Cortadora de pasto con operador de pie - MANUAL DE INSTRUCCIONES  
ATENCIÓN: antes de utilizar la máquina, leer atentamente el presente manual.
- ET** Seisva juhiga muruniitja - KASUTUSJUHEND  
TÄHELEPANU: enne masina kasutamist lugeda tähelepanelikult antud kasutusjuhendit.
- FI** Kävelen ohjattava ruohonleikkuri - KÄYTTÖOHJEET  
VAROITUS: lue käyttöopas huolellisesti ennen koneen käyttöä.
- FR** Tondeuse à gazon à conducteur à pied - MANUEL D'UTILISATION  
ATTENTION: lire attentivement le manuel avant d'utiliser cette machine.
- HR** Ručno upravljana kosilica trave - PRIRUČNIK ZA UPORABU  
POZOR: prije uporabe stroja, pažljivo pročitajte ovaj priručnik.
- HU** Gyalogvezetésű fűnyírógép - HASZNÁLATI UTASÍTÁS  
FIGYELEM! a gép használatá előtt olvassa el figyelmesen a jelen kézikönyvet.
- LT** Pėsčio operatoriaus valdoma vejarpjovė - NAUDOJIMO INSTRUKCIJOS  
DĖMESIO: prieš naudojant įrenginį, atidžiai perskaityti šį naudotojo vadovą.
- LV** No aizmugures ejot vadāma zāliena plaujmašina  
LIETOŠANAS INSTRUKCIJA - UZMANĪBU: pirms aparāta lietošanas rūpīgi izlasiet doto instrukciju.
- MK** Тревокосачна со оператор на носе - УПАТСТВА ЗА УПОТРЕБА  
ВНИМАНИЕ: прочитайте го внимателно ова упатство пред да ја користите машината.
- NL** Lopend bediende gasmaaier - GEBRUIKERSHANDLEIDING  
LET OP: vooraleer de machine te gebruiken, dient men deze handleiding aandachtig te lezen.
- NO** Håndført gressklipper - INSTRUKSJONSBOK  
ADVARSEL: les denne bruksanvisningen nøye før du bruker maskinen.
- PL** Kosiarzka prowadzona przez operatora pieszego  
INSTRUKCJE OBSŁUGI - OSTRZEŻENIE: przed użyciem maszyny, należy uważnie przeczytać niniejszą instrukcję.
- PT** Corta-relvas para operador apeedo - MANUAL DE INSTRUÇÕES  
ATENÇÃO: antes de usar a máquina, leia atentamente o presente manual.
- RO** Maşină de tuns iarba cu conducător pedestru  
MANUAL DE INSTRUCȚIUNI - ATENȚIE: înainte de a utiliza maşina, citiți cu atenție manualul de față.
- RU** Газонокосилка с пешеходным управлением  
РУКОВОДСТВО ПО ЭКСПЛУАТАЦИИ - ВНИМАНИЕ: прежде чем пользоваться оборудованием, внимательно прочтите это руководство по эксплуатации.
- SK** Kosačka so stojacou obsluhou - NÁVOD NA POUŽITIE  
UPOZORNENIE: pred použitím stroja si pozorne prečítajte tento návod.
- SL** Kosilnica za stoječega delavca - PRIROČNIK ZA UPORABO  
POZOR: preden uporabite stroj, pazljivo preberite priručnik z navodili.
- SR** Kosačica na guranje - PRIRUČNIK SA UPUTSTVIMA  
PAŽNJA: pre korišćenja mašine pažljivo pročitati ovaj priručnik.
- SV** Förlädd gräsklippare - BRUKSANVISNING  
VARNING: läs igenom hela detta häfte innan du använder maskinen.
- TR** Ayak kumandalı çim biçme makinesi - KULLANIM KILAVUZU  
DİKKAT: makineyi kullanmadan önce talimatlar içeren kilavuzu dikkate okuyun.



|  |           |
|--|-----------|
| ITALIANO - Istruzioni Originali .....                                  | <b>IT</b> |
| БЪЛГАРСКИ - Инструкция за експлоатация .....                           | <b>BG</b> |
| BOSANSKI - Prijevod originalnih uputa .....                            | <b>BS</b> |
| ČESKY - Překlad původního návodu k používání .....                     | <b>CS</b> |
| DANSK - Oversættelse af den originale brugsanvisning .....             | <b>DA</b> |
| DEUTSCH - Übersetzung der Originalbetriebsanleitung .....              | <b>DE</b> |
| ΕΛΛΗΝΙΚΑ - Μετάφραση των πρωτοτύπων οδηγιών .....                      | <b>EL</b> |
| ENGLISH - Translation of the original instruction .....                | <b>EN</b> |
| ESPAÑOL - Traducción del Manual Original .....                         | <b>ES</b> |
| EESTI - Algupärase kasutusjuhendi tõlge .....                          | <b>ET</b> |
| SUOMI - Alkuperäisten ohjeiden käännös .....                           | <b>FI</b> |
| FRANÇAIS - Traduction de la notice originale .....                     | <b>FR</b> |
| HRVATSKI - Prijevod originalnih uputa .....                            | <b>HR</b> |
| MAGYAR - Eredeti használati utasítás fordítása .....                   | <b>HU</b> |
| LIETUVIŠKAI - Originalių instrukcijų vertimas .....                    | <b>LT</b> |
| LATVIEŠU - Instrukciju tulkojums no oriģināl valodas .....             | <b>LV</b> |
| МАКЕДОНСКИ - Превод на оригиналните упатства .....                     | <b>MK</b> |
| NEDERLANDS - Vertaling van de oorspronkelijke gebruiksaanwijzing ..... | <b>NL</b> |
| NORSK - Oversettelse av den originale bruksanvisningen .....           | <b>NO</b> |
| POLSKI - Tłumaczenie instrukcji oryginalnej .....                      | <b>PL</b> |
| PORTUGUÊS - Tradução do manual original .....                          | <b>PT</b> |
| ROMÂN - Traducerea manualului fabricantului .....                      | <b>RO</b> |
| РУССКИЙ - Перевод оригинальных инструкций .....                        | <b>RU</b> |
| SLOVENSKY - Preklad pôvodného návodu na použitie .....                 | <b>SK</b> |
| SLOVENŠČINA - Prevod izvornih navodil .....                            | <b>SL</b> |
| SRPSKI - Prevod originalnih uputstva .....                             | <b>SR</b> |
| SVENSKA - Översättning av bruksanvisning i original .....              | <b>SV</b> |
| TÜRKÇE - Orijinal Talimatların Tercümesi .....                         | <b>TR</b> |

1

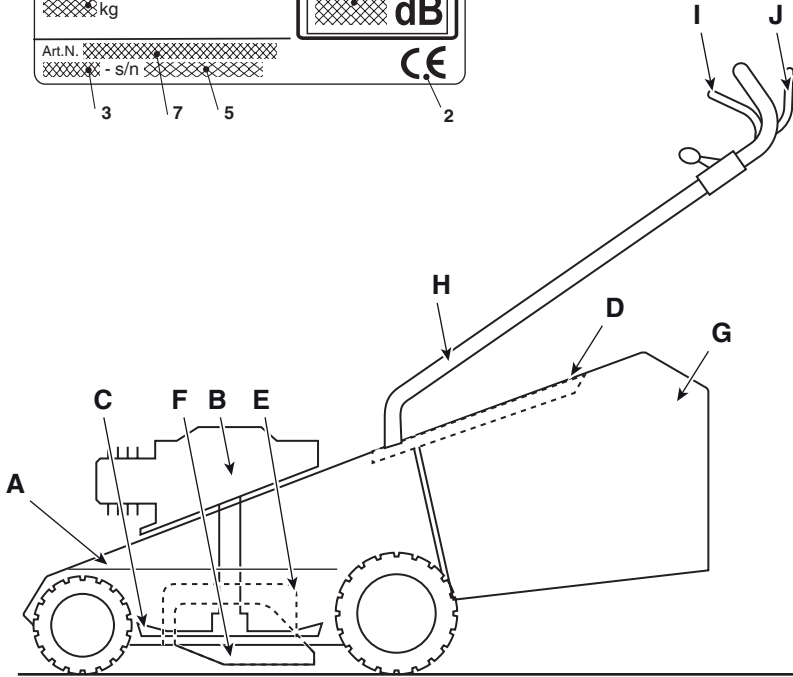
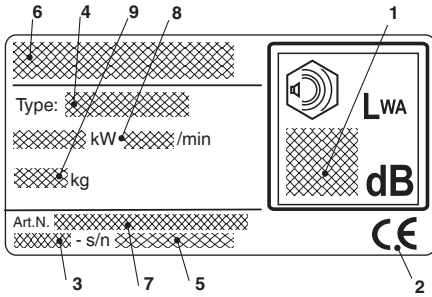

2

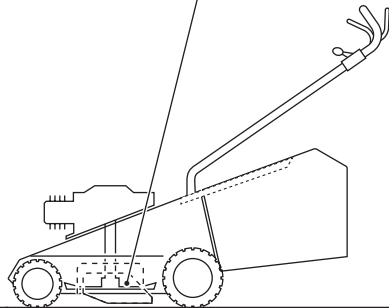
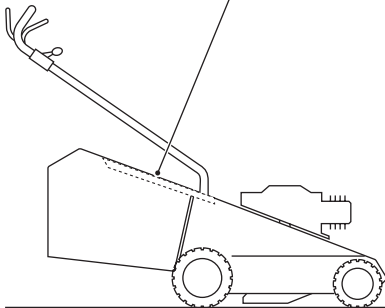

3



4

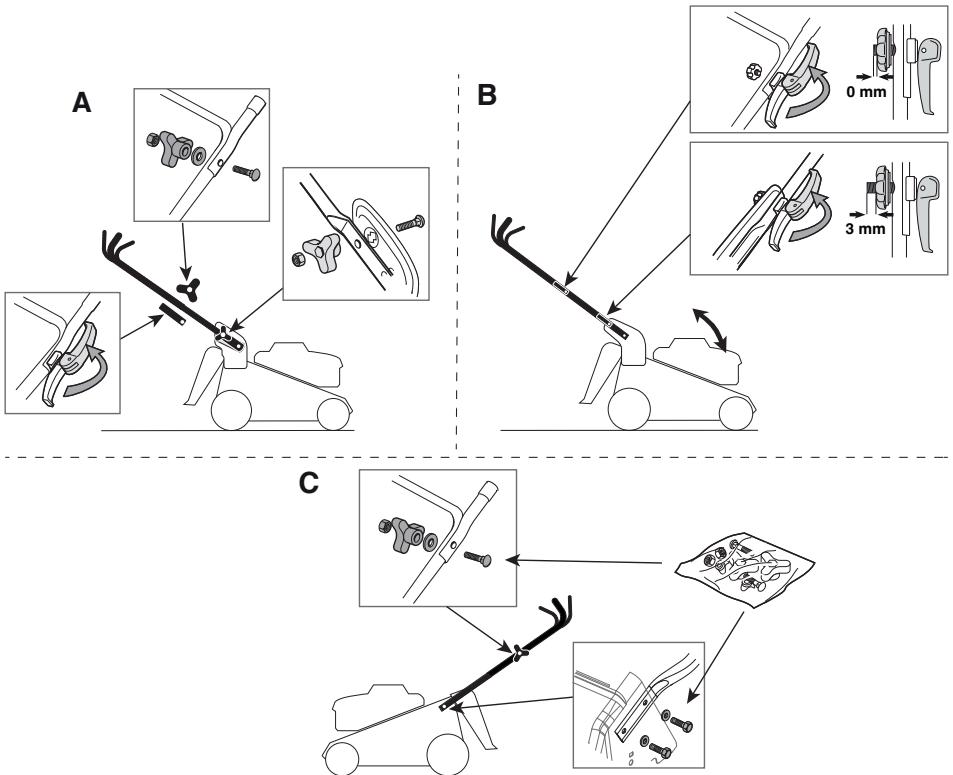

5

1

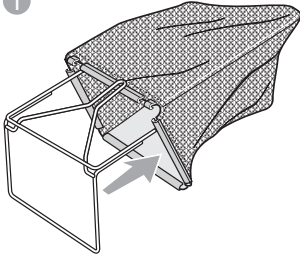

2

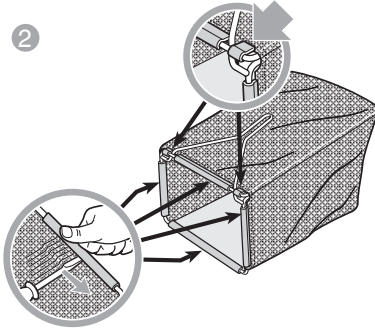

3

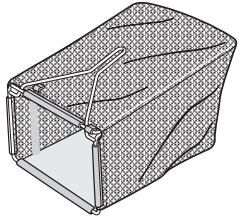

6

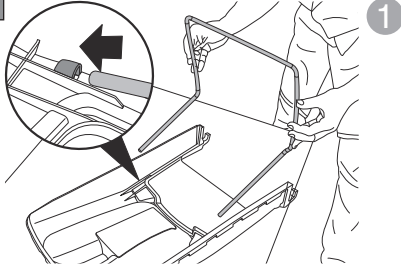

1

2

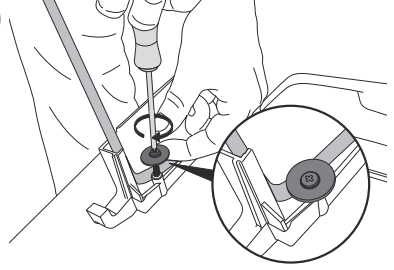

3

4

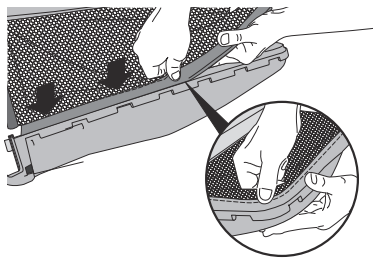
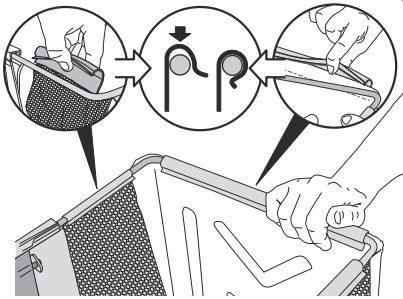

5

6

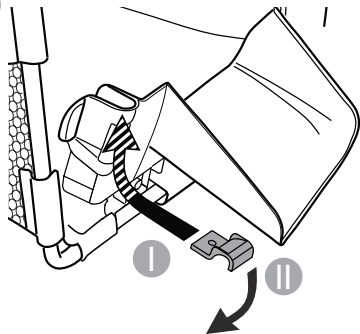
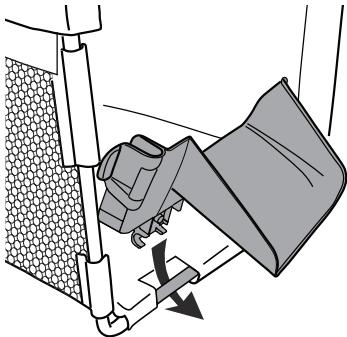

7

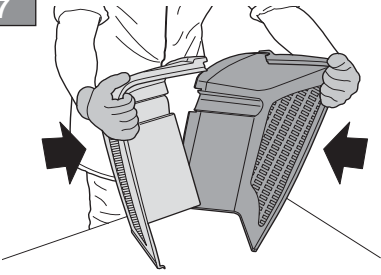

1

2

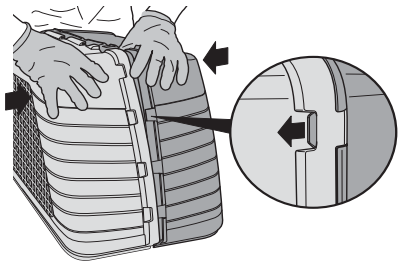

3

4

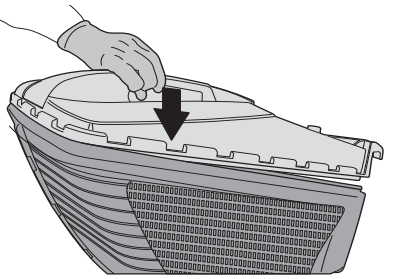
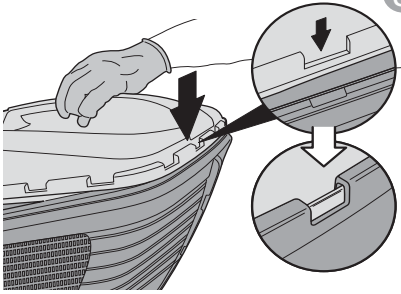

8

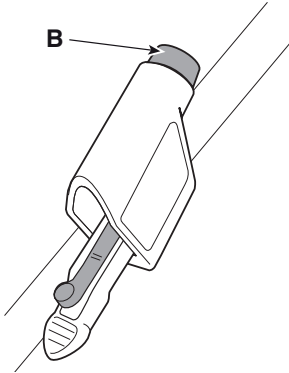
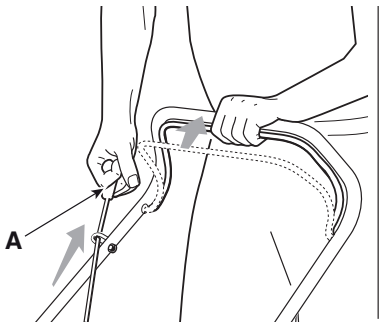

9

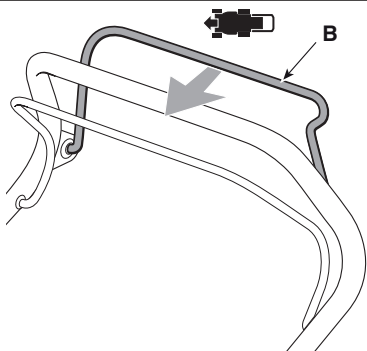
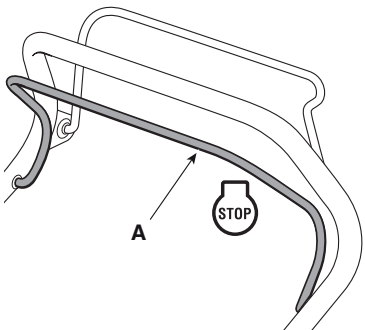

10

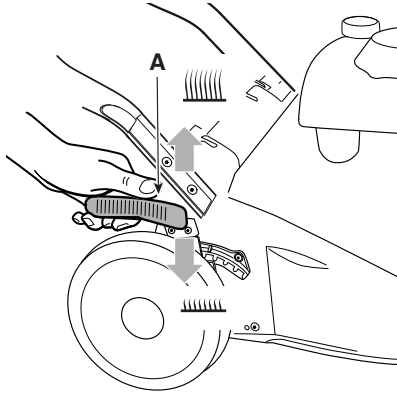

11

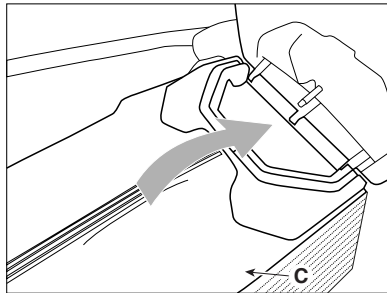
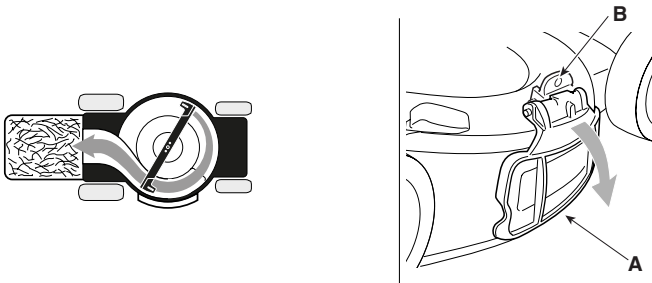

12

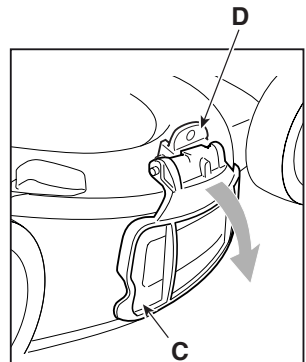
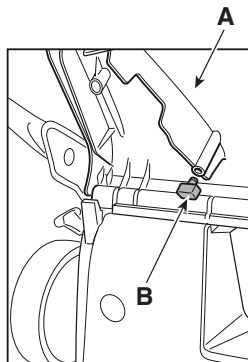
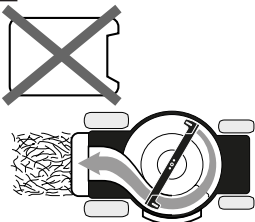



13

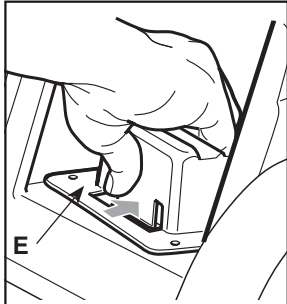
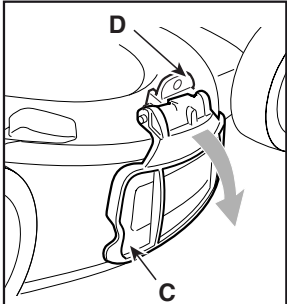
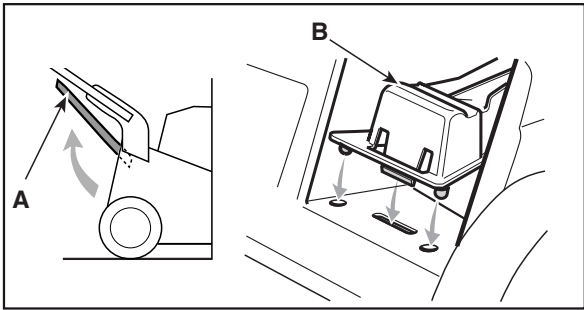

14

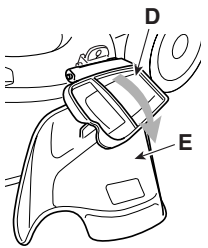
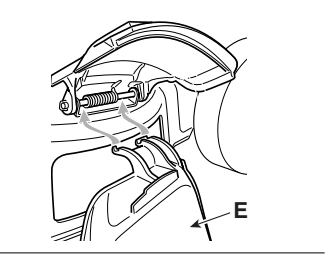
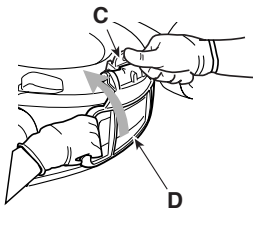
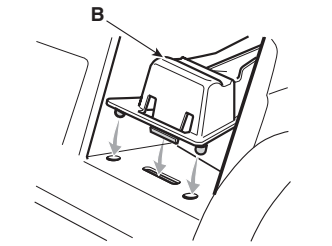
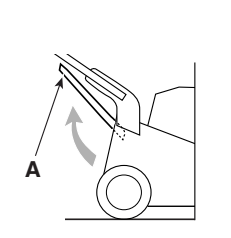

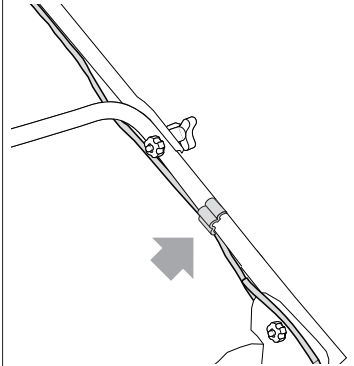
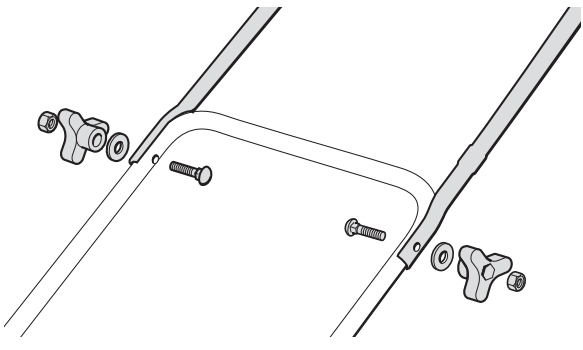
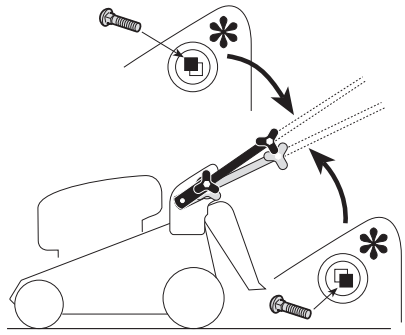
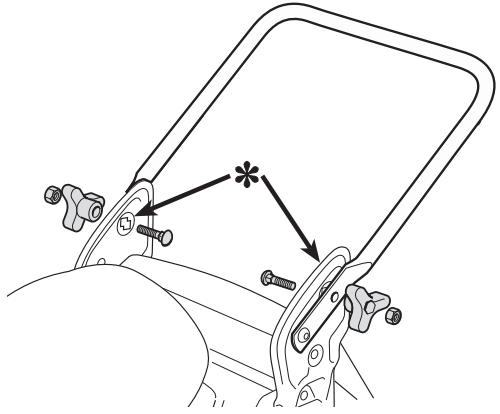
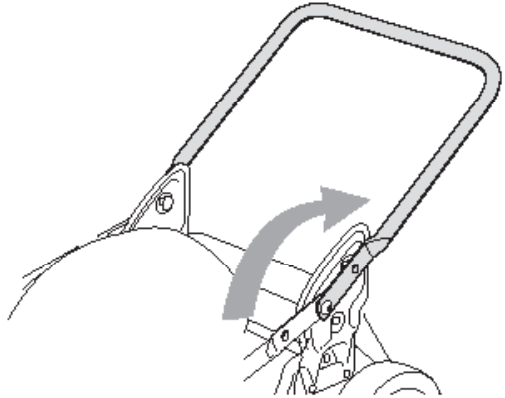

16

II

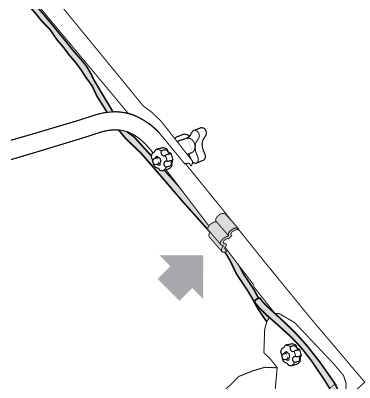
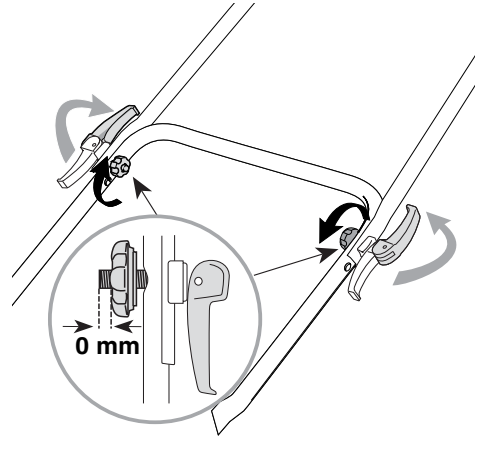
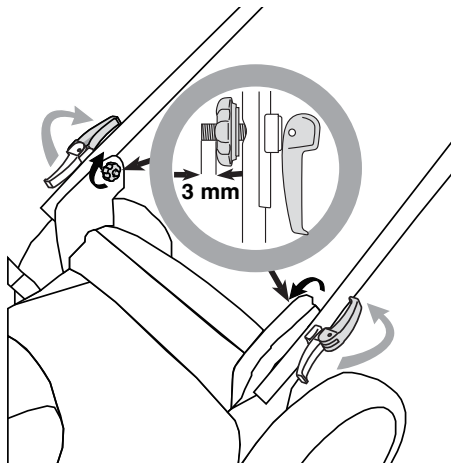
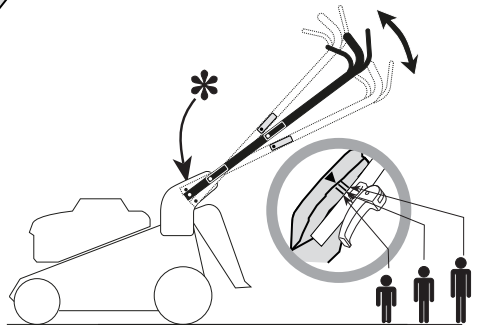
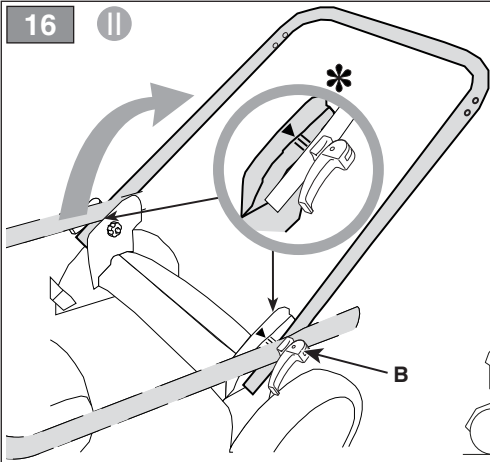

17

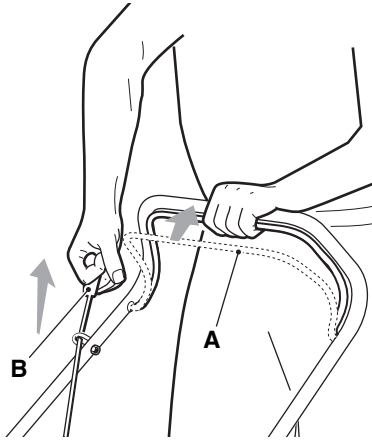

18

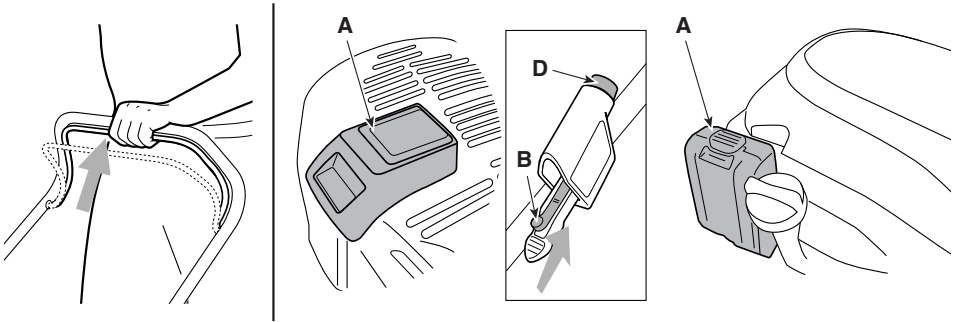

19

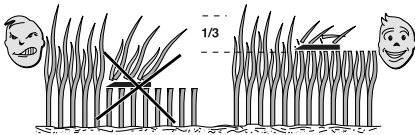

20

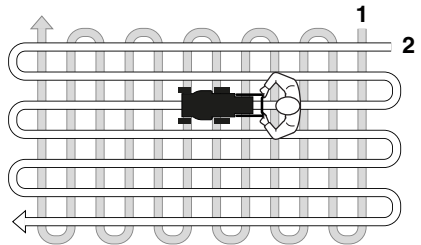

21

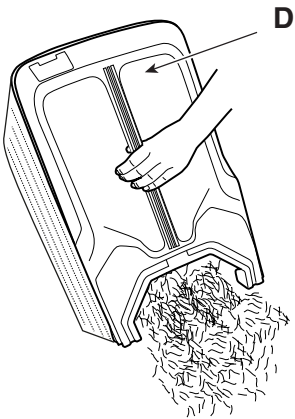
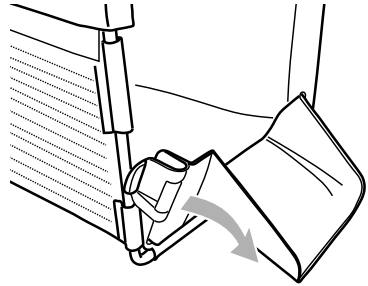
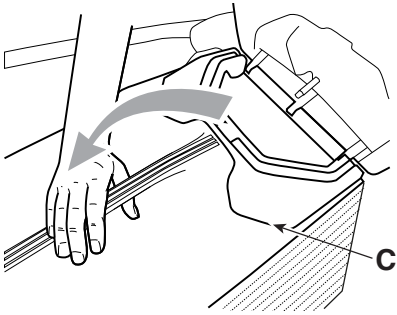
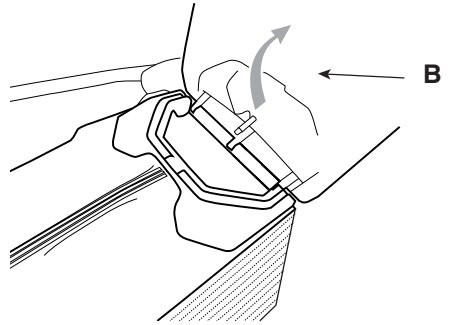
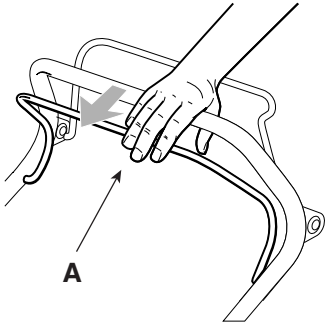

22

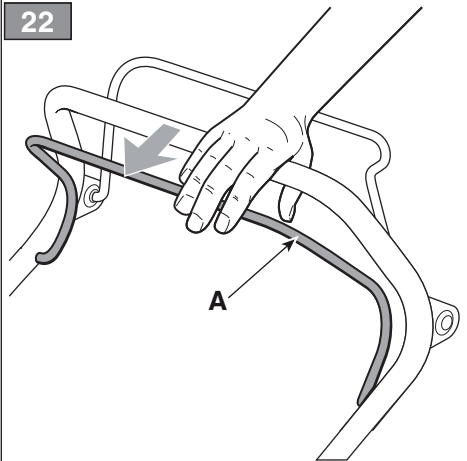

23

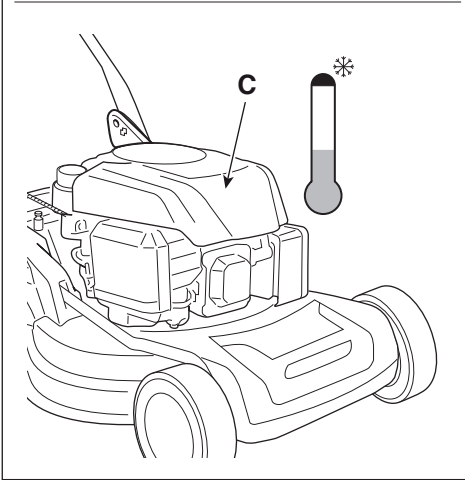
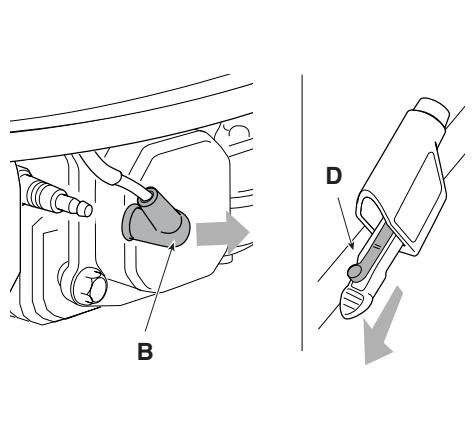
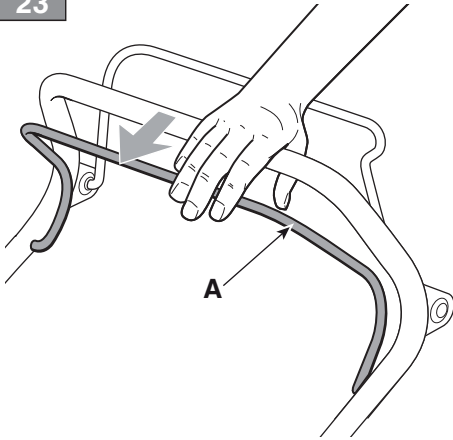

25

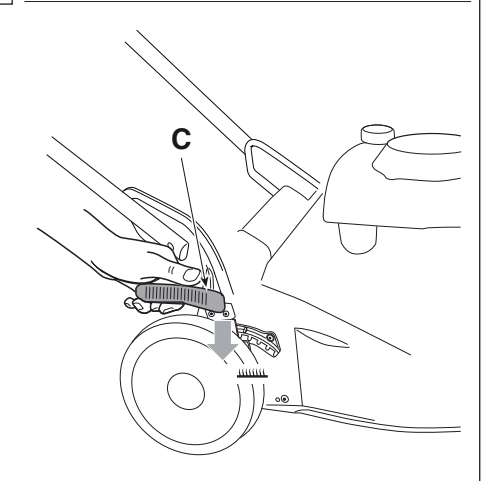
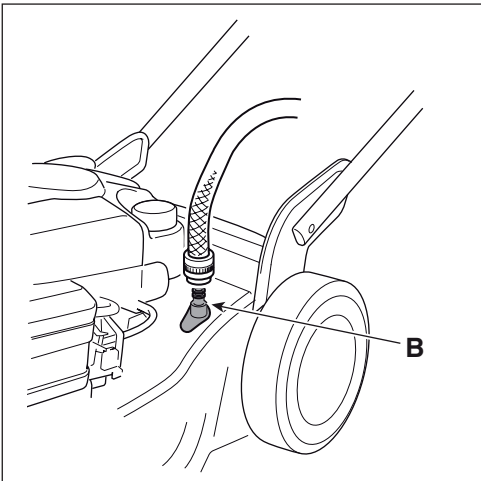
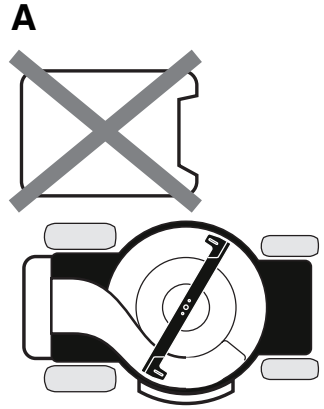

24

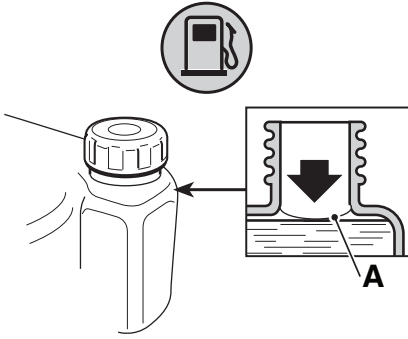

28



26

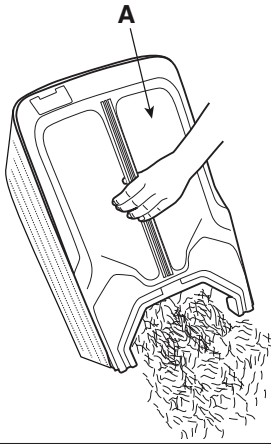

B

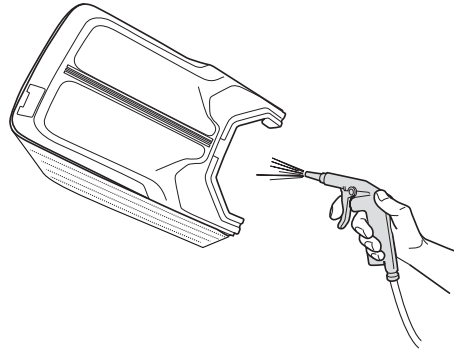

27

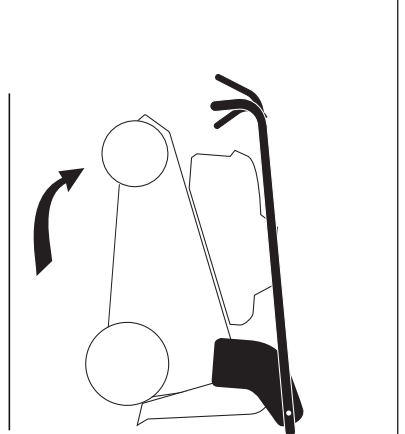
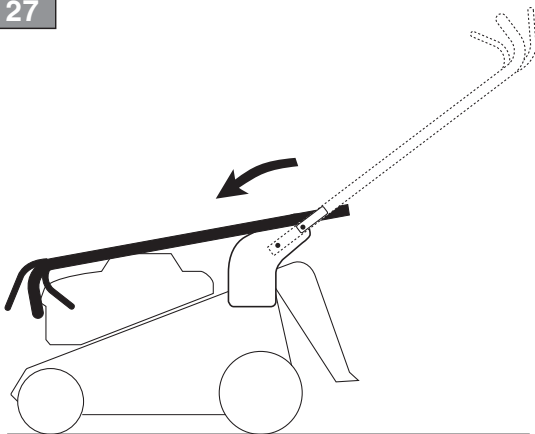

| [1]  | DATI TECNICI                                |                   | CP1 434 Series | CP1 484 Series           |
|------|---|-------------------|----------------|--------------------------|
| [2]  | Potenza nominale *                          | kW                | 1,75 ÷ 2,75    | 1,75 ÷ 3,3               |
| [3]  | Velocità mass. di funzionamento motore *    | min <sup>-1</sup> | 2900 ± 100     | 2900 ± 100               |
| [4]  | Peso macchina *                             | kg                | 22 ÷ 27        | 22 ÷ 32                  |
| [5]  | Ampiezza di taglio                          | cm                | 41             | 46                       |
| [6]  | Dimensioni:                                 |                   |                |                          |
| [6a] | Lunghezza                                   | cm                | 1580           | 1650                     |
| [6b] | Larghezza                                   | cm                | 540            | 560                      |
| [6c] | Altezza                                     | cm                | 1075           | 1075                     |
| [7]  | Codice dispositivo di taglio                |                   | 81004341/3     | 81004460/0<br>81004346/3 |
| [8]  | Livello di pressione acustica (max.)        | dB(A)             | 81             | 83                       |
| [9]  | Incertezza di misura                        | dB(A)             | 2,21           | 1,46                     |
| [10] | Livello di potenza acustica misurato (max.) | dB(A)             | 94             | 96                       |
| [9]  | Incertezza di misura                        | dB(A)             | 1,61           | 0,61                     |
| [11] | Livello di potenza acustica garantito       | dB(A)             | 95             | 96                       |
| [12] | Livello di vibrazioni (max.)                | m/s <sup>2</sup>  | 4              | 5,9                      |
| [9]  | Incertezza di misura                        | m/s <sup>2</sup>  | 2,48           | 1,82                     |

| [13] | ACCESSORI A RICHIESTA |   |   |
|------|-----------------------|---|---|
| [14] | Kit "Mulching"        | ✓ | ✓ |

| [15] | OPZIONI                     |  |  |
|------|-----------------------------|--|--|
| [16] | Rimessaggio verticale, mod. | <b>CP1 434 K</b><br><b>CP1 434 QK</b><br><b>CP1 434 SK</b><br><b>CP1 434 SQK</b> | <b>CP1 484 K</b><br><b>CP1 484 QK</b><br><b>CP1 484 SK</b><br><b>CP1 484 SQK</b><br><b>CP1 484 SVK</b><br><b>CP1 484 SVQK</b><br><b>CP1 484 SEK</b><br><b>CP1 484 SQEK</b><br><b>CP1 484 SVEK</b><br><b>CP1 484 SVEQK</b><br><b>CP1 484 WK</b><br><b>CP1 484 WQK</b><br><b>CP1 484 WSK</b><br><b>CP1 484 WSQK</b><br><b>CP1 484 WSVK</b><br><b>CP1 484 WSVQK</b><br><b>CP1 484 WSEK</b><br><b>CP1 484 WSQEK</b><br><b>CP1 484 WSVEK</b><br><b>CP1 484 WSVEQK</b> |

\* Per il dato specifico, fare riferimento a quanto indicato nell'etichetta di identificazione della macchina.



|   |   |   |
|---|---|---|
| <p>[1] <b>BG - ТЕХНИЧЕСКИ ДАННИ</b></p> <p>[2] Номинална мощност</p> <p>[3] Максимална скорост на работа на двигателя</p> <p>[4] Тегло на машината</p> <p>[5] Широчина на косене cm</p> <p>[6] Размери:</p> <p>[6a] Дължина cm</p> <p>[6b] Ширина cm</p> <p>[6c] Височина cm</p> <p>[7] Код на инструмента за рязане</p> <p>[8] Ниво на звуково налягане (max.)</p> <p>[9] Несигурност на измерване</p> <p>[10] Измерено ниво на акустична мощност (max.)</p> <p>[11] Гарантирано ниво на акустична мощност</p> <p>[12] Ниво на вибрации (max.)</p> <p>[13] ПРИНАДЛЕЖНОСТИ ПО ЗАЯВКА</p> <p>[14] Набор за "Mulching" (Раздробяване)</p> <p>[15] ОПЦИИ</p> <p>[16] Вертикално поставяне за съхранение</p> <p>* специфични данни, вижте посоченото на идентификационния етикет на машината.</p> | <p>[1] <b>BS - TEHNIČKI PODACI</b></p> <p>[2] Nazivna snaga</p> <p>[3] Maks. radna brzina motora</p> <p>[4] Težina mašine</p> <p>[5] Širina košenja cm</p> <p>[6] Dimenzije:</p> <p>[6a] Dužina cm</p> <p>[6b] Širina cm</p> <p>[6c] Visina cm</p> <p>[7] Šifra rezne glave</p> <p>[8] Razina zvučnog pritiska (max.)</p> <p>[9] Mjerna nesigurnost</p> <p>[10] Izmjerena razina zvučne snage (max.)</p> <p>[11] Garantovana razina zvučne snage</p> <p>[12] Razina vibracija (max.)</p> <p>[13] DODATNA OPREMA NA ZAHTJEV</p> <p>[14] Komplet za mulčiranje</p> <p>[15] OPCIJE</p> <p>[16] Odlaganje u vertikalnom položaju</p> <p>* Za određeni podatak pogledajte podatke navedene na identifikacijskoj etiketi mašine.</p>  | <p>[1] <b>CS - TECHNICKÉ PARAMETRY</b></p> <p>[2] Jmenovitý výkon</p> <p>[3] Maximální rychlost činnosti motoru</p> <p>[4] Hmotnost stroje</p> <p>[5] Šířka sečení v cm</p> <p>[6] Rozměry:</p> <p>[6a] Délka v cm</p> <p>[6b] Šířka v cm</p> <p>[6c] Výška v cm</p> <p>[7] Kód sekačičho zařízení</p> <p>[8] Úroveň akustického tlaku (max.)</p> <p>[9] Nepřesnost měření</p> <p>[10] Úroveň naměřené akustického výkonu (max.)</p> <p>[11] Úroveň zaručeného akustického výkonu</p> <p>[12] Úroveň vibrací (max.)</p> <p>[13] VOLITELNÁ PŘÍSLUŠENSTVÍ</p> <p>[14] Sada pro Mulčování</p> <p>[15] MOŽNOSTI</p> <p>[16] Skladování ve svislé poloze</p> <p>* Ohledně uvedeného údaje, vycházejte z hodnoty uvedené na identifikačním štítku stroje.</p>                                     |
| <p>[1] <b>DA - TEKNISKE DATA</b></p> <p>[2] Nominel effekt</p> <p>[3] Motorens maks. driftshastighed</p> <p>[4] Maskinens vægt</p> <p>[5] Klippebredde cm</p> <p>[6] Mål:</p> <p>[6a] Længde cm</p> <p>[6b] Bredde cm</p> <p>[6c] Højde cm</p> <p>[7] Skærearordningens varenr.</p> <p>[8] Lydtryksniveau (max.)</p> <p>[9] Usikkerhed ved målingen</p> <p>[10] Lydeffektniveau målt (max.)</p> <p>[11] Garanteret lydeffektniveau</p> <p>[12] Vibrationsniveau (max.)</p> <p>[13] TILBEHØR</p> <p>[14] Sæt til "Multiclip"</p> <p>[15] EKSTRAUDSTYR</p> <p>[16] Opbevaring i lodret position</p> <p>* For disse data henvises til hvad der er angivet på maskinens identifikationsmærkat.</p>  | <p>[1] <b>DE - TECHNISCHE DATEN</b></p> <p>[2] Nennleistung</p> <p>[3] Max. Betriebsgeschwindigkeit des Motors</p> <p>[4] Maschinengewicht</p> <p>[5] Schnittbreite cm</p> <p>[6] Abmessungen:</p> <p>[6a] Länge cm</p> <p>[6b] Breite cm</p> <p>[6c] Höhe cm</p> <p>[7] Code Schneidwerkzeug</p> <p>[8] Schalldruckpegel (max.)</p> <p>[9] Messungengenauigkeit</p> <p>[10] Gemessener Schalleistungspegel (max.)</p> <p>[11] Garantiertes Schalleistungspegel</p> <p>[12] Vibrationspegel (max.)</p> <p>[13] SONDERZUBEHÖR</p> <p>[14] "Mulching"-Kit</p> <p>[15] OPTIONEN</p> <p>[16] Senkrechte Lagerung</p> <p>* Für die genaue Angabe nehmen Sie bitte auf das Typenschild der Maschine Bezug.</p>  | <p>[1] <b>EL - ΤΕΧΝΙΚΑ ΧΑΡΑΚΤΗΡΙΣΤΙΚΑ</b></p> <p>[2] Ονομαστική ισχύς</p> <p>[3] Μέγ. ταχύτητα λειτουργίας κινητήρα</p> <p>[4] Βάρος μηχανήματος</p> <p>[5] Πλάτος κοπής cm</p> <p>[6] Διαστάσεις:</p> <p>[6a] Μήκος cm</p> <p>[6b] Πλάτος cm</p> <p>[6c] Ύψος cm</p> <p>[7] Κωδικός συστήματος κοπής</p> <p>[8] Στάθμη ακουστικής πίεσης (max.)</p> <p>[9] Αβεβαιότητα μέτρησης</p> <p>[10] Μετρημένη στάθμη ακουστικής ισχύος (max.)</p> <p>[11] Στάθμη εγγυώμενης ηχητικής ισχύος</p> <p>[12] Επίπεδο κραδασμών (max.)</p> <p>[13] ΠΡΟΑΙΡΕΤΙΚΑ ΑΞΕΣΟΥΑΡ</p> <p>[14] Σετ "Mulching" (ψιλοτεμαχισμού)</p> <p>[15] ΠΡΟΑΙΡΕΤΙΚΑ</p> <p>[16] Αποθήκευση σε κατακόρυφη θέση</p> <p>* Για το συγκεκριμένο στοιχείο, ελέγξτε τα όσα αναγράφονται στην ετικέτα προσδιορισμού του μηχανήματος.</p> |
| <p>[1] <b>EN - TECHNICAL DATA</b></p> <p>[2] Nominal power</p> <p>[3] Max. engine operation speed</p> <p>[4] Machine weight</p> <p>[5] Cutting width cm</p> <p>[6] Dimensions:</p> <p>[6a] Length cm</p> <p>[6b] Width cm</p> <p>[6c] Height cm</p> <p>[7] Cutting means code</p> <p>[8] Acoustic pressure level (max.)</p> <p>[9] Measurement uncertainty</p> <p>[10] Acoustic power level measured (max.)</p> <p>[11] Acoustic power level guaranteed</p> <p>[12] Vibration level (max.)</p> <p>[13] OPTIONAL ACCESSORIES</p> <p>[14] Mulching kit</p> <p>[15] OPTIONS</p> <p>[16] Vertical storage</p> <p>* Please refer to the data indicated on the machine's identification plate for the exact figure.</p>   | <p>[1] <b>ES - DATOS TÉCNICOS</b></p> <p>[2] Potencia nominal</p> <p>[3] Velocidad máx. de funcionamiento motor</p> <p>[4] Peso máquina</p> <p>[5] Amplitud de corte cm</p> <p>[6] Dimensiones:</p> <p>[6a] Longitud cm</p> <p>[6b] Anchura cm</p> <p>[6c] Altura cm</p> <p>[7] Código dispositivo de corte</p> <p>[8] Nivel de presión acústica (max.)</p> <p>[9] Incertidumbre de medida</p> <p>[10] Nivel de potencia acústica medido (max.)</p> <p>[11] Nivel de potencia acústica garantizado</p> <p>[12] Nivel de vibraciones (max.)</p> <p>[13] ACCESORIOS POR ENCARGO</p> <p>[14] Kit para "Mulching"</p> <p>[15] OPCIONES</p> <p>[16] Almacenaje vertical</p> <p>* Para el dato específico, hacer referencia a lo indicado en la etiqueta de identificación de la máquina.</p> | <p>[1] <b>ET - TEHNILISED ANDMED</b></p> <p>[2] Nominaalvõimsus</p> <p>[3] mootori töötamise maks. kiirus</p> <p>[4] Masina mass</p> <p>[5] Lõikelaius cm</p> <p>[6] Mõõtmel:</p> <p>[6a] Pikkus cm</p> <p>[6b] Laius cm</p> <p>[6c] Kõrgus cm</p> <p>[7] Lõikesaadme kood</p> <p>[8] Helirõhu tase (max.)</p> <p>[9] Mõõtemääramatus</p> <p>[10] Mõõdetud müravõimsuse tase (max.)</p> <p>[11] Garanteeritud müravõimsuse tase</p> <p>[12] Vibratsioonide tase (max.)</p> <p>[13] LISASEADMED TELLIMISEL</p> <p>[14] "Multisim" komplekt</p> <p>[15] VALIKUD</p> <p>[16] Vertikaalne hoiulepanek</p> <p>* Konkreetse info jaoks viidata masina identifitseerimisetiketil märgitule</p>   |

|  |  |  |
|--|--|--|
| <p>[1] <b>FI - TEKNISET TIEDOT</b></p> <p>[2] Nimellisteho</p> <p>[3] Moottorin maksimaalinen toimintanopeus</p> <p>[4] Laitteen paino</p> <p>[5] Leikkuleveys cm</p> <p>[6] Mitat:</p> <p>[6a] Pituus cm</p> <p>[6b] Leveys cm</p> <p>[6c] Korkeus cm</p> <p>[7] Leikkuvälineen koodi</p> <p>[8] Akustisen paineen taso (max.)</p> <p>[9] Mittausepävarmuus</p> <p>[10] Mitattu melutaso (max.)</p> <p>[11] Taattu äänitehotaso</p> <p>[12] Tärinätaso (max.)</p> <p>[13] SAATAVANA OLEVAT LISÄVARUSTEET</p> <p>[14] Silppuamisarusteet</p> <p>[15] VALINNAT</p> <p>[16] Varastointi pystysuunnassa</p> <p>* Määrättyä arvoa varten, viittaa laitteen tunnuslaatassa annettuihin tietoihin.</p>   | <p>[1] <b>FR - CARACTÉRISTIQUES TECHNIQUES</b></p> <p>[2] Puissance nominale</p> <p>[3] Vitesse max de fonctionnement moteur</p> <p>[4] Poids de la machine</p> <p>[5] Largeur de coupe cm</p> <p>[6] Dimensions:</p> <p>[6a] Longueur cm</p> <p>[6b] Largeur cm</p> <p>[6c] Hauteur cm</p> <p>[7] Code organe de coupe</p> <p>[8] Niveau de pression acoustique (max.)</p> <p>[9] Incertitude de mesure</p> <p>[10] Niveau de puissance acoustique mesuré (max.)</p> <p>[11] Niveau de puissance acoustique garanti</p> <p>[12] Niveau de vibrations (max.)</p> <p>[13] EQUIPEMENTS SUR DEMANDE</p> <p>[14] Kit "Mulching"</p> <p>[15] OPTIONS</p> <p>[16] Entreposage vertical</p> <p>* Pour la valeur spécifique, se référer à ce qui est indiqué sur la plaque signalétique de la machine.</p> | <p>[1] <b>HR - TEHNIČKI PODACI</b></p> <p>[2] Nazivna snaga</p> <p>[3] Maks. brzina rada motora</p> <p>[4] Težina stroja</p> <p>[5] Širina košnje cm</p> <p>[6] Dimenzije:</p> <p>[6a] Dužina cm</p> <p>[6b] Širina cm</p> <p>[6c] Visina cm</p> <p>[7] Šifra noža</p> <p>[8] Razina zvučnog tlaka (max.)</p> <p>[9] Mjerna nesigurnost</p> <p>[10] Izmjerena razina zvučne snage (max.)</p> <p>[11] Zajamčena razina zvučne snage</p> <p>[12] Razina vibracija (max.)</p> <p>[13] DODATNA OPREMA PO NARUDŽBI</p> <p>[14] Komplet za "malčiranje"</p> <p>[15] OPCIJE</p> <p>[16] Okomito skladištenje</p> <p>* Specifični podatak pogledajte na identifikacijskoj etiketi stroja.</p>  |
| <p>[1] <b>HU - MŰSZAKI ADATOK</b></p> <p>[2] Néveleges teljesítmény</p> <p>[3] A motor max. üzemi sebessége</p> <p>[4] A gép tömege</p> <p>[5] Munkaszélesség</p> <p>[6] Méretek</p> <p>[6a] Hosszúság cm</p> <p>[6b] Szélesség cm</p> <p>[6c] Magasság cm</p> <p>[7] Vágóegység kódszáma</p> <p>[8] Hangnyomásszint (max.)</p> <p>[9] Mérési bizonytalanság</p> <p>[10] Mért zajteljesítmény szint (max.)</p> <p>[11] Garantált zajteljesítmény szint</p> <p>[12] Vibrációs szint (max.)</p> <p>[13] RENDELHETŐ KIEGÉSZÍTŐK</p> <p>[14] "Mulcsozó" készlet</p> <p>[15] OPCIÓK</p> <p>[16] Függőleges tárolás</p> <p>* A pontos adatot lásd a gép azonosító adattábláján.</p>  | <p>[1] <b>LT - TECHINIAI DUOMENYS</b></p> <p>[2] Vardinė galia</p> <p>[3] Maksimalus variklio darbo greitis</p> <p>[4] Įrenginio svoris</p> <p>[5] Pjovimo plotis, cm</p> <p>[6] Matmenys:</p> <p>[6a] Ilgis, cm</p> <p>[6b] Plotis, cm</p> <p>[6c] Aukštis, cm</p> <p>[7] Pjovimo įtaiso kodas</p> <p>[8] Garso slėgio lygis (max.)</p> <p>[9] Matavimo paklaida</p> <p>[10] Išmatuotas garso galios lygis (max.)</p> <p>[11] Garantuotas garso galios lygis</p> <p>[12] Vibracijų lygis (max.)</p> <p>[13] UŽSAKOMI PRIEDAI</p> <p>[14] Mulčiavimo rinkinys</p> <p>[15] PASIRENKAMI PRIEDAI</p> <p>[16] Vertikalus sandėliavimas</p> <p>* Konkretūs specifiniai duomenys yra pateikti įrenginio identifikavimo etiketeje.</p>  | <p>[1] <b>LV - TEHNISKIE DATI</b></p> <p>[2] Nominālā jauda</p> <p>[3] Maks. dzinēja griešanās ātrums</p> <p>[4] Mašīnas svars</p> <p>[5] Pļaušanas platums (cm)</p> <p>[6] Izmēri:</p> <p>[6a] Garums (cm)</p> <p>[6b] Platums (cm)</p> <p>[6c] Augstums (cm)</p> <p>[7] Griezējierīces kods</p> <p>[8] Skaņas spiediena līmenis (max.)</p> <p>[9] Mērījumu kļūda</p> <p>[10] Izmērītāis skaņas intensitātes līmenis (max.)</p> <p>[11] Garantētais skaņas intensitātes līmenis</p> <p>[12] Vibrāciju līmenis (max.)</p> <p>[13] PIEDERUMI PĒC PASŪTĪJUMA</p> <p>[14] "Mulčēšanas" komplekts</p> <p>[15] PAPILDAPRĪKOJUMS</p> <p>[16] Glabāšana vertikālā stāvoklī</p> <p>* Precīza vērtība ir norādīta mašīnas identifikācijas datu plāksnītē.</p> |
| <p>[1] <b>МК - ТЕХНИЧКИ ПОДАТОЦИ</b></p> <p>[2] Номинална мојност</p> <p>[3] Максимална брзина на работа на моторот</p> <p>[4] Тежина на машината</p> <p>[5] Обем на косење во см</p> <p>[6] Димензии:</p> <p>[6a] Должина во см</p> <p>[6b] Ширина во см</p> <p>[6c] Висина см</p> <p>[7] Код на уредот со сечивото</p> <p>[8] Ниво на акустичен притисок (max.)</p> <p>[9] Отстапување при мерење</p> <p>[10] Измерено ниво на акустична мојност (max.)</p> <p>[11] Гарантирано ниво на акустична мојност</p> <p>[12] Ниво на вибрации (max.)</p> <p>[13] ДОПОЛНИТЕЛНА ОПРЕМА НА БАРАЊЕ</p> <p>[14] Комплет за "мелење"</p> <p>[15] ОПЦИИ</p> <p>[16] Вертикално складирање</p> <p>* За даден податок, проверете дали истиот е посочен на етикетата за идентификација на машината.</p> | <p>[1] <b>NL - TECHNISCHE GEGEVENS</b></p> <p>[2] Nominiaal vermogen</p> <p>[3] Maximale snelheid voor de werking van de motor</p> <p>[4] Machine gewicht</p> <p>[5] Maatbreedte cm</p> <p>[6] Afmetingen:</p> <p>[6a] Lengte cm</p> <p>[6b] Breedte cm</p> <p>[6c] Hoogte cm</p> <p>[7] Code snij-richting</p> <p>[8] Niveau geluidsdruk (max.)</p> <p>[9] Meetonzekerheid</p> <p>[10] Gemeten akoestisch vermogen (max.)</p> <p>[11] Gewaarborgd akoestisch vermogen</p> <p>[12] Niveau trillingen (max.)</p> <p>[13] OP AANVRAAG LEVERBARE ACCESSOIRES</p> <p>[14] Kit "Mulching"</p> <p>[15] OPTIES</p> <p>[16] Verticale opslag</p> <p>* Voor specifiek gegeven, verwijst men naar wat aangegeven is op het identificatielabel van de machine.</p>  | <p>[1] <b>NO - TEKNISKE DATA</b></p> <p>[2] Nominell effekt</p> <p>[3] Motorens maks driftshastighet</p> <p>[4] Maskinvekt</p> <p>[5] Klippebredde cm</p> <p>[6] Mål:</p> <p>[6a] Lengde cm</p> <p>[6b] Bredde cm</p> <p>[6c] Høyde cm</p> <p>[7] Artikkelnnummer for klippeinnretning</p> <p>[8] Lydtrykknivå (max.)</p> <p>[9] Måleusikkerhet</p> <p>[10] Målt lyd effektktivnivå (max.)</p> <p>[11] Garantert lyd effektktivnivå</p> <p>[12] Vibrasjonsnivå (max.)</p> <p>[13] TILBEHØR PÅ FORESPØRSEL</p> <p>[14] Mulching-sett</p> <p>[15] EKSTRAUTSTYR</p> <p>[16] Lagring i loddrett posisjon</p> <p>* For spesifik informasjon, se referansen på maskinens identifikasjonsetikett.</p>   |

|   |  |   |
|---|--|---|
| <p>[1] <b>PL - DANE TECHNICZNE</b></p> <p>[2] Moc znamionowa</p> <p>[3] Maks. prędkość obrotowa silnika</p> <p>[4] Ciężar maszyny</p> <p>[5] Szerokość koszenia w cm</p> <p>[6] Wymiary:</p> <p>[6a] Długość w cm</p> <p>[6b] Szerokość w cm</p> <p>[6c] Wysokość w cm</p> <p>[7] Kod agregatu tnącego</p> <p>[8] Poziom ciśnienia akustycznego (max.)</p> <p>[9] Błąd pomiaru</p> <p>[10] Zmierzony poziom mocy akustycznej (max.)</p> <p>[11] Gwarantowany poziom mocy akustycznej</p> <p>[12] Poziom wibracji (max.)</p> <p>[13] AKCESORIA NA ZAMÓWIENIE</p> <p>[14] Zestaw do "Mulczowania"</p> <p>[15] OPCJE</p> <p>[16] Przechowywanie w pozycji pionowej</p> <p>* W celu uzyskania konkretnych danych, należy się odnieść do wskazówek zamieszczonych na tabliczce identyfikacyjnej maszyny.</p> | <p>[1] <b>PT - DADOS TÉCNICOS</b></p> <p>[2] Potência nominal</p> <p>[3] Velocidade máx. de funcionamento do motor</p> <p>[4] Peso da máquina</p> <p>[5] Amplitude de corte cm</p> <p>[6] Medidas:</p> <p>[6a] Comprimento cm</p> <p>[6b] Largura cm</p> <p>[6c] Altura cm</p> <p>[7] Código do dispositivo de corte</p> <p>[8] Nivel de pressão acústica (max.)</p> <p>[9] Incerteza de medição</p> <p>[10] Nivel de potência acústica medido (max.)</p> <p>[11] Nivel de potência acústica garantido</p> <p>[12] Nivel de vibrações (max.)</p> <p>[13] ACESSÓRIOS A PEDIDO</p> <p>[14] Kit "Mulching"</p> <p>[15] OPÇÕES</p> <p>[16] Armazenagem vertical</p> <p>* Para o dado específico, consulte a etiqueta de identificação da máquina.</p>              | <p>[1] <b>RO - DATE TEHNICE</b></p> <p>[2] Putere nominală</p> <p>[3] Viteză max. de funcționare a motorului</p> <p>[4] Greutatea mașinii</p> <p>[5] Lățimea de tăiere cm</p> <p>[6] Dimensiuni:</p> <p>[6a] Lungime cm</p> <p>[6b] Lățime cm</p> <p>[6c] Înălțime cm</p> <p>[7] Codul dispozitivului de tăiere</p> <p>[8] Nivel de presiune acustică (max.)</p> <p>[9] Nesiguranta în măsurare</p> <p>[10] Nivel de putere acustică măsurat (max.)</p> <p>[11] Nivel de putere acustică garantat</p> <p>[12] Nivel de vibrații (max.)</p> <p>[13] ACCESORII LA CERERE</p> <p>[14] Kit de măruntire „Mulching”</p> <p>[15] OPȚIUNI</p> <p>[16] Depozitare verticală</p> <p>* Pentru informația specifică, consultați datele de pe eticheta de identificare a mașinii.</p> |
| <p>[1] <b>RU - ТЕХНИЧЕСКИЕ ХАРАКТЕРИСТИКИ</b></p> <p>[2] Номинальная мощность</p> <p>[3] Макс. скорость работы двигателя</p> <p>[4] Вес машины</p> <p>[5] Ширина скашивания в см</p> <p>[6] Габариты:</p> <p>[6a] Длина в см</p> <p>[6b] Ширина в см</p> <p>[6c] Высота в см</p> <p>[7] Код режущего приспособления</p> <p>[8] Уровень звукового давления (max.)</p> <p>[9] Погрешность измерения</p> <p>[10] Измеренный уровень звуковой мощности (max.)</p> <p>[11] Гарантируемый уровень звуковой мощности</p> <p>[12] Уровень вибрации (max.)</p> <p>[13] ДОПОЛНИТЕЛЬНОЕ ОБОРУДОВАНИЕ ПО ТРЕБОВАНИЮ</p> <p>[14] Комплект "Мульчирование"</p> <p>[15] ОПЦИИ</p> <p>[16] Хранение в вертикальном положении</p> <p>* Точное значение см. на идентификационном ярлыке машины.</p>                       | <p>[1] <b>SK - TECHNICKÉ PARAMETRE</b></p> <p>[2] Menovitý výkon</p> <p>[3] Maximálna rýchlosť motora</p> <p>[4] Hmotnosť stroja</p> <p>[5] Šírka kosenia v cm</p> <p>[6] Rozmery:</p> <p>[6a] Dĺžka v cm</p> <p>[6b] Šírka v cm</p> <p>[6c] Výška v cm</p> <p>[7] Kód kosacieho zariadenia</p> <p>[8] Úroveň akustického tlaku (max.)</p> <p>[9] Nepresnosť merania</p> <p>[10] Úroveň nameraného akustického výkonu (max.)</p> <p>[11] Úroveň zarúčeného akustického výkonu</p> <p>[12] Úroveň vibrácií (max.)</p> <p>[13] VOLITELNÉ PRÍSLUŠENSTVO</p> <p>[14] Súprava na mulčovanie</p> <p>[15] MOŽNOSTI</p> <p>[16] Uskladnenie vo zvislej polohe</p> <p>* Ohľadne uvedeného parametra vychádzajte z hodnoty uvedenej na identifikačnom štítku stroja.</p> | <p>[1] <b>SL - TEHNIČNI PODATKI</b></p> <p>[2] Nazivna moč</p> <p>[3] Najvišja hitrost delovanja motorja</p> <p>[4] Teža stroja</p> <p>[5] Širina reza cm</p> <p>[6] Dimenzije:</p> <p>[6a] Dolžina cm</p> <p>[6b] Širina cm</p> <p>[6c] Višina cm</p> <p>[7] Šifra rezalne naprave</p> <p>[8] Raven zvočnega tlaka (max.)</p> <p>[9] Nezanesljivost meritve</p> <p>[10] Izmerjena raven zvočne moči (max.)</p> <p>[11] Zajamčena raven zvočne moči</p> <p>[12] Nivo vibracij (max.)</p> <p>[13] DODATNI OPREMA PO NAROČILU</p> <p>[14] Komplet za mulčenje</p> <p>[15] OPCIJE</p> <p>[16] Shranjevanje v pokončnem položaju</p> <p>* Za specifični podatek glej identifikacijsko nalepko stroja.</p>   |
| <p>[1] <b>SR - TEHNIČKI PODACI</b></p> <p>[2] Nazivna snaga</p> <p>[3] Maks. radna brzina motora</p> <p>[4] Težina mašine</p> <p>[5] Širina košenja u cm</p> <p>[6] Dimenzije:</p> <p>[6a] Dužina u cm</p> <p>[6b] Širina u cm</p> <p>[6c] Visina u cm</p> <p>[7] Šifra rezne glave</p> <p>[8] Nivo zvučnog pritiska (max.)</p> <p>[9] Merna nesigurnost</p> <p>[10] Izmereni nivo zvučne snage (max.)</p> <p>[11] Garantovani nivo zvučne snage</p> <p>[12] Nivo vibracija (max.)</p> <p>[13] DODATNI PRIBOR PO NARUDŽBINI</p> <p>[14] Komplet za malčiranje</p> <p>[15] OPCIJE</p> <p>[16] Odlaganje u vertikalnom položaju</p> <p>* Za specifični podatak, pogledajte podatke navedene na identifikacijskoj nalepnici mašine.</p>  | <p>[1] <b>SV - TEKNISKA SPECIFIKATIONER</b></p> <p>[2] Nominell effekt</p> <p>[3] Motorns maximala funktionshastighet</p> <p>[4] Maskinvikt</p> <p>[5] Skärbredd</p> <p>[6] Dimensioner:</p> <p>[6a] Längd cm</p> <p>[6b] Bredd cm</p> <p>[6c] Höjd cm</p> <p>[7] Skärenhetens kod</p> <p>[8] Ljudtrycksnivå (max.)</p> <p>[9] Tvivel med mått</p> <p>[10] Uppmätt ljudeffektivitet (max.)</p> <p>[11] Garanterad ljudeffektivitet</p> <p>[12] Vibrationsnivå (max.)</p> <p>[13] TILLBEHÖR PÅ BESTÄLLNING</p> <p>[14] Komplet za malčiranje</p> <p>[15] TILLVAL</p> <p>[16] Vertikal förvaring</p> <p>* För specifik information, se uppgifterna på maskinens märklåt.</p>   | <p>[1] <b>TR - TEKNİK VERİLER</b></p> <p>[2] Nominal güç</p> <p>[3] Motorun maksimum çalıřma hızı</p> <p>[4] Makine ağırlığı</p> <p>[5] Kesim genişliđi, cm</p> <p>[6] Ebatlar:</p> <p>[6a] Uzunluk, cm</p> <p>[6b] Genişlik, cm</p> <p>[6c] Yükseklik, cm</p> <p>[7] Kesim düzeni kodu</p> <p>[8] Ses basınç seviyesi (max.)</p> <p>[9] Ölçü belirsizliđi</p> <p>[10] Ölçülen ses gücü seviyesi (max.)</p> <p>[11] Garanti edilen ses gücü seviyesi</p> <p>[12] Titreşim seviyesi (max.)</p> <p>[13] TALEP ÜZERİNE TEDARİK EDİLEN AKSESUARLAR</p> <p>[14] "Malçlama" kiti</p> <p>[15] SEÇENEKLER</p> <p>[16] Dikey saklama</p> <p>* Spesifik değer için, makine belirleme etiketinde belirtilenler referans alın</p>   |



## INDEX

|                                      |   |
|--------------------------------------|---|
| 1. GENERAL INFORMATION .....         | 1 |
| 2. SAFETY REGULATIONS .....          | 1 |
| 3. GETTING TO KNOW THE MACHINE.....  | 3 |
| 4. ASSEMBLY.....                     | 4 |
| 5. CONTROLS.....                     | 4 |
| 6. USING THE MACHINE.....            | 4 |
| 7. MAINTENANCE.....                  | 5 |
| 8. STORAGE.....                      | 6 |
| 9. HANDLING AND TRANSPORTATION ..... | 6 |
| 12. ATTACHMENTS ON REQUEST .....     | 7 |

### 1. GENERAL INFORMATION

#### 1.1 HOW TO READ THE MANUAL

Some paragraphs in the manual contain important information regarding safety and operation and are emphasised in this manner:

**NOTE OR IMPORTANT** *these give details or further information on what has already been said, and aim to prevent damage to the machine.*

This  symbol highlights danger. Failure to observe the warning can lead to possible personal and/or third party injury and/or damage.

- The paragraphs highlighted in a square with grey spots indicate the optional characteristics not on all models documented in this manual. Check if the characteristics are available on this model.

Whenever reference is made to a position on the machine "front", "back", "left" or "right" hand side, this refers to the operator's driving position.

#### 1.2 REFERENCES

##### 1.2.1 Figures

The figures in these instructions for use are numbered 1, 2, 3, etc.

The components indicated in the figures are identified with letters A, B, C, and so on.

Reference to component C in figure 2 is indicated with the wording: "See fig. 2.C" or simply "(Fig. 2.C)".

The figures are given as a guide only. The actual pieces can differ from those illustrated in this document.

##### 1.2.2 Titles

The manual is divided into chapters and paragraphs. The title of paragraph "2.1 Training" is a sub-title of "2. Safety regulations". References to titles or paragraphs are marked with the abbreviation chap. or par. and the relevant number. Example: "chap. 2" or "par. 2.1"

### 2. SAFETY REGULATIONS

#### 2.1 TRAINING

 **Become acquainted with the controls and the proper use of the machine. Learn how to stop the motor quickly. Failure to follow the warnings and instructions may result in fire and/or serious injury.**

- Never allow children or persons unfamiliar with these instructions to use the machine. Local laws may establish a minimum age for users.
- Never use the machine if the user is tired or unwell, or has taken medicine, drugs, alcohol or any substances which may slow their reflexes and compromise his judgement.
- Do not allow children or other passengers to ride on the machine.
- Bear in mind that the operator or user is responsible for accidents or unexpected events occurring to other people or their property. It is the user's responsibility to assess the potential risk of the area where work is to be carried out and to take all the necessary precautions to ensure his own safety and that of others, particularly on slopes or rough, slippery and unstable ground.
- If the machine is sold or lent to others, make sure that the operator reads the user instructions contained in this manual.

#### 2.2 PRELIMINARY PROCEDURES

##### Personal Protective Equipment (PPE)

- Always wear suitable work attire, hard-wearing safety footwear with non-slip soles and long trousers. Do not operate the machine barefoot or wearing open sandals. Wear hearing protection devices.
- Use of hearing protections can reduce the ability to hear any warnings (shouting or alarms). Be careful of what occurs around you in the work area.
- Wear protective gloves whenever your hands are at risk.
- Never wear scarves, shirts, necklaces, bracelets, loose flowing clothing, laces or ties or any hanging or flapping accessory that could catch in the machine or in any objects or materials in the work area.
- Tie your hair back if it is long.

##### Work area/Machine

- Thoroughly inspect the entire work area and remove anything that could be thrown by the machine or damage the cutting means/rotating units (stones, branches, iron wire, bones, etc.).

##### Internal combustion engine: fuel

-  **DANGER!** The fuel is highly flammable.
- Keep the fuel in approved containers, in a safe place, away from any naked lights or heat sources.
- Keep the containers free of residues of grass, leaves or excessive grease.
- Keep the containers out of the reach of children.
- Do not smoke when filling up with fuel or when handling the fuel.
- Use a funnel to top up with fuel only in the open air.
- Do not inhale fuel fumes.
- Never remove the tank cap or add fuel while the engine is running or when the engine is hot.
- Open the fuel tank slowly to allow the pressure inside to decrease gradually.
- Do not approach the tank opening with a naked flame to check its contents.
- In case of fuel leakages, do not attempt to start the engine but move the machine away from the area of spillage and avoid creating any source of ignition until the fuel has evaporated and fuel vapours have dissipated.
- Immediately clean up all traces of fuel spilt on the machine or on the ground.

- Replace caps of all fuel tanks and containers securely.
- Never start the machine in the same place in which you refuelled it with fuel; the engine must be started in an area at least 3 metres from where you refuelled.
- Avoid getting any fuel or your clothing and, if this should happen, change your clothes before starting the engine.

## 2.3 DURING OPERATION

### Work Area

- Do not operate the engine in confined spaces where dangerous carbon monoxide fumes can collect. The start-up operations must be carried out outdoors or in a well-ventilated area. Always remember that the exhaust gases are toxic.
- When starting up the machine, do not direct the silencer and therefore the exhaust fumes towards flammable materials.
- Do not use the machine in environments at risk of explosion, in the presence of flammable liquids, gas or powder. Power tools create sparks which may ignite the dust or fumes.
- Work only in daylight or with good artificial light in good visibility conditions.
- Keep persons, children and animals away from the working area. Children must be supervised by another adult.
- Avoid working with wet grass, in the rain and when there is a risk of a thunderstorm, especially lightening.
- Pay careful attention to uneven ground (hills, dips), slopes, hidden hazards and obstacles that could limit visibility.
- Be very careful near ravines, ditches or embankments. The machine could overturn if a wheel slides over the edge or if the earth gives way.
- Always mow across a slope and never up and down it, being very careful when changing direction, making sure you have firm footing and that the wheels do not hit any obstacles (such as stones, branches, roots, etc.) that may cause the machine to slide sideways or make you lose control of it.
- Look out for traffic when using the machine near the road.
- To avoid the risk of fire, do not leave the machine with the engine hot on leaves or dry grass or other flammable material.

### Behaviour

- Exercise caution when reversing or moving backwards. Look behind you to make sure there are no obstacles before and during operations in reverse gear.
- Never run, always walk.
- Do not allow the lawnmower to pull you along.
- Always keep hands and feet away from the cutting means, when starting and when using the machine.
- Attention: the cutting means will continue to rotate for a few seconds after disengagement or after you have switched off the motor.
- Keep away from the discharge opening.
- Do not touch the parts of the engine that heat up during operation. Risk of burns.

**⚠ If something breaks or an accident occurs during mowing, turn off the motor immediately and move the machine away to prevent further damage; if an accident occurs with injuries or third parties are injured, carry out the first aid measures most suitable for the situation immediately and contact the medical authorities for any necessary health care. Carefully remove any debris which could cause damage or injury to persons or animals if ignored.**

### Use limitations

- Never operate the machine with guards damaged, missing or incorrectly assembled (grass catcher, side discharge guards, rear discharge guards).
- Don't use the machine if the attachments/tools are not installed in their seats.

- Never disengage, deactivate, remove or tamper with the safety systems/micro switches installed.
- Do not change the engine adjustments, or exceed the maximum rpm. If the engine is forced to run at an excessive speed, the risk of personal injury increases.
- Do not strain the machine too much and do not use a small machine for heavy-duty work; if you use the right machine, you will reduce the risk of hazards and improve the quality of your work.

## 2.4 MAINTENANCE, STORAGE AND TRANSPORT

Ensure regular maintenance and correct storage to maintain machine safety and high performance levels.

### Maintenance

- Never use the machine with worn or damaged parts. Faulty or worn-out parts must always be replaced and never repaired.
- To reduce the risk of fire, check for oil and/or fuel leaks on a regular basis.
- Be careful during adjustment of the machine to prevent entrapment of the fingers between moving parts of the cutting means and fixed parts of the machine.

**⚠ The noise and vibration levels shown in these instructions are the maximum levels for use of the machine. The use of an unbalanced cutting element, the excessive speed of movement, or the absence of maintenance have a significant influence on noise emissions and vibrations. Consequently, it is necessary to take preventive steps to eliminate possible damage due to high levels of noise and stress from vibration; Maintain the machine well, wear ear protection devices, and take breaks while working.**

### Storage

- Do not store the machine with fuel in the tank in an area where fuel vapours could reach a naked light, a spark or a strong heat source.
- To reduce fire risks, do not leave containers with debris inside a room.

## 2.5 ENVIRONMENTAL PROTECTION

Safeguarding the environment must be a relevant and priority aspect of machine use, of benefit to the community and the environment we live in.

- Avoid being a disturbance to the neighbourhood. Use this machine at reasonable times of the day only (not early morning or late evening when the noise could cause disturbance).
- Comply with local regulations for the disposal of packaging, deteriorated parts or any elements with a strong environmental impact; this waste must not be disposed of with regular waste, but must be separated and taken to collection centres, who will recycle the materials.
- Comply with local regulations for the disposal of waste materials.
- When the machine is withdrawn from service, do not dispose of it in the environment, but take it to a waste disposal facility in accordance with the local regulations in force.

## 3. GETTING TO KNOW THE MACHINE

### 3.1 DESCRIPTION OF THE MACHINE AND PLANNED USE

**This machine is pedestrian-controlled lawnmower.**

The machine is essentially composed of a motor which drives a cutting means enclosed in a casing, equipped with wheels and a handle.

The operator is able to operate the machine and use the main controls, always staying behind the handle at a safe distance from the rotating cutting means.

If the operator leaves the machine, the motor and cutting means will stop within a few seconds.

#### Intended use

This machine is designed and built to cut (and collect) grass in gardens and grassy areas, with a height according to its cutting capacity, driven by an operator walking behind it.

Generally speaking this machine can:

1. Mow the grass and collect it in the grass catcher bag.
2. Mow the grass and discharge it on the ground through the rear part (if available).
3. Mow the grass and discharge it on the ground laterally (if available).
4. Mow the grass, chop it and discharge it on the ground (mulching effect - if available).

The use of special attachments provided for by the Manufacturer as original equipment or which may be purchased separately, allows this work to be done in various operating modes, illustrated in this manual or the instructions that accompany the single attachments.

#### 3.1.1 Improper use

Any other usage, different than the afore-mentioned may be hazardous and harm persons and/or damage things.

Examples of improper use may include, but are not limited to:

- Allowing children, animals or other passengers on the machine as they could fall off and injure themselves or compromise safe driving by the operator;
- Letting oneself be transported by the machine;
- Using the machine to tow or push loads;
- Using the cutting means on surfaces other than grass;
- Using the machine for leaf or debris collection;
- Using the machine to trim hedges, or for cutting vegetation other than grass;
- using of the machine by more than one person.

**IMPORTANT** *Improper use of the machine will invalidate the warranty, relieve the Manufacturer from all liabilities, and the user will consequently be liable for all and any damage or injury to himself or others.*

#### 3.1.2 User types

This machine is intended for use by consumers, i.e. non-professional operators.

It is intended for "DIY" use only.

**IMPORTANT** *The machine must be used by one operator.*

### 3.2 SAFETY SIGNS

The machine has various symbols on it (Fig.2.0). Their function is to remind the operator of the correct conduct for use, with due care and caution. Meanings of the symbols:



**Warning.** Read the instructions before operating the machine



**Warning!** Do not put hands or feet inside the compartment of the cutting means. Remove the spark plug cap and read the instructions before carrying out any maintenance or repair work.



**Danger!** Risk of thrown objects. Keep all persons away from the work area whilst working.



**Danger! Danger of cutting.** Cutting means in motion. Do not put hands or inside the housing of the cutting means.

**IMPORTANT** *Any damaged or illegible decals must be replaced. Order replacement decals from an Authorised Service Centre.*

### 3.3 IDENTIFICATION LABEL

The identification label holds the following data (Fig.1.0).

1. Sound power level.
2. CE conformity marking.
3. Year of manufacture.
4. Type of machine.
5. Serial number.
6. Name and address of Manufacturer.
7. Article code.
8. Nominal power and maximum operating engine speed.
9. Weight in kg.

Write the identification data of the machine in the specific space on the label on the back of the cover page.

**IMPORTANT** *Quote the information on the product identification label whenever you contact an Authorised Service Centre.*

**IMPORTANT** *The example of the Declaration of Conformity is provided on the last pages of the manual.*

### 3.4 MAIN COMPONENTS (Fig.1)

- A. Chassis.
- B. Engine.
- C. Cutting means.
- D. Rear discharge guard.
- E. Side discharge guard (if equipped).
- F. Side discharge chute (if equipped).
- G. Grass catcher.
- H. Handle.
- I. Engine brake lever / cutting means.
- J. Drive engagement lever.

**⚠** *Strictly observe the indications and the safety regulations described in chap. 2..*

## 4. ASSEMBLY

Certain components of the machine are not installed in the factory and have to be assembled after unpacking, following the instructions below.

**⚠** *Unpacking and completing the assembly should be done on a flat and stable surface, with enough space for moving the machine and its packaging. Do not use the machine until all the instructions provided in the "ASSEMBLY" section have been carried out.*

### 4.1 UNPACKING (Fig.3.0)

1. Remove all the unassembled parts from the box.
2. Take out the machine and dispose of the box and packaging in compliance with local regulations.

### 4.2 HANDLE ASSEMBLY (Fig.4.A/B/C)

### 4.3 GRASS CATCHER ASSEMBLY (Fig.5,6,7)

### 4.4 CONNECTING THE BATTERY

- **Models with push-button electric start:** refer to the owner's manual of the engine.

## 5. CONTROLS

### 5.1 MANUAL START HANDGRIP (Fig.8.A)

### 5.2 PUSH-BUTTON ELECTRIC START COMMAND (Fig.8.B)

### 5.3 ENGINE BRAKE LEVER / CUTTING MEANS (Fig.9.A)

### 5.4 DRIVE ON LEVER (Fig.9.B)

**IMPORTANT** *The engine must be started only with the drive OFF.*

**IMPORTANT** *Avoid moving the machine backwards when the drive is ON.*

### 5.5 CUTTING HEIGHT ADJUSTMENT

**⚠ Do this when the cutting means is stationary.**

• **Adjustment** (See Fig.10.A)

## 6. USING THE MACHINE

**IMPORTANT** *For instructions on the engine and the battery (if equipped), refer to the corresponding manuals.*

### 6.1 PRELIMINARY PROCEDURES

Place the machine in a stable horizontal position on the ground.

#### 6.1.1 Filling with oil and fuel

**IMPORTANT** *The machine is supplied without engine oil and without fuel.*

Before using the machine for the first time after purchase, fill with fuel and top up the oil tank following the instructions and precautions provided in the engine instruction manual and in par. 7.2.1/7.2.2.

#### Before each use

Check the fuel and oil levels following the instructions provided in the engine manual and par. 7.2.1/7.2.2.

#### 6.1.2 Preparing the machine before starting work

**NOTE** *This machine can be used to mow lawns in various ways;*

#### a. Preparation for grass cutting and collection in the grass catcher:

1. For side discharge models: make sure that the guard (Fig. 11.A) is lowered and locked by the safety lever (Fig. 11.B).
2. Insert the grass catcher (Fig.11.C).

#### b. Preparation for grass cutting and rear grass discharge on the ground:

1. Lift the rear discharge guard (Fig.12.A) and fit the pin (Fig.12.B).
2. For models with side discharge: make sure that the guard (Fig. 12.C) is lowered and locked by the safety lever (Fig. 12.D).

To remove the pin: see Fig.12.A/B.

#### c. Preparation for grass mowing and chopping (mulching function):

Lift the rear discharge guard (Fig.13.A) and insert the chute plug (Fig.13.B) in the discharge opening. For models with side discharge: make sure that the side discharge guard (Fig. 13.C/D) is lowered and locked by the safety lever (Fig. 13.D).

To remove the chute plug: see Fig.13.E.

#### d. Preparation for grass cutting and side discharge on the ground:

1. Lift the rear discharge guard (Fig.14.A) and insert the chute plug (Fig.14.B) in the discharge opening.
2. Slightly push the safety lever (Fig.14.C) and lift the side discharge guard (Fig.14.D).
3. Insert the side discharge chute (Fig.14.E).
4. Close the side discharge guard (Fig.14.D) so as to lock the side discharge chute (Fig.14.E).

To remove the side discharge chute:

5. Slightly push the safety lever (Fig.14.C) and lift the side discharge guard (Fig.14.D).
6. Release the side discharge chute (Fig.14.E).

#### 6.1.3 Handle inclination adjustment (Fig.15/16)

**⚠ Do this when the cutting means is stationary.**

### 6.2 SAFETY CHECKS

**⚠ Always carry out the safety checks before use.**

#### 6.2.1 Safety check before every use

- Check the integrity and the correct mounting of all components of the machine;
- make sure that all fastening devices are correctly tightened;
- keep all surfaces of the machine clean and dry.

#### 6.2.2 Machine operating test

| Action   | Result   |
|--|--|
| 1. Start the machine (par. 6.3).                   | 1. The cutting means should move.  |
| 2. Release the engine brake lever / cutting means. | 2. The levers should return automatically and rapidly to the neutral position, the motor must switch off and the cutting means must stop within a few seconds. |

|  |   |
|--|---|
| <ol style="list-style-type: none"> <li>1. Start the machine (par. 6.3).</li> <li>2. Operate the drive lever.</li> <li>3. Disengage the drive lever.</li> </ol> | <ol style="list-style-type: none"> <li>2. The wheels should move the machine forward.</li> <li>3. The wheels should stop and the machine stops moving forward.</li> </ol> |
| Test driving   | No abnormal vibrations.<br>No abnormal sound.   |

**⚠** *If any of the results fail to match the indications provided in the tables, do not use the machine! Contact an Authorised Service Centre to have it checked and repaired if necessary.*

### 6.3 START-UP

**NOTE** *Start up the machine on a flat surface without obstacles or high grass.*

#### 6.3.1 Models with manual start handgrip (Fig.17.A/B)

**NOTE** *The engine brake lever / cutting means must be kept pulled to prevent the engine stop.*

#### 6.3.2 Models with push-button electric start command (Fig.18.A/B/C/D)

**NOTE** *The engine brake / cutting means lever must be kept pulled to prevent the engine stop.*

### 6.4 OPERATION

**IMPORTANT** *When working, always keep a safe distance from the cutting means, given by the length of the handle.*

#### 6.4.1 Grass cutting

1. Start moving forward and mowing the grass area.
2. Adjust the speed and cutting height (par. 5.5) in relation to lawn conditions (grass height, density and humidity) and the amount of grass to be cut.
3. It is recommended to always cut at the same height and in the two directions (Fig.20).

#### For mulching or rear grass discharge:

- Never cut more than one third of the total grass height per single pass (Fig.19).
- Keep the chassis clean (par. 7.4.2).

**For side discharge:** avoid discharging the cut grass from the side of the lawn yet to be mown.

#### 6.4.2 Grass catcher emptying

##### For grass catcher with contents indicator device:



Lifted = empty.



Lowered = full\*.

that the grass catcher is full and must be emptied.

To remove and empty the grass catcher:

1. Wait until the cutting means stops (Fig.21.A);
2. remove the grass catcher (Fig.21.B/C/D).

### 6.5 STOP (Fig.22.A)

**⚠** *After having stopped the machine, it will take a few seconds for the cutting means to stop.*

**⚠** *Do not touch the engine after stopping it. Risk of burns.*

**IMPORTANT** *Always stop the machine.*

- When moving between work areas.
- When driving on grass free surfaces.
- Close to an obstacle.
- Before adjusting the cutting height.
- Any time the grass catcher is removed or refitted.
- Any time the side discharge chute (if available) is removed or refitted.

### 6.6 AFTER USE (Fig.23.A/B/C/D)

1. Clean (par. 7.4).
2. If necessary, replace damaged components and tighten any slack screws and bolts.

**IMPORTANT** *Any time the machine is inactive or unattended:*

- Remove the spark plug cap (for models with manual start handgrip)(Fig.23.B/C).
- Press the tab and remove the permission key (for models with push-button electric start) (Fig.23.D).

## 7. MAINTENANCE

### 7.1 GENERAL INFORMATION

**⚠** *The safety regulations to follow are described in chap. 2. Strictly comply with these instructions to avoid serious risks or hazards:*

**⚠** *Before commencing any inspections, cleaning or maintenance/adjustments on the machine:*

- **Stop the machine.**
- **Make sure that any moving component has stopped.**
- **Wait until the engine cools down.**
- **Remove the spark plug cap (Fig. 23.B).**
- **Remove the key (Fig.23.D) (for models with push-button electric start).**
- **Read the relevant instructions.**
- **Use suitable clothing, protective gloves and goggles.**

### 7.2 ROUTINE MAINTENANCE

- The frequency and types of maintenance are summarised in the "Maintenance Table" (chapter 10).

**IMPORTANT** *Any maintenance and adjustment operations not described in this manual must be carried out by your Authorised Service Centre.*

#### 7.2.1 Refuelling

Place the machine in a stable horizontal position on the ground.

**⚠** *Refuelling must be performed with the machine stopped and with the spark plug cap removed.*

Refuel according to the methods and cautionary measures indicated in the owner's manual of the engine.



**⚠** *Machines with vertical storage possibility (chap. 8.1) have a tank that contains a fuel level indicator. Do not fill the tank above this level indicator (Fig.24.A).*

**IMPORTANT** *Clean any trace of leaked fuel. The warranty does not cover damages caused by the fuel to the plastic parts.*

**NOTE** *Fuel is perishable and should not remain in the tank for more than 30 days.*

### 7.2.2 Check/top-up engine oil

Check/top-up the engine oil according to the methods and cautionary measures indicated in the owner's manual of the engine.

For a correct operation of the machine, regularly replace the engine oil, according to the indications in the owner's manual of the engine.

Make sure to have restored the oil level before using the machine again.

## 7.3 OCCASIONAL MAINTENANCE

### 7.3.1 Cutting means

**⚠** *All operations concerning cutting means (disassembly, sharpening, balancing, repair, reassembly and / or replacement) must be performed at an Authorised Service Centre.*

**⚠** *Make sure damaged, misshapen or worn cutting means are replaced, together with the securing screws to preserve balance.*

**IMPORTANT** *Always use original cutting means bearing the code indicated in the "Technical Data" table.*

## 7.4 CLEANING

Clean thoroughly following the instructions below every time it is used.

### 7.4.1 Cleaning the machine

- Always make sure the air intakes are free of debris.
- Do not use aggressive liquids to clean the chassis.
- To reduce the risk of fire, keep the engine free of grass, leaves residues or excessive grease.
- Wash the machine with water after each cutting work.

### 7.4.2 Cleaning the cutting means assembly

- Remove grass debris and mud accumulated inside the chassis.

#### Models without washing connection

- To access the lower part, tilt the machine from the side indicated in the engine's manual, following the relative instructions, making sure that the machine is stable before carrying out any intervention.

- **For side discharge:** remove the discharge chute (if mounted - par. 6.1.2d.).

To wash the internal part of the cutting means assembly, proceed as follows (Fig.25.A/B/C):

1. always stay behind the handle of the lawn mower;
2. start the engine.

If the painting of the internal side of the chassis comes off, take immediate action, by retouching the painting with anti-rust paint.

### 7.4.3 Cleaning the grass catcher (Fig.26.A/B)

Clean the grass catcher and leave it to dry.

## 7.5 BATTERY

- The battery is supplied for the models with push-button electric start. For instructions regarding the battery life, recharging, storage and maintenance, follow the instructions in the instructions manual of the engine.

## 8. STORAGE

When the machine is to be stored away:

1. Start the engine outdoors and leave it running at idle until it stops in order to consume all the fuel left in the carburettor;
2. clean the machine thoroughly (par. 7.4);
3. check the integrity of the machine;
4. store the machine:
  - in a dry place;
  - protected from inclement weather;
  - in a place out of children's reach;
  - making sure that keys or tools used for maintenance are removed.

## 8.1 VERTICAL STORAGE

- If necessary, some models (see the Technical Data Table) can be stored vertically (Fig.27).

**⚠** *Do not store the machine upright with the tank filled above the lowest mark of the fuel level indicator (Fig.24.A).*

- Proceed as follows:

1. Remove the spark plug cap (Fig.23.B) or remove the key (Fig.23.D) or the battery (for models with push-button electric start command).
2. Move the cutting height to the second lower position (see chapter 5.5);
3. Carefully fold the handle in closed position and tighten the levers (Fig.27);
4. Put the machine in vertical position and carefully fold the handle in closed position and tighten the levers (Fig.27);

**⚠** *Store the machine so as to avoid risk in the event of accidental contact with people, children or animals.*

**⚠** *Do not attempt to store in vertical position machines that have not been designed for this purpose.*

## 9. HANDLING AND TRANSPORTATION

Whenever the machine is to be handled, raised, transported or tilted you must:

- Stop the machine (par.6.5) until the moving parts come to a complete halt.
- Remove the spark plug cap (Fig.23.B) or remove the key (Fig.23.D) or the battery (for models with push-button electric start command).
- Wear heavy work gloves.
- Hold the machine in the points offering a safe grip, taking into account the weight and its division.
- Use an appropriate number of people for the weight of the machine and the characteristics of the vehicle or the place where it must be placed or collected.
- Make sure that machine movements do not cause damage or injuries.

When transporting the machine on a vehicle or trailer, always:

- Use an access ramp of suitable strength, width and length.
- Load the machine with the motor switched off and pushed by an adequate number of people.
- Lower the cutting means assembly (par 5.5).
- Position it so that it cannot cause a hazard for anybody.
- Fasten firmly to the device of transport using ropes or chains to prevent it from tipping over causing damage and fuel leaks.

.....  
 ⚠ **Do not transport machines that can be stored in vertically in such an upright position.**  
 .....

## 10. MAINTENANCE TABLE

| Intervention   | Frequency      | Notes                          |
|--|----------------|--------------------------------|
| <b>MACHINE</b>   |                |                                |
| Check all fasteners ; Safety checks/check controls; Check the rear/lateral discharge guards; Check the grass catcher bag and lateral discharge chute; Check the cutting means. | Before use     | par. 6.2.2                     |
| General cleaning and inspection; Checking for any damage to the machine. If necessary, contact the authorised service centre.  | After each use | par. 7.4                       |
| Replacing the cutting means  | -              | par. 7.3.1 ***                 |
| <b>ENGINE</b>  |                |                                |
| Checking/topping up fuel level; Check/top-up engine oil  | Before use     | par. 6.1.1 / 7.2.1 * / 7.2.2 * |
| Air filter check and cleaning; Spark plug contacts check and cleaning; Spark plug replacement; Charging the battery  | *              | * / par. 7.5 *                 |

\* Refer to the engine manual. \*\*\* Operation to be performed at the first signs of any malfunction

\*\*\* The operation must be carried out by your Dealer or a Authorised Service Centre

## 11. PROBLEM IDENTIFICATION

If problems persist after having performed the above operations, contact your dealer.

| PROBLEM   | PROBABLE CAUSE  | SOLUTION  |
|---|---|---|
| 1. The engine does not start, does not keep running, operates irregularly or stops during operation | Incorrect starting procedure  | Follow the instructions (see chap. 6.3).  |
|   | No oil or fuel in the engine.   | Check the oil and fuel levels (see chap. 7.2.1 / 7.2.2).  |
|   | Dirty spark plug or incorrect electrode gap.  | Check the spark plug (refer to the engine manual).  |
|   | Clogged air filter.   | Clean and / or replace the filter (Refer to the engine manual).   |
|   | Carburation fault.  | Contact your Authorised Service Centre  |
| 2. Engine flooding.   | The manual start handgrip has been operated repeatedly with the starter engaged.        | Refer to the engine manual.   |
|   | The manual start handgrip has been operated repeatedly with the spark plug cap removed. | Insert the spark plug cap and try to start the engine. (Refer to the engine manual).  |
| 3. The cut grass is no longer collected in the grass catcher.                                       | The cutting means hit a foreign object.   | Stop the engine and remove the spark plug cap. Check for any damage and contact an authorised service centre (section 7.3.1).   |
|   | The inner part of the chassis is soiled.  | Clean the internal part of the chassis (par. 7.4.2).  |
| 4. Mowing is difficult.   | The cutting means is not in good condition  | Contact the Authorised Service Centre for the sharpening or replacement of the cutting means.   |
| 5. Excessive noise and/ or vibration is experienced whilst working.                                 | Damaged or loose parts<br>The pin on the cutting means is out of its seat.              | Stop the machine and disconnect the spark plug cable (Fig. 23.B). Check for any damage or loose parts. All checks, replacements or repairs should be carried out by your authorised service centre. |
|   | Cutting means fittings are loose or the cutting means is damaged.                       | Stop the engine and remove the spark plug cap (Fig.23.B). Contact an authorised service centre (section 7.3.1).   |

## 12. ATTACHMENTS ON REQUEST

### 12.1 MULCHING KIT (Fig.28)

Finely chops the cut grass and leaves it on the lawn.

**DICHIARAZIONE CE DI CONFORMITÀ** (Istruzioni Originali)  
(Direttiva Macchine 2006/42/CE, Allegato II, parte A)

1. **La Società:** STIGA S.p.A. – Via del Lavoro, 6 – 31033 Castelfranco Veneto (TV) – Italy
2. Dichiaro sotto la propria responsabilità, che la macchina: Tosaerba con conducente a piedi / taglio erba

- a) Tipo / Modello Base  
b) Mese/Anno di costruzione  
c) Matricola

CP1 434

- d) Motore a scoppio

3. É conforme alle specifiche delle direttive:

- MD: 2006/42/EC  
e) Ente Certificatore: /  
f) Esame CE del tipo: /

- OND: 2000/14/EC, ANNEX VI - 2005/88/EC  
D. Lgs. 262/2002, ANNEX VI, proc. 1 (Italy)  
e) Ente Certificatore:

N°0197 – TÜV Rheinland LGA Products GmbH  
Tillystrasse 2, 90431 Nürnberg – Germany

- EMCD: 2014/30/EU  
• RoHS II: 2011/65/EU - 2015/863/EU

4. Riferimento alle Norme armonizzate:

EN ISO 5395-1:2013+A1:2018  
EN ISO 5395-2:2013+A1:2016+A2:2017  
EN 50581:2012

EN 55012:2007+A1:2009  
EN ISO 14982:2009

- g) Livello di potenza sonora misurato 94 dB(A)  
h) Livello di potenza sonora garantito 95 dB(A)  
i) Ampiezza di taglio 41 cm

- n) Persona autorizzata a costituire il Fascicolo Tecnico:

STIGA S.p.A.  
Via del Lavoro, 6  
31033 Castelfranco Veneto (TV) - Italia

- o) Castelfranco V.to, 13.03.2019

Sr. VP Product Technical Division  
Maurizio Tursini



**DICHIARAZIONE CE DI CONFORMITÀ (calcolatori Original)**  
(Direttiva Macchine 2006/42/CE, Allegato II, parte A)

1. La Società: **STBA S.p.A. - Via del Lavoro, 6 - 31033 Castelnuovo Veneto (TV) - Italy**
2. Dichiaro nella mia piena responsabilità, che la macchina: **Torceda con compressore a pistoni / foglio carta**

- a) Tipo / Modello Base:  
b) Descrizione di costruzione:  
c) Modificata

CP1 484

- d) Marca: **a scoppio**

3. È conforme alle specifiche delle direttive:

- MD: 2006/42/CE  
e) Ente Certificatore: /  
f) Esame CE del tipo: /
- CMC: 2000/14/CE, ANNEK VI - 2005/88/CE  
D.Lgs. 252/2002, ANNEK VI, par. 1 (Italy)  
e) Ente Certificatore:

NTD157 - TÜV Rheinland LGA Products GmbH  
Tilgmannstr. 2, 90431 Nürnberg - Germany

- EMC: 2014/53/EU
- RoHS: lt: 2011/65/EU - 2015/863/EU

4. Riferimenti alle Norme armonizzate:

EN ISO 5295-1:2013+A1:2016  
EN ISO 5295-2:2013+A1:2016+A2:2017  
EN 50521:2012

EN 55012:2007+A1:2009  
EN ISO 14982:2009

- a) Livello di potenza sonora misurato  
b) Livello di potenza sonora garantito  
c) Assorbimento di suono

95 dB(A)  
95 dB(A)  
45 cm

- d) Persona autorizzata a compilare il Fascicolo Tecnico:

**STBA S.p.A.**  
Via del Lavoro, 6  
31033 Castelnuovo Veneto (TV) - Italia

- e) Certificato V.3a, 13.08.2019

©: WP Product Technical Division  
Membro Tecnici





**IT** • Il contenuto e le immagini del presente manuale d'uso sono stati realizzati per conto di STIGA S.p.A. e sono tutelati da diritto d'autore – E' vietata ogni riproduzione o alterazione anche parziale non autorizzata del documento.

**BG** • Съдържанието и изображенията в настоящото ръководство са извършени за STIGA S.p.A. и са защитени с авторски права – Забранява се всяко неотризирано възпроизвеждане или промяна, дори и отчасти на документа.

**BS** • Sadržaj i slike iz ovog korisničkog priručnika napravljeni su isključivo za STIGA S.p.A. i zaštićeni su autorskim pravima – zabranjena je svaka neovlaštena reprodukcija ili izmjena dokumenta, djelomično ili u potpunosti.

**CS** • Obsah a obrázky v tomto návodu k použití byly zpracovány jménem společnosti STIGA S.p.A. a jsou chráněny autorským právem – Reprodukce či nepovolené pozměňování tohoto dokumentu, a to i částečně, je zakázáno.

**DA** • Indhold og illustrationer i denne vejledning er blevet skabt på vegne af STIGA S.p.A. og er beskyttet af ophavsret – Enhver gengivelse eller ændring, også delvis, af dokumentet uden autorisation hertil er forbudt.

**DE** • Inhalt und Bilder dieser Bedienungsanleitung wurden im Namen von STIGA S.p.A. erstellt und sind urheberrechtlich geschützt – Jede nicht genehmigte Vervielfältigung oder Veränderung, auch auszugsweise, dieses Dokuments ist verboten.

**EL** • Το περιεχόμενο και οι εικόνες στο παρόν εγχειρίδιο χρήσης δημιουργήθηκαν για λογαριασμό της εταιρείας STIGA S.p.A. και προστατεύονται από πνευματικά δικαιώματα – Απαγορεύεται οποιαδήποτε αναπαραγωγή ή τροποποίηση, έστω και μερική, του εγγύρφου χωρίς έγκριση.

**EN** • The content and images in this User Manual were produced expressly for STIGA S.p.A. and are protected by copyright – any unauthorised reproduction or modification to the document, either partially or in full, is prohibited.

**ES** • El contenido y las imágenes del presente manual de uso han sido creados por STIGA S.p.A. y están protegidos por los derechos de autor – Se prohíbe toda reproducción o modificación, incluso parcial, no autorizada del documento.

**ET** • Käesoleva kasutusjuhendi sisu ja kujutised on toodetud konkreetselt ettevõttele STIGA S.p.A. ja neile rakendub autorikaitseseadus – dokumendi igasugune osaline või täielik ilma loata reprodutseerimine või muutmine on keelatud.

**FI** • Tämän käyttöoppaan sisältö ja kuvat on valmistettu STIGA S.p.A. -yhtiön toimesta ja niitä suojaa tekijänoikeuslaki. – Asiakirjan kaikenlainen kopiointi tai muuttaminen, osittainkin, on kielletty ilman erityistä lupaa.

**FR** • Le contenu et les images du présent manuel d'utilisation ont été réalisés pour le compte de STIGA S.p.A. et sont protégés par un droit d'auteur – Toute reproduction ou modification non autorisée, même partielle, du document, est interdite.

**HR** • Sadržaj i slike u ovom priručniku za uporabu izrađeni su za tvrtku STIGA S.p.A. te su obuhvaćeni autorskim pravima – Zabranjuje se neovlašteno umnožavanje ili prilagodba, djelomična ili u cijelosti, ovog dokumenta.

**HU** • Ennek a használati útmutatónak a tartalma és a benne szereplő képek kizárólag a STIGA S.p.A. számára készültek és szerzői joggal védettek – tilos a dokumentum bármely részének vagy egészének engedély nélküli sokszorosítása és módosítása.

**LT** • Šio naudotojo vadovo turinys ir paveikslėliai skirti tik „STIGA S.p.A.“ ir yra saugomi autorių teisėmis – dokumentą atgaminti ar modifikuoti, visiškai arba iš dalies, yra draudžiama.

**LV** • Šis lietotāja rokasgrāmatas saturs un attēli ir veidoti tikai STIGA S.p.A. un ir aizsargāti ar autoritētibām. Jebkāda dokumenta vai tā daļas prettiesiska kopēšana vai pārveide ir stingri aizliegta.

**MK** • Содржината и сликите во Упатството за корисникот се подготвени исклучиво за STIGA S.p.A. и се заштитени со авторски права – забрането е секое делумно или целосно неовластено репродуцирање или измена на документот.

**NL** • De inhoud en de afbeeldingen van deze gebruikshandleiding werden gerealiseerd voor rekening van STIGA S.p.A. en zijn beschermd door het auteursrecht – Elke niet-geautoriseerde reproductie of wijziging, ook gedeeltelijke, van het document is verboden.

**NO** • Innholdet og bildene i denne brukerveiledningen er utført på oppdrag fra STIGA S.p.A. og er beskyttet ved opphavsrett – Enhver gjengivelse eller endring, selv kun delvis, er forbudt.

**PL** • Treść oraz ilustracje zawarte w niniejszej instrukcji obsługi powstały na zlecenie spółki STIGA S.p.A. i są chronione prawami autorskimi – Zabrania się wszelkiego kopiowania bądź modyfikowania, także częściowego, niniejszego dokumentu bez uzyskania stosownej zgody.

**PT** • As imagens e os conteúdos contidos no presente Manual do Utilizador foram expressamente criados para uso exclusivo da STIGA S.p.A., encontrando-se protegidos por direitos de autor. Qualquer tipo de reprodução ou alteração, parcial ou integral, não autorizadas deste Manual estão expressamente proibidas.

**RO** • Conținutul și imaginile din manualul de utilizare de față au fost realizate în numele STIGA S.p.A. și sunt protejate de drepturi de autor – Este interzisă orice reproducere sau modificare chiar și parțială neautorizată a documentului.

**RU** • Тесты и изображения, содержащиеся в настоящем руководстве, были созданы в интересах STIGA S.p.A. и защищены авторскими правами – Любое несанкционированное воспроизведение или изменение документа запрещено.

**SK** • Obsah a obrázky v tomto návode na používanie boli spracované menom spoločnosti STIGA S.p.A. a sú chránené autorským právom – Reprodukcie či nepovolené pozměňovanie tohto dokumentu, a to aj čiastočne, je zakázané.

**SL** • Vsebine in slike v tem uporabniškem priručniku so izdelane za podjetje STIGA S.p.A. in so zaščiten z avtorskimi pravicami – vsakršno nepoblaščenno razmnoževanje ali spreminjanje dokumenta, v celoti ali delno, je prepovedano.

**SR** • Sadržaj i slike ovog priručnika za upotrebu su napravljeni u ime STIGA S.p.A. i zaštićeni su autorskim pravima – Zabranjena je svaka potpuna ili delimična reprodukcija ili izmena dokumenta bez odobrenja.

**SV** • Innehållet och bilderna i denna användarhandbok har framställts för STIGA S.p.A. och skyddas av upphovsrätt – all form av reproduktion eller ändring, även partiell, som inte auktoriserats är förbjuden.

**TR** • Bu Kullanıcı Kilavuzundaki içerik ve resimler açıkça STIGA S.p.A. için üretilmiştir ve telif hakkı ile korunmaktadır – dokümanın izinsiz olarak tamamen ya da kısmen herhangi bir şekilde çoğaltılması ya da değiştirilmesi yasaktır.



|                                 |  |
|---------------------------------|--|
| .....<br>.....<br>.....         |  <b>LWA</b><br><br>.....<br><b>dB</b> |
| Type: .....                     |  |
| Art.N .....<br>..... -s/n ..... |  |
| <b>CE</b>                       |  |