

CP1 430 Li 48 series

CP1 430 Li D48 series

CP1 480 Li 48 series

CP1 480 Li D48 series

CP1 530 Li D48 series



**IT** Tosaerba a batteria con conducente a piedi  
MANUALE DI ISTRUZIONI

ATTENZIONE: prima di usare la macchina, leggere attentamente il presente libretto.

**BG** Акумулаторна носачка с изправен водач  
УПЪТВАНЕ ЗА УПОТРЕБА

ВНИМАНИЕ: преди да използвате машината прочетете внимателно настоящата книжка.

**BS** Kosilica na bateriju na guranje  
UPUTSTVO ZA UPOTREBU

PAŽNJA: prije nego što koristite ovu mašinu, pažljivo pročitajte priručnik s uputama.

**CS** Akumulátorová sekačka se stojící obsluhou  
NÁVOD K POUŽITÍ

UPOZORNĚNÍ: před použitím stroje si pozorně přečtěte tento návod k použití.

**DA** Batteridreven plæneklipper betjent af gående personer  
BRUGSANVISNING

ADVARSEL: læs instruktionsbogen omhyggeligt igennem, før du tager denne maskine i brug.

**DE** Handgeführter batteriebetriebener Rasenmäher  
GEBRAUCHSANWEISUNG

ACHTUNG: vor Inbetriebnahme des geräts die gebrauchsanleitung aufmerksam lesen.

**EL** Χλοοκοπτική μηχανή μπαταρίας με όρθιο χειριστή  
ΟΔΗΓΙΕΣ ΧΡΗΣΗΣ

ΠΡΟΣΟΧΗ: πριν χρησιμοποιήσετε το μηχάνημα, διαβάστε προσεκτικά το παρόν εγχειρίδιο.

**EN** Pedestrian-controlled walk-behind battery powered lawn mower  
OPERATOR'S MANUAL

WARNING: read thoroughly the instruction booklet before using the machine.

**ES** Cortadora de pasto por batería con operador de pie  
MANUAL DE INSTRUCCIONES

ATENCIÓN: antes de utilizar la máquina, leer atentamente el presente manual.

**ET** Seisva juhiga akutoitega muruniitja  
KASUTUSJUHEND

TÄHELEPANU: enne masina kasutamist lugeda tähelepanelikult antud kasutusjuhendit.

**FI** Kävellèn ohjattava akkukäyttöinen ruohonleikkuri  
KÄYTTÖOHJEET

VAROITUS: lue käyttöopas huolellisesti ennen koneen käyttöä

**FR** Tondeuse à gazon alimentée par batterie et à conducteur à pied  
MANUEL D'UTILISATION

ATTENTION: lire attentivement le manuel avant d'utiliser cette machine.

**HR** Baterijska ručno upravljana kosilica trave  
PRIRUČNIK ZA UPORABU

POZOR: prije uporabe stroja, pažljivo pročitajte ovaj priručnik.

**HU** Gyalogvezetésű akkumulátoros fűnyírógép  
HASZNÁLATI UTASÍTÁS

FIGYELEM! a gép használatá előtt olvassa el figyelmesen a jelen kézikönyvet.

**LT** Pėsčio operatoriaus valdoma akumuliatorinė vejapjovė  
NAUDOJIMO INSTRUKCIJOS

DĖMESIO: prieš naudojant įrenginį, atidžiai perskaityti šį naudotojo vadovą.

**LV** Ar bateriju darbināma no aizmugures ejot vadāma zāliena pļaujmašina  
LIETOŠANAS INSTRUKCIJA

UZMANĪBU: pirms aparāta lietošanai rūpīgi izlasiet doto instrukciju.

**MK** Тревокосачка на батерии со оператор на нозе  
УПАТСТВА ЗА УПОТРЕБА

ВНИМАНИЕ: прочитајте го внимателно ова упатство пред да ја користите машината.

**NL** Lopend bediende grasmaaier met batterij  
GEBRUIKERSHANDLEIDING

LET OP: vooraleer de machine te gebruiken, dient men deze handleiding aandachtig te lezen.

**NO** Håndført batteridrevet gressklipper  
INSTRUKSJONSBOK

ADVARSEL: les denne bruksanvisningen nøye før du bruker maskinen.

**PL** Kosiarka akumulatorowa prowadzona przez operatora pieszego  
INSTRUKCJE OBSŁUGI

OSTRZEŻENIE: przed użyciem maszyny, należy uważnie przeczytać niniejszą instrukcję.

**PT** Corta-relvas a bateria para operador apeado  
MANUAL DE INSTRUÇÕES

ATENÇÃO: antes de usar a máquina, leia atentamente o presente manual.

**RO** Mașină pe baterii de tuns iarba cu conducător pedestru  
MANUAL DE INSTRUCȚIUNI

ATENȚIE: înainte de a utiliza mașina, citiți cu atenție manualul de față.

**RU** Газонокосилка с пешеходным управлением с батарейным питанием  
РУКОВОДСТВО ПО ЭКСПЛУАТАЦИИ

ВНИМАНИЕ: прежде чем пользоваться оборудованием, внимательно прочтите это руководство по эксплуатации.

**SK** Akumulátorová kosačka so stojacou obsluhou  
NÁVOD NA POUŽITIE

UPOZORNENIE: pred použitím stroja si pozorne prečítajte tento návod.

**SL** Akumulatorska kosilnica za stoječega delavca  
PRIROČNIK ZA UPORABO

POZOR: preden uporabite stroj, pazljivo preberite priročnik z navodili.

**SR** Kosačica na bateriju na garanje  
PRIRUČNIK SA UPUTSTVIMA

PAŽNJA: pre korišćenja mašine pažljivo pročitati ovaj priručnik.

**SV** Batteridriven förarladd gräsklippare  
BRUKSANVISNING

WARNING: läs igenom hela detta häfte innan du använder maskinen.

**TR** Arkadan ayak kumandalı bataryalı çim biçme makinesi  
KULLANIM KILAVUZU

DIKKAT: makineyi kullanmadan önce talimatlar içeren kilavuzu dikkatle okuyun.

ITALIANO - Istruzioni Originali .....	<b>IT</b>
БЪЛГАРСКИ - Инструкция за експлоатация .....	<b>BG</b>
BOSANSKI - Prijevod originalnih uputa .....	<b>BS</b>
ČESKY - Překlad původního návodu k používání .....	<b>CS</b>
DANSK - Oversættelse af den originale brugsanvisning .....	<b>DA</b>
DEUTSCH - Übersetzung der Originalbetriebsanleitung .....	<b>DE</b>
ΕΛΛΗΝΙΚΑ - Μετάφραση των πρωτοτύπων οδηγιών .....	<b>EL</b>
ENGLISH - Translation of the original instruction .....	<b>EN</b>
ESPAÑOL - Traducción del Manual Original .....	<b>ES</b>
EESTI - Algupärase kasutusjuhendi tõlge .....	<b>ET</b>
SUOMI - Alkuperäisten ohjeiden käännös .....	<b>FI</b>
FRANÇAIS - Traduction de la notice originale .....	<b>FR</b>
HRVATSKI - Prijevod originalnih uputa .....	<b>HR</b>
MAGYAR - Eredeti használati utasítás fordítása .....	<b>HU</b>
LIETUVIŠKAI - Originalių instrukcijų vertimas .....	<b>LT</b>
LATVIEŠU - Instrukciju tulkojums no oriģināl valodas .....	<b>LV</b>
МАКЕДОНСКИ - Превод на оригиналните упатства .....	<b>MK</b>
NEDERLANDS - Vertaling van de oorspronkelijke gebruiksaanwijzing .....	<b>NL</b>
NORSK - Oversettelse av den originale bruksanvisningen .....	<b>NO</b>
POLSKI - Tłumaczenie instrukcji oryginalnej .....	<b>PL</b>
PORTUGUÊS - Tradução do manual original .....	<b>PT</b>
ROMÂN - Traducerea manualului fabricantului .....	<b>RO</b>
РУССКИЙ - Перевод оригинальных инструкций .....	<b>RU</b>
SLOVENSKY - Preklad pôvodného návodu na použitie .....	<b>SK</b>
SLOVENŠČINA - Prevod izvornih navodil .....	<b>SL</b>
SRPSKI - Prevod originalnih uputstva .....	<b>SR</b>
SVENSKA - Översättning av bruksanvisning i original .....	<b>SV</b>
TÜRKÇE - Orijinal Talimatların Tercümesi .....	<b>TR</b>

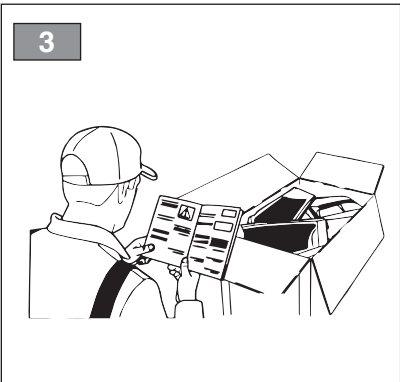
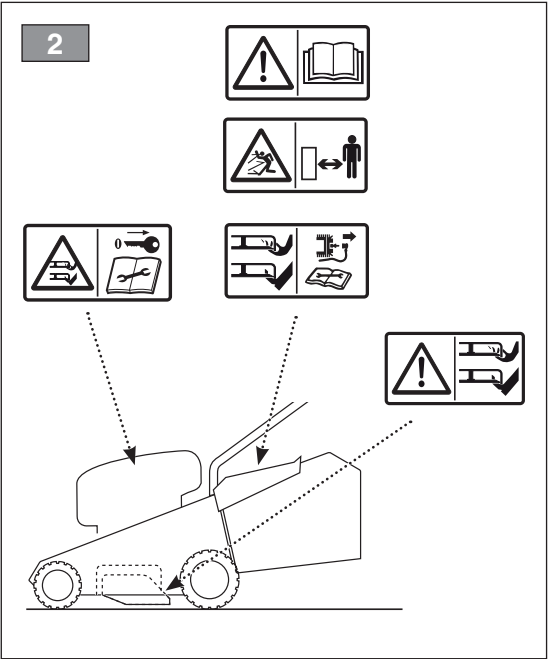
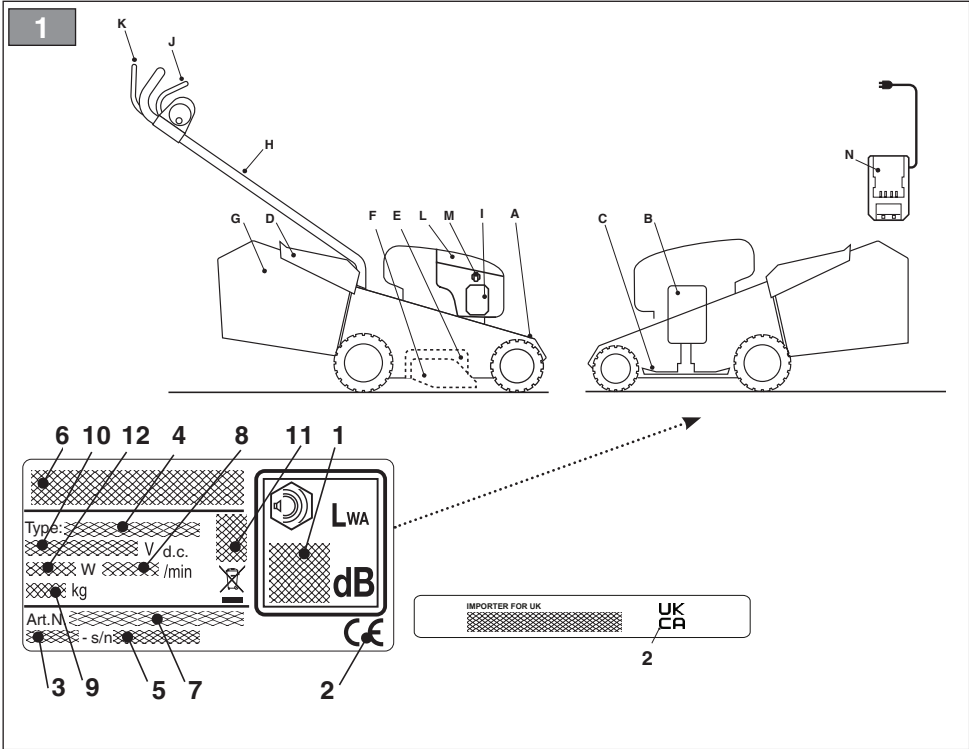



x2



x2



x2



x1

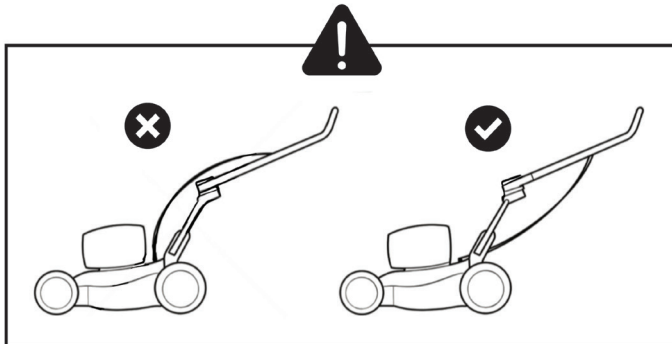
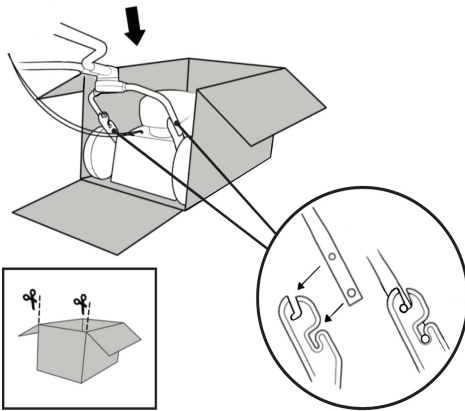
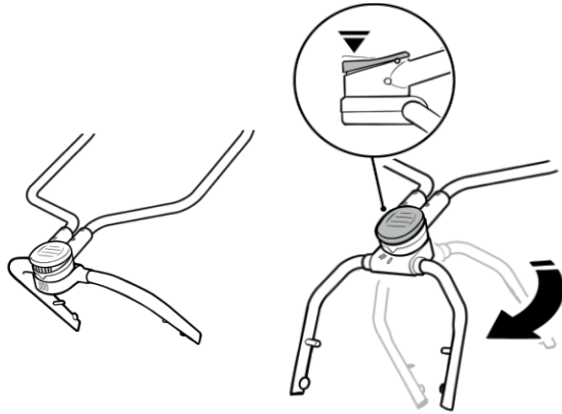

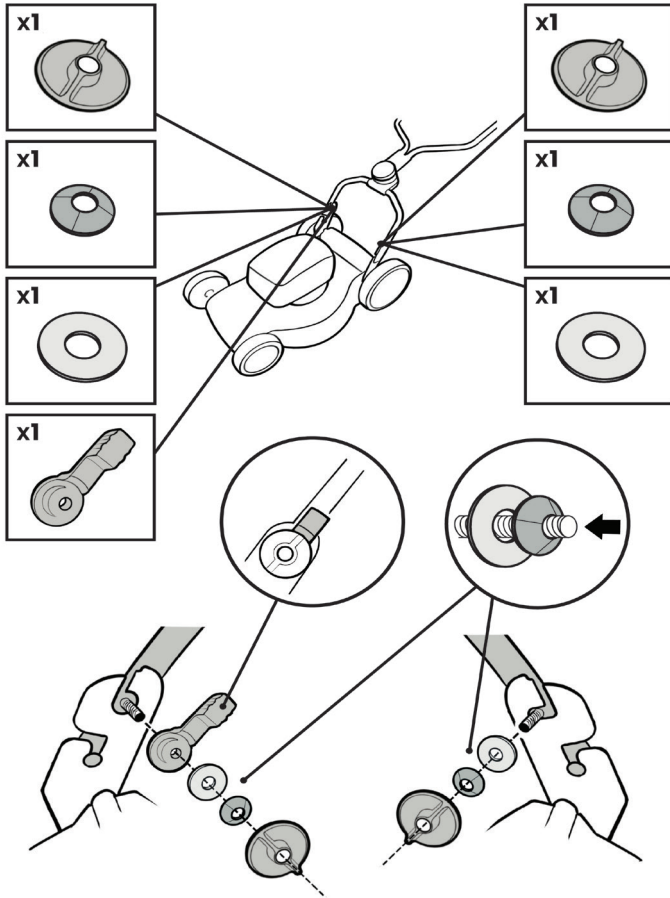

**A**

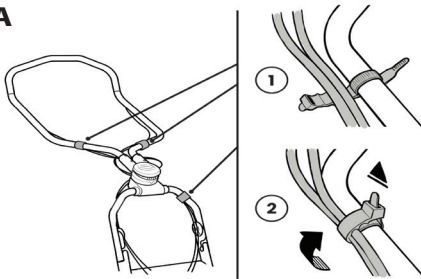

**B**

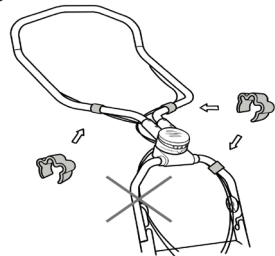

5

1

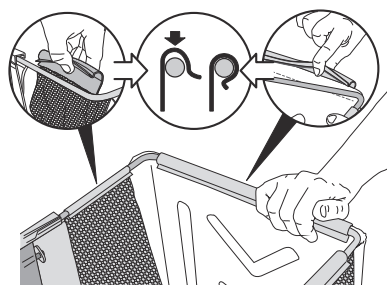

2



6

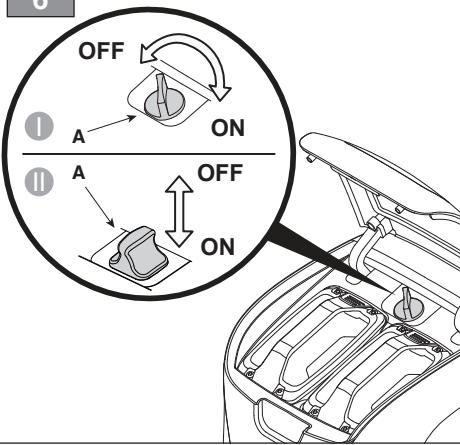

7

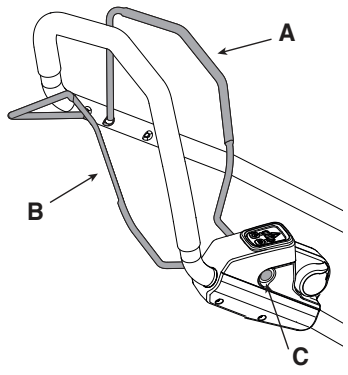

8

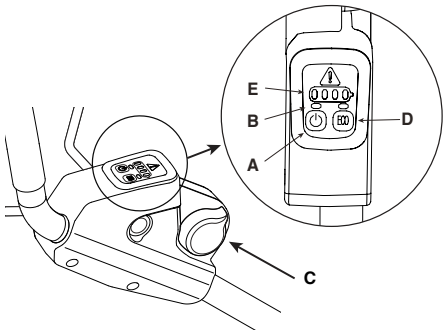

9

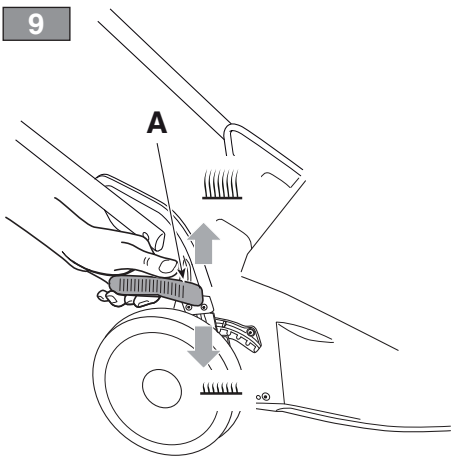

10

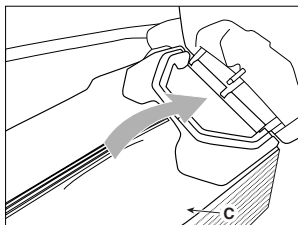
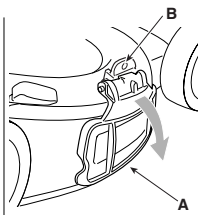

11

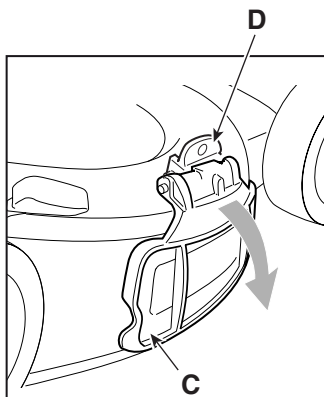
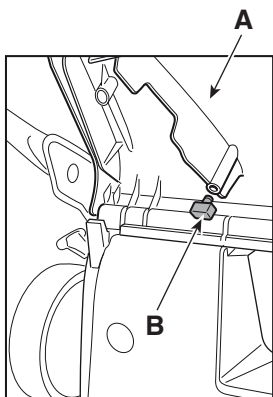
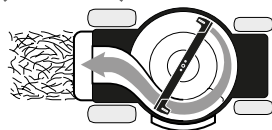
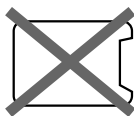

12

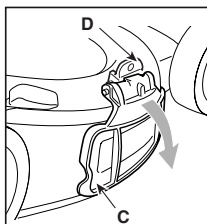
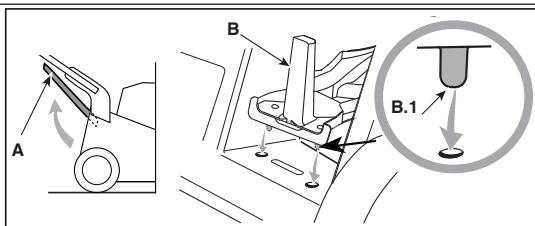



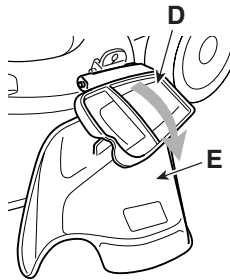
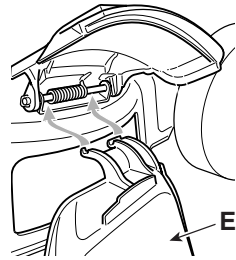
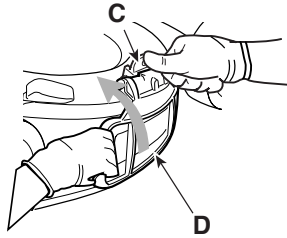
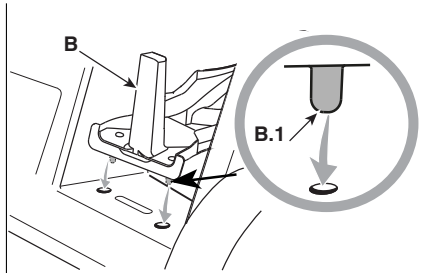
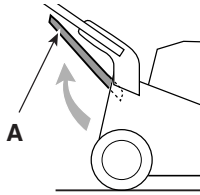

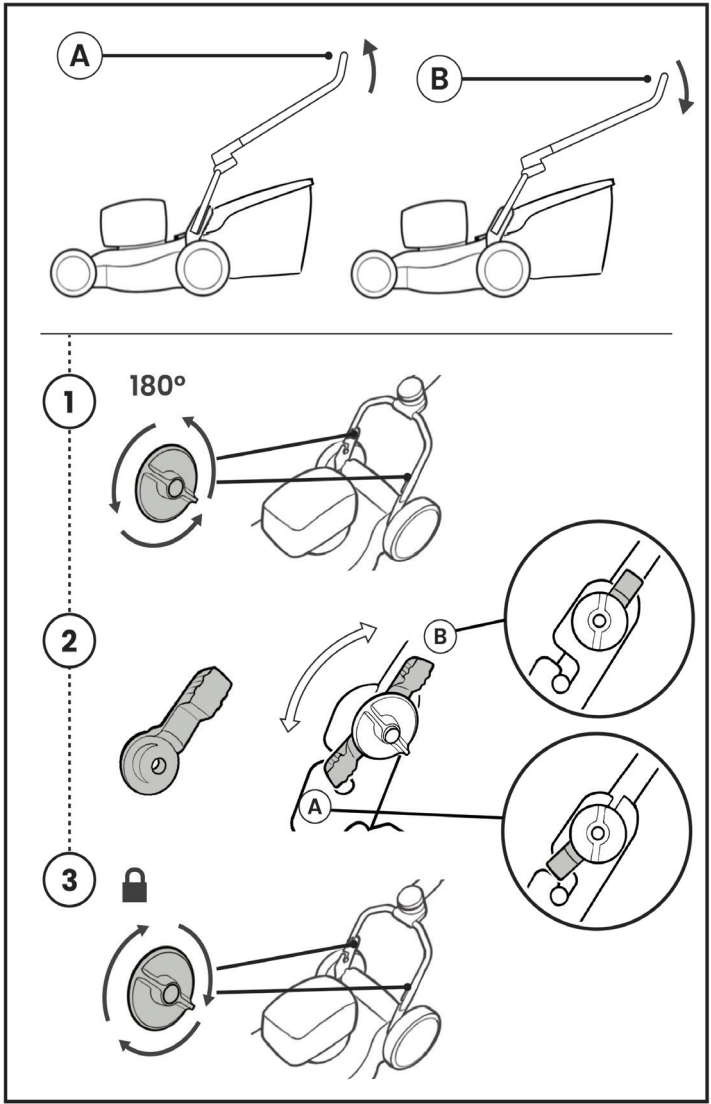

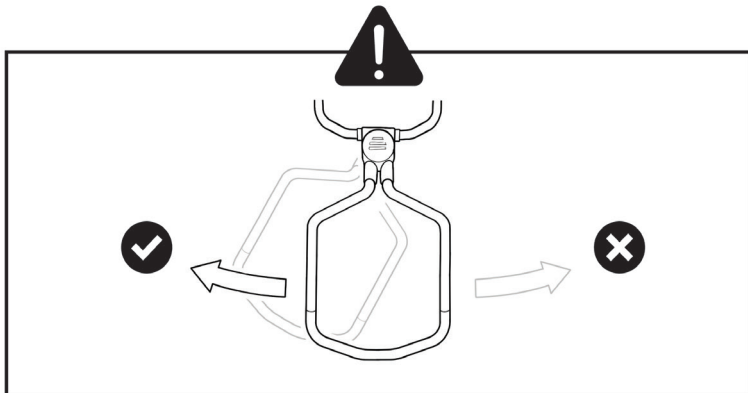
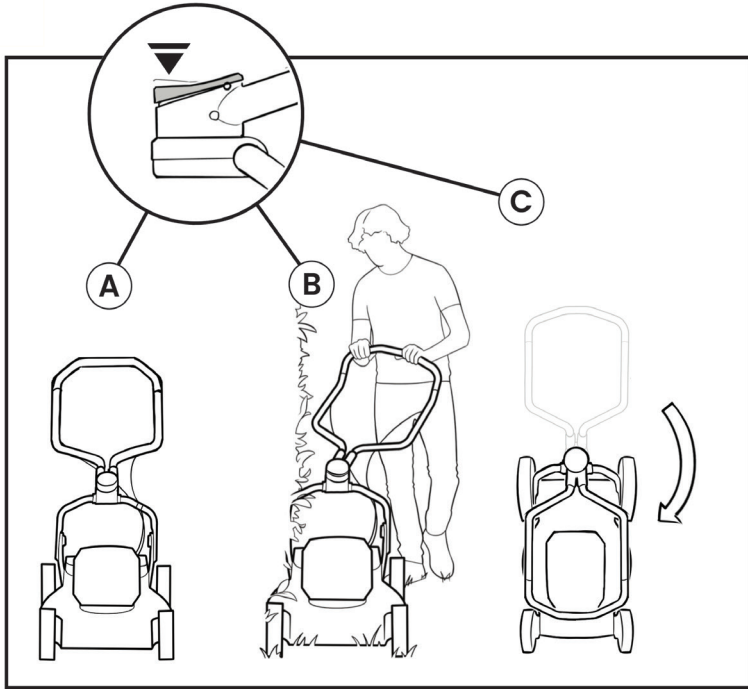

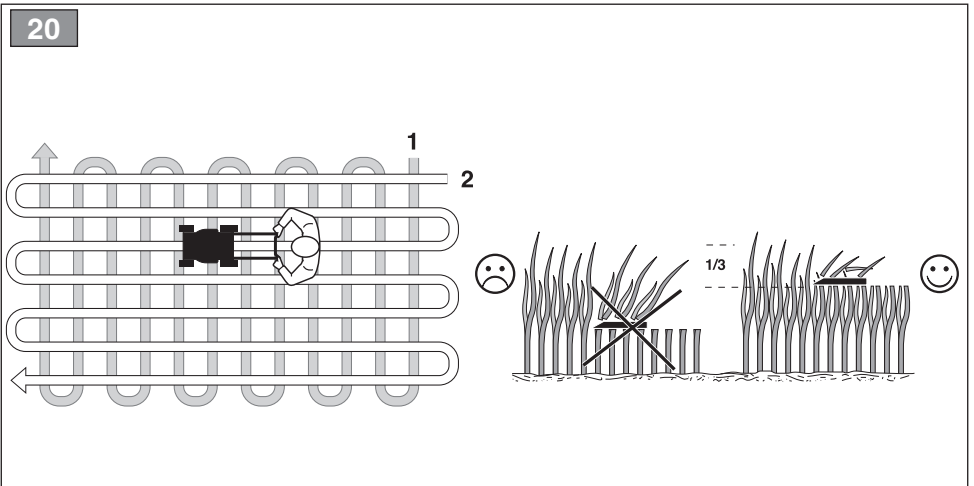
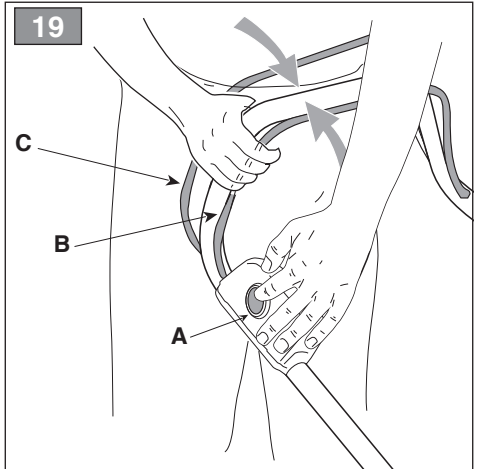
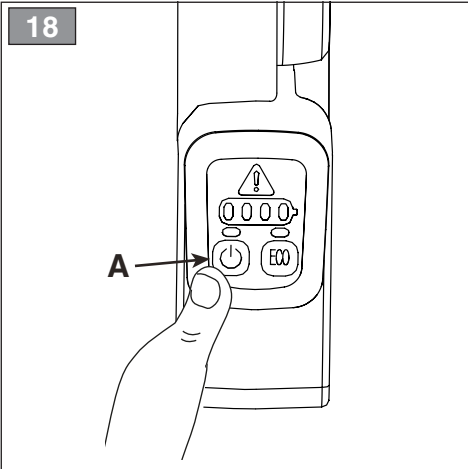
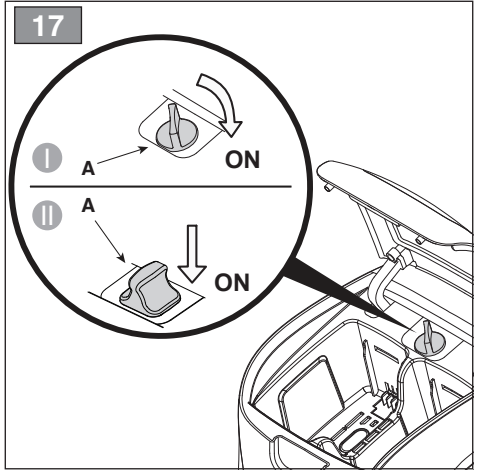
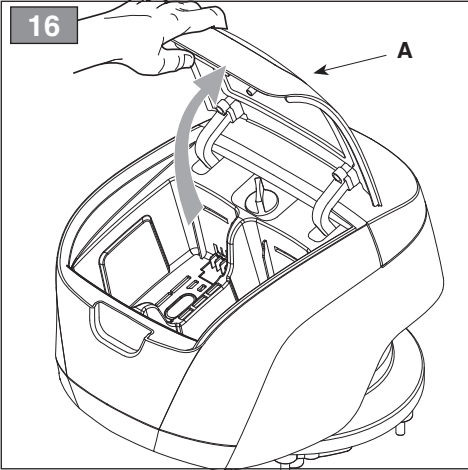

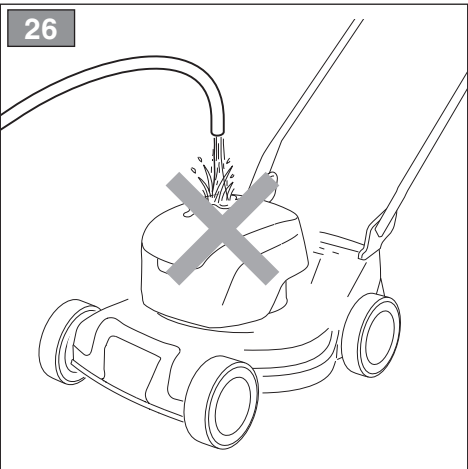
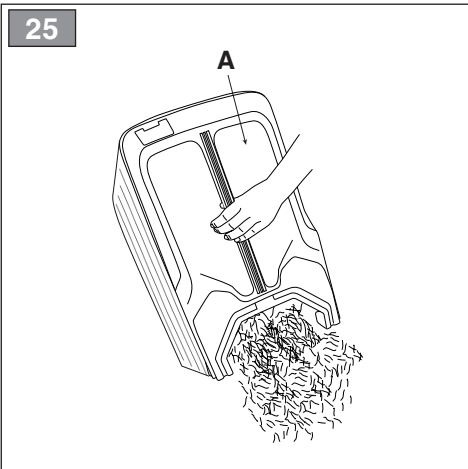
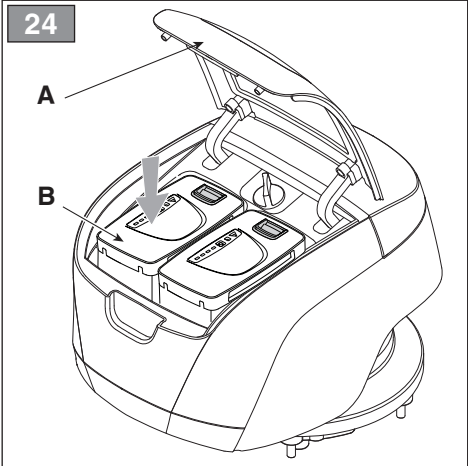
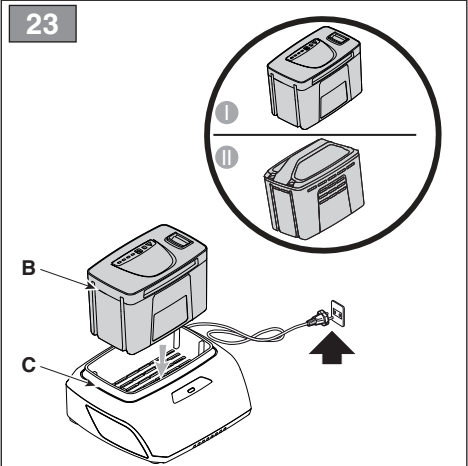
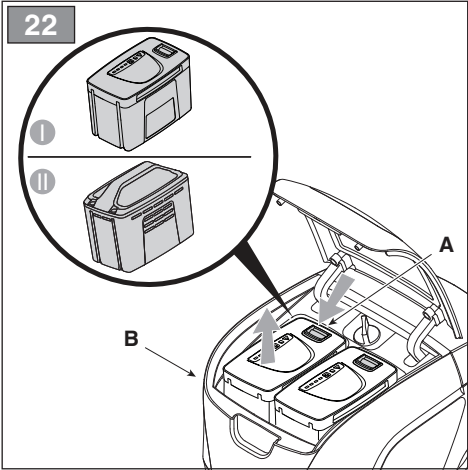
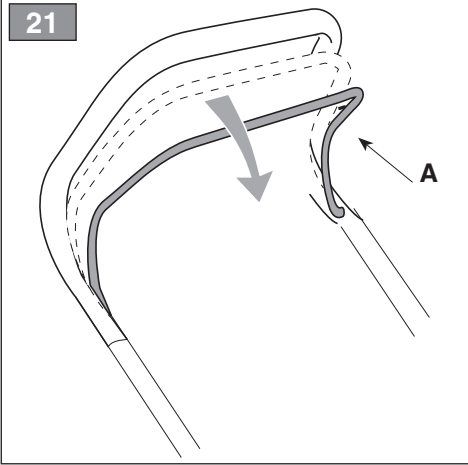

27



B

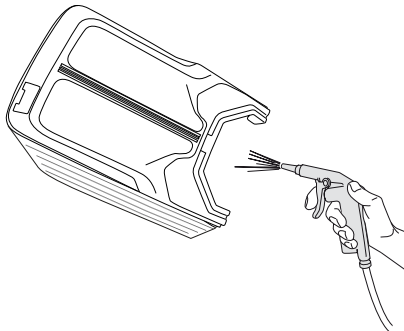

28

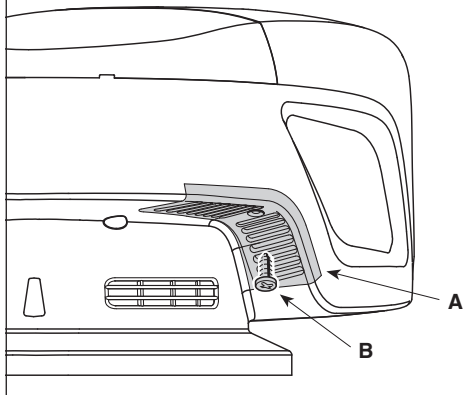

29

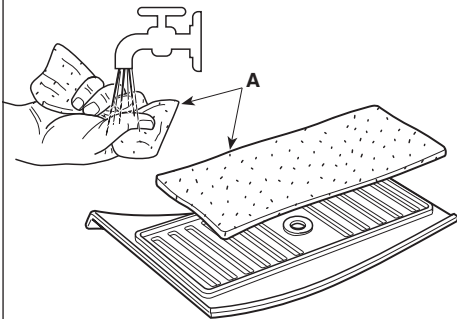

30

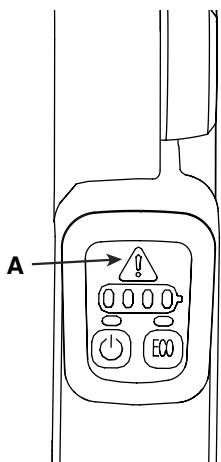

31

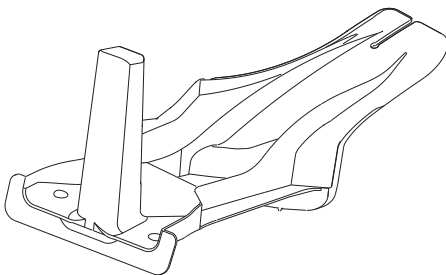

32

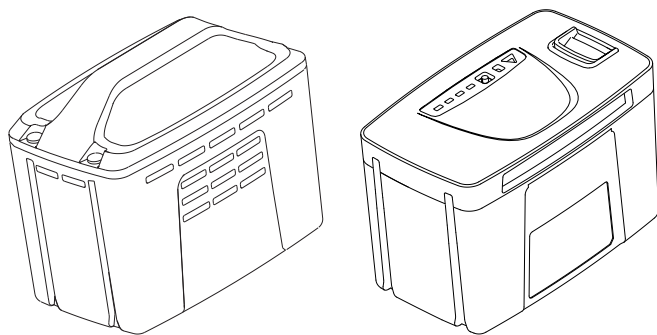

33

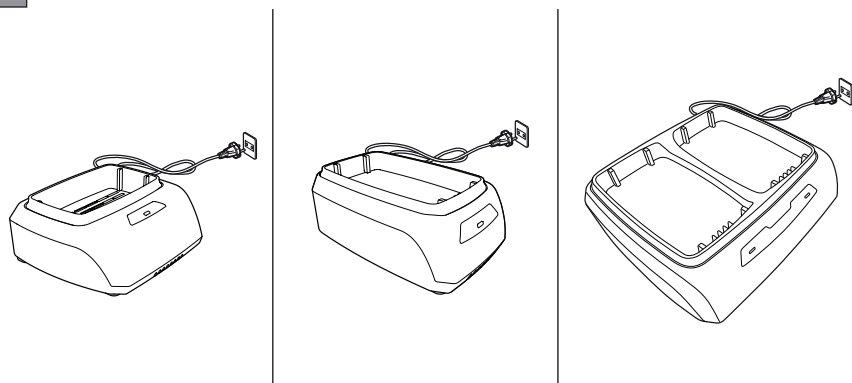

34

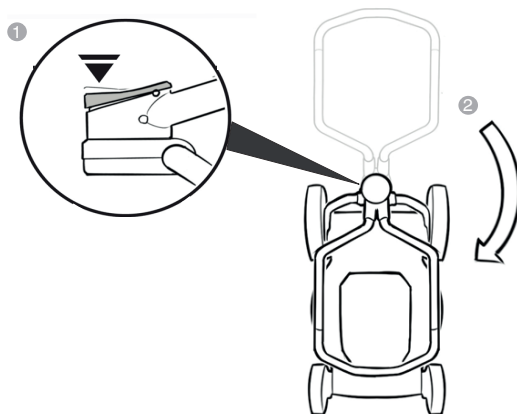

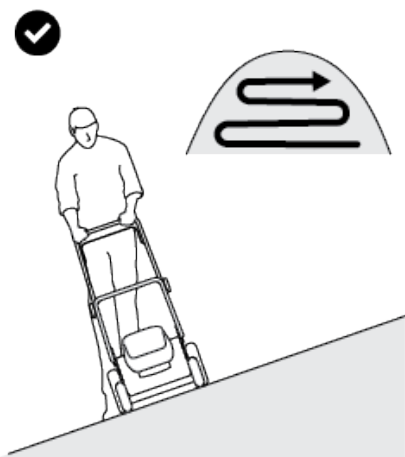
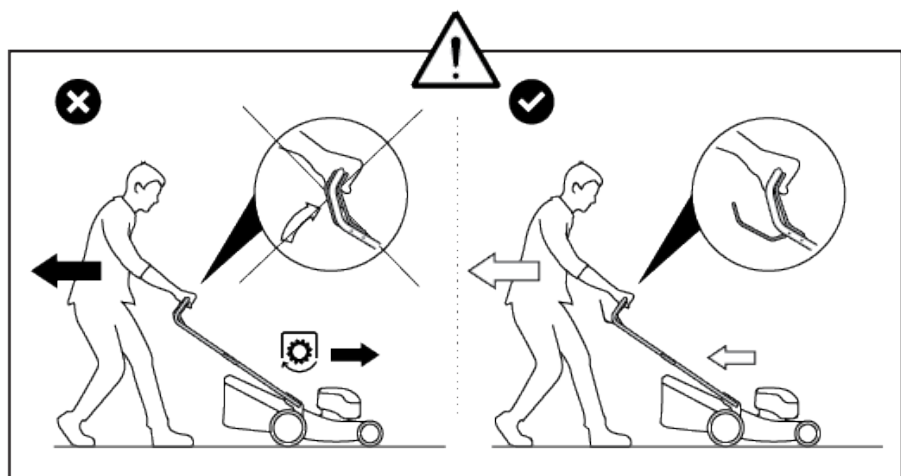
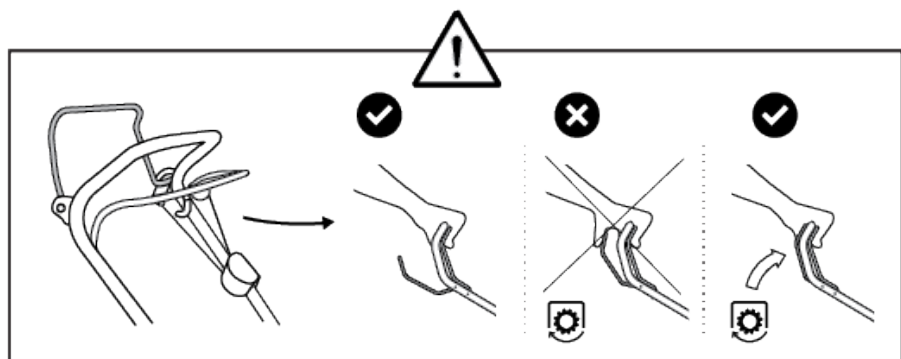



[1]	DATI TECNICI		CP1 430 Li 48 CP1 430 Li D48 Series	CP1 480 Li 48 CP1 480 Li D48 Series	CP1 530 Li D48 Series
[2]	Potenza nominale *	W	1300 ÷ 1500	1300 ÷ 1500	1500
[3]	Velocità mass. di funzionamento motore *	min <sup>-1</sup>	2900	2900	2900
[4]	Tensione di alimentazione MAX	V / DC	48	48	48
[5]	Tensione di alimentazione NOMINAL	V / DC	43,2	43,2	43,2
[6]	Peso macchina *	kg	21 ÷ 25	23 ÷ 30	28 ÷ 31
[7]	Ampiezza di taglio	cm	41	46	51
[8]	Codice dispositivo di taglio		81004341/3	81004460/0 81004346/3	81004459/0 81004462/0
[9]	Livello di pressione acustica	dB(A)	79,8	82,4	83,7
[10]	Incertezza di misura	dB(A)	3,0	3,0	3,0
[11]	Livello di potenza acustica misurato	dB(A)	90,24	94,36	95,6
[10]	Incertezza di misura	dB(A)	1,34	0,99	2,66
[12]	Livello di potenza acustica garantito	dB(A)	92	95	98
[13]	Livello di vibrazioni	m/s <sup>2</sup>	< 2,5	< 2,5	< 2,5
[10]	Incertezza di misura	m/s <sup>2</sup>	1,5	1,5	1,5

\* Per il dato specifico, fare riferimento a quanto indicato nell'etichetta di identificazione della macchina.

[14]	ACCESSORI			
[15]	Kit "mulching"	✓	✓	✓
[16]	Batterie, mod.	BT 520 Li 48 BT 540 Li 48 BT 550 Li 48	BT 720 Li 48 BT 740 Li 48 BT 750 Li 48 BT 775 Li 48	
[17]	Carica batteria, mod.	CG 500 Li 48 CGF 500 Li 48 CGD 500 Li 48	CG 700 Li 48 CGF 700 Li 48 CGD 700 Li 48	

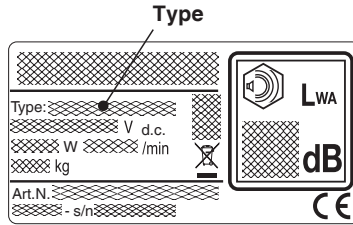

Type:

- CP1 430 Li 48
- CP1 480 Li 48
- CP1 430 Q Li 48
- CP1 480 Q Li 48

BT *20 Li 48	x
BT *40 Li 48	✓
BT *50 Li 48	✓

Type:

- CP1 430 S Li D48
- CP1 480 S Li D48
- CP1 530 S Li D48
- CP1 430 SQ Li D48
- CP1 480 SQ Li D48
- CP1 530 SQ Li D48

BT *20 Li 48	x
BT *40 Li 48	✓
BT *50 Li 48	✓
BT *20 Li 48 + BT *20 Li 48	x
BT *20 Li 48 + BT *40 Li 48	✓
BT *20 Li 48 + BT *50 Li 48	✓
BT *40 Li 48 + BT *40 Li 48	✓
BT *40 Li 48 + BT *50 Li 48	✓
BT *50 Li 48 + BT *50 Li 48	✓

Type:

- CP1 430 A Li D48
- CP1 480 A Li D48
- CP1 430 AQ Li D48
- CP1 480 AQ Li D48

BT *20 Li 48	x
BT *40 Li 48	✓
BT *50 Li 48	✓
BT *20 Li 48 + BT *20 Li 48	✓
BT *20 Li 48 + BT *40 Li 48	✓
BT *20 Li 48 + BT *50 Li 48	✓
BT *40 Li 48 + BT *40 Li 48	✓
BT *40 Li 48 + BT *50 Li 48	✓
BT *50 Li 48 + BT *50 Li 48	✓

Type:

- CP1 480 AS Li D48
- CP1 480 ASQ Li D48
- CP1 530 AS Li D48
- CP1 530 ASQ Li D48

BT *20 Li 48	x
BT *40 Li 48	✓
BT *50 Li 48	✓
BT *75 Li 48	✓
BT *20 Li 48 + BT *20 Li 48	x
BT *20 Li 48 + BT *40 Li 48	✓
BT *20 Li 48 + BT *50 Li 48	✓
BT *20 Li 48 + BT *75 Li 48	✓
BT *40 Li 48 + BT *40 Li 48	✓
BT *40 Li 48 + BT *50 Li 48	✓
BT *40 Li 48 + BT *75 Li 48	✓
BT *50 Li 48 + BT *50 Li 48	✓
BT *50 Li 48 + BT *75 Li 48	✓
BT *75 Li 48 + BT *75 Li 48	✓

\* = 7-5

[1] BATTERIE, mod.	
BT 520 Li 48 →	BT 520/1 Li 48
BT 540 Li 48 →	BT 540/1 Li 48
BT 550 Li 48 →	BT 550/1 Li 48
BT 720 Li 48 →	BT 720/1 Li 48 BT 720/2 Li 48
BT 740 Li 48 →	BT 740/1 Li 48 BT 740/2 Li 48
BT 750 Li 48 →	BT 750/1 Li 48 BT 750/2 Li 48
BT 775 Li 48 →	BT 775/1 Li 48 BT 775/2 Li 48

[2] CARICA BATTERIE, mod.
CG 500 Li 48
CGF 500 Li 48
CGD 500 Li 48
CG 700 Li 48
CGF 700 Li 48
CGD 700 Li 48
CGF C Li 48

BG	[1]	АКУМУЛАТОРИ, модел
BS	[1]	BATERIJE, mod.
CS	[1]	AKUMULÁTOR, mod.
DA	[1]	BATTERIER, mod.
DE	[1]	BATTERIE, Mod.
EL	[1]	ΜΠΑΤΑΡΙΕΣ, μοντ.
EN	[1]	BATTERY, mod.
ES	[1]	BATERÍAS, mod.
ET	[1]	AKU, mud.
FI	[1]	AKUT, malli
FR	[1]	BATTERIES, mod.
HR	[1]	BATERIJE, mod.
HU	[1]	AKKUMULÁTOROK, típus
LT	[1]	AKUMULIATORIAI, mod.
LV	[1]	AKUMULATORI, mod.
MK	[1]	БАТЕРИИ, модели
NL	[1]	ACCU'S, mod.
NO	[1]	BATTERI, mod.
PL	[1]	AKUMULATORY, mod.
PT	[1]	BATERIAS, mod.
RO	[1]	BATERII, mod.
RU	[1]	БАТАРЕИ, мод.
SK	[1]	AKUMULÁTOR, mod.
SL	[1]	BATERIJE, mod.
SR	[1]	BATERIJE, mod.
SV	[1]	BATTERIER, mod.
TR	[1]	BATARYALAR, mod.

BG	[2]	зарядно устройство, модел
BS	[2]	Punjač baterije, mod.
CS	[2]	Nabíječka akumulátoru, mod.
DA	[2]	Batterioplader, mod.
DE	[2]	Batterieladegerät, Mod.
EL	[2]	Φορτιστής μπαταρίας, μοντ.
EN	[2]	Battery charger, mod.
ES	[2]	Cargador de baterías, mod.
ET	[2]	Akulaadija, mud.
FI	[2]	Akkulatori, malli
FR	[2]	Chargeur de batterie, mod.
HR	[2]	Punjač baterije, mod.
HU	[2]	Akkumulátor-töltő, típus
LT	[2]	Akumuliatoriaus kroviklis, mod.
LV	[2]	Akumulatora lādētājs, mod.
MK	[2]	полнач, модели
NL	[2]	Acculader, mod.
NO	[2]	Batterilader, mod.
PL	[2]	Ładowarka akumulatora, mod.
PT	[2]	Carregador de baterias, mod.
RO	[2]	Încărcător de baterie, mod.
RU	[2]	заряжатель, мод.
SK	[2]	Nabíječka akumulátora, mod.
SL	[2]	Akumulatorski polnilnik, mod.
SR	[2]	Punjač, mod.
SV	[2]	Batteriladdare, mod.
TR	[2]	Pil şarj aleti, mod.

<p>[1] <b>BG - ТЕХНИЧЕСКИ ДАННИ</b></p> <p>[2] Номинална мощност *</p> <p>[3] Максимална скорост на функциониране на двигателя *</p> <p>[4] Захранващо напрежение МАКС</p> <p>[5] Захранващо напрежение НОМИНАЛНО</p> <p>[6] Тегло на машината *</p> <p>[7] Широчина на кошене</p> <p>[8] Код на инструмента за рязане</p> <p>[9] Ниво на звукова налгана</p> <p>[10] Несигурност на измерване</p> <p>[11] Измерено ниво на акустична мощност</p> <p>[12] Гарантирано ниво на звукова мощност</p> <p>[13] Ниво на вибрации</p> <p>[14] Аксесоари</p> <p>[15] Комплект за „мулчиране“</p> <p>[16] Акумулатори, модел</p> <p>[17] Зарядно устройство, модел</p> <p>[18] Таблица за правилно съчетаване на батерии</p> <p>* За специфични данни, вижте посоченото на идентификационния етикет на машината.</p>	<p>[1] <b>BS - TEHNIČKI PODACI</b></p> <p>[2] Nazivna snaga *</p> <p>[3] Maks. brzina rada motora *</p> <p>[4] MAKS. napon napajanja</p> <p>[5] NOMINALNI napon napajanja</p> <p>[6] Težina mašine *</p> <p>[7] Širina košenja</p> <p>[8] Šifra rezne glave</p> <p>[9] Razina zvučnog pritiska</p> <p>[10] Mjerna nesigurnost</p> <p>[11] Izmjerena razina zvučne snage</p> <p>[12] Garantovana razina zvučne snage</p> <p>[13] Razina vibracija</p> <p>[14] Dodatna oprema</p> <p>[15] Pribor za mulčiranje</p> <p>[16] Baterije, mod.</p> <p>[17] Punjač baterije, mod.</p> <p>[18] Tabela za ispravnu kombinaciju akumulatora</p> <p>* Za specifični podataka, pogledajte što je navedeno na identifikacijskoj naljepnici mašine.</p>	<p>[1] <b>CS - TECHNICKÉ PARAMETRY</b></p> <p>[2] Jmenovitý výkon</p> <p>[3] Maximální rychlost činnosti motoru *</p> <p>[4] Napájecí napětí MAX</p> <p>[5] Napájecí napětí NOMINÁL</p> <p>[6] Hmotnost stroje *</p> <p>[7] Šifra sečení</p> <p>[8] Kód záchoj strojí</p> <p>[9] Úroveň akustického tlaku</p> <p>[10] Nepřesnost měření</p> <p>[11] Úroveň naměřeného akustického výkonu</p> <p>[12] Úroveň zaručeného akustického výkonu</p> <p>[13] Úroveň vibrací</p> <p>[14] Příslušenství</p> <p>[15] Sada pro Mulčování</p> <p>[16] Akumulátor, mod.</p> <p>[17] Nabíječka akumulátoru, mod.</p> <p>[18] Tabulka pro správnou kombinaci baterií</p> <p>* Ohledně uvedeného údaje vycházejte z hodnoty uvedené na identifikačním štítku stroje.</p>
<p>[1] <b>DA - TEKNISKE DATA</b></p> <p>[2] Nominel effekt *</p> <p>[3] Motorens maks. driftshastighed *</p> <p>[4] Forsyningsspænding MAX</p> <p>[5] Forsyningsspænding NOMINAL</p> <p>[6] Maskinens vægt *</p> <p>[7] Klippebredde</p> <p>[8] Skæreanordningens kode</p> <p>[9] Lydtryksniveau</p> <p>[10] Måleusikkerhed</p> <p>[11] Målt lydeffektniveau</p> <p>[12] Garanteret lydeffektniveau</p> <p>[13] Vibrationsniveau</p> <p>[14] Tilbehør</p> <p>[15] Sæt til "multiclip"</p> <p>[16] Batterier, mod.</p> <p>[17] Batterioplader, mod.</p> <p>[18] Tabel for korrekt kombination af batterier</p> <p>* For disse data henvises til hvad der er angivet på maskinens identifikationsmærkat.</p>	<p>[1] <b>DE - TECHNISCHE DATEN</b></p> <p>[2] Nennleistung *</p> <p>[3] Max. Betriebsgeschwindigkeit des Motors *</p> <p>[4] MAX Versorgungsspannung</p> <p>[5] NOMINALE Versorgungsspannung</p> <p>[6] Maschinengewicht *</p> <p>[7] Schnittbreite</p> <p>[8] Code Schneidvorrichtung</p> <p>[9] Schallpegel</p> <p>[10] Messungengenauigkeit</p> <p>[11] Gemessener Schalleistungspegel</p> <p>[12] Sichergestellter Schalleistungspegel</p> <p>[13] Schwingungen</p> <p>[14] Anbaugeräte</p> <p>[15] Mulching-Kit</p> <p>[16] Batterie, Mod.</p> <p>[17] Batterie ladegerät, Mod.</p> <p>[18] Tabelle für die richtige Kombination der Batterien</p> <p>* Für die genaue Angabe nehmen Sie bitte auf das Typenschild der Maschine Bezug.</p>	<p>[1] <b>EL - TEHNIKA XAPAKTIPCTIKA</b></p> <p>[2] Ονομαστική ισχύς *</p> <p>[3] Μέγ. ταχύτητα λειτουργίας κινητήρα *</p> <p>[4] ΜΕΓ. τάση τροφοδοσίας</p> <p>[5] ΟΝΟΜΑΣΤΙΚΗ τάση τροφοδοσίας</p> <p>[6] Βάρος μηχανήματος *</p> <p>[7] Πλάτος κοπής</p> <p>[8] Κωδικός συστήματος κοπής</p> <p>[9] Στάθμη ακουστικής πίεσης</p> <p>[10] Αβεβαιότητα μέτρησης</p> <p>[11] Μετρημένη στάθμη ακουστικής ισχύος</p> <p>[12] Εγγυημένη στάθμη ηχητικής πίεσης</p> <p>[13] Επίπεδο κραδασμών</p> <p>[14] Αξεσουάρ</p> <p>[15] Σετ "Mulching" (ψιλοτεμαχισμού)</p> <p>[16] Μπαταρίες, μοντ.</p> <p>[17] Φορτιστής μπαταρίας, μοντ.</p> <p>[18] Πίνακας για το σωστό συνδυασμό των μπαταριών</p> <p>* Για το συγκεκριμένο στοιχείο, ελέγξτε τα όσα αναγράφονται στην ετικέτα προσαρμοσμού του μηχανήματος.</p>
<p>[1] <b>EN - TECHNICAL DATA</b></p> <p>[2] Nominal power *</p> <p>[3] Max. motor operating speed *</p> <p>[4] MAX supply voltage</p> <p>[5] NOMINAL supply voltage</p> <p>[6] Machine weight *</p> <p>[7] Cutting width</p> <p>[8] Cutting means code</p> <p>[9] Sound pressure level</p> <p>[10] Measurement uncertainty</p> <p>[11] Measured acoustic power level</p> <p>[12] Guaranteed acoustic power level</p> <p>[13] Vibrations level</p> <p>[14] Accessories</p> <p>[15] Mulching kit</p> <p>[16] Battery, mod.</p> <p>[17] Battery charger, mod.</p> <p>[18] Table for the correct combination of batteries</p> <p>* Please refer to the data indicated on the machine's identification label for the exact figure.</p>	<p>[1] <b>ES - DATOS TÉCNICOS</b></p> <p>[2] Potencia nominal *</p> <p>[3] Velocidad máx. de funcionamiento motor *</p> <p>[4] Tensión de alimentación MAX</p> <p>[5] Tensión de alimentación NOMINAL</p> <p>[6] Peso máquina *</p> <p>[7] Amplitud de corte</p> <p>[8] Código del dispositivo de corte</p> <p>[9] Nivel de presión acústica</p> <p>[10] Incertidumbre de medida</p> <p>[11] Nivel de potencia acústica medido</p> <p>[12] Nivel de potencia acústica garantizado</p> <p>[13] Nivel de vibraciones</p> <p>[14] Accesorios</p> <p>[15] Kit para "Mulching"</p> <p>[16] Baterías, mod.</p> <p>[17] Cargador de batería, mod.</p> <p>[18] Tabla para combinar correctamente las baterías</p> <p>* Para el dato específico, hacer referencia a lo indicado en la etiqueta de identificación de la máquina.</p>	<p>[1] <b>ET - TEHNILISED ANDMED</b></p> <p>[2] Nominaalvõimsus *</p> <p>[3] Mootori töötamise maks. kiirus *</p> <p>[4] MAX toitepinge</p> <p>[5] NOMINAALNE toitepinge</p> <p>[6] Masina kaal *</p> <p>[7] Lõikelaius</p> <p>[8] Lõikeseadme kood</p> <p>[9] Helirõhu tase</p> <p>[10] Mõõtmisevõlvatus</p> <p>[11] Mõõdetud müra võimsuse tase</p> <p>[12] Garanteeritud müra võimsuse tase</p> <p>[13] Vibratsioonide tase</p> <p>[14] Liseseadmed</p> <p>[15] "Multisims" komplekt</p> <p>[16] Aku, mud.</p> <p>[17] Akulaadja, mud.</p> <p>[18] Akude õige kombinatsiooni tabel</p> <p>* Konkreetse info jaoks viidata masina identifitseerimisetiketil märgitule.</p>

<p>[1] <b>FI - TEKNISET TIEDOT</b></p> <p>[2] Nimellisteho *</p> <p>[3] Moottorin maksimaalinen toimintanopeus *</p> <p>[4] MAKS. syöttöjännite</p> <p>[5] NIMELLINEN syöttöjännite</p> <p>[6] Laitteen paino *</p> <p>[7] Leikkuleveys</p> <p>[8] Leikkulaaitteen koodi</p> <p>[9] Akustisen paineen taso</p> <p>[10] Epätarkka mittaus</p> <p>[11] Mitattu äänitehotaso</p> <p>[12] Taattu äänitehotaso</p> <p>[13] Tärinätaaso</p> <p>[14] Lisävarusteet</p> <p>[15] Sarja "mulching"</p> <p>[16] Akut, malli</p> <p>[17] Akkulaturi, malli</p> <p>[18] Tuululokkeiden oikeaoppista yhdistelyä varten</p> <p>* Määrätyt arvoa varten, viittaa laitteen tunnuslaatas- sa annettuihin tietoihin.</p>	<p>[1] <b>FR - CARACTÉRISTIQUES TECHNIQUES</b></p> <p>[2] Puissance nominale*</p> <p>[3] Vitesse max. de fonctionnement du moteur*</p> <p>[4] Tension d'alimentation MAX</p> <p>[5] Tension d'alimentation NOMINALE</p> <p>[6] Poids machine*</p> <p>[7] Largeur de coupe</p> <p>[8] Code organe de coupe</p> <p>[9] Niveau de pression acoustique</p> <p>[10] Incertitude de la mesure</p> <p>[11] Niveau de puissance acoustique mesuré</p> <p>[12] Niveau de puissance acoustique garanti</p> <p>[13] Niveau de vibrations</p> <p>[14] Accessoires</p> <p>[15] Kit de "Mulching"</p> <p>[16] Batteries, mod.</p> <p>[17] Chargeur de batterie, mod.</p> <p>[18] Tableau pour la combinaison correcte des batteries</p> <p>* Pour la valeur spécifique, se référer à ce qui est indi- qué sur la plaque d'identification de la machine.</p>	<p>[1] <b>HR - TEHNIČKI PODACI</b></p> <p>[2] Nazivna snaga*</p> <p>[3] Maks. brzina rada motora*</p> <p>[4] MAKS. napon napajanja</p> <p>[5] NAZIVNI napon napajanja</p> <p>[6] Težina stroja*</p> <p>[7] Širina košnje</p> <p>[8] Šifra noževa</p> <p>[9] Razina zvučnog tlaka</p> <p>[10] Kolebanje mjerjenja</p> <p>[11] Izmjerena razina zvučne snage</p> <p>[12] Zajamčena razina zvučnog tlaka</p> <p>[13] Razina vibracija</p> <p>[14] Dodatna oprema</p> <p>[15] Komplet za "malčiranje"</p> <p>[16] Baterije, mod.</p> <p>[17] Punjač baterija, mod.</p> <p>[18] Tablica za pravilnu kombinaciju baterija</p> <p>* Specifični podatak pogledajte na identifikacijskoj etiketi stroja.</p>
<p>[1] <b>HU - MŰSZAKI ADATOK</b></p> <p>[2] Névleges teljesítmény *</p> <p>[3] A motor max. üzemi sebessége *</p> <p>[4] MAX tápfeszültség</p> <p>[5] NÉVLEGES tápfeszültség</p> <p>[6] A gép tömege *</p> <p>[7] Munkaszélesség</p> <p>[8] Vágószerkezet kódja</p> <p>[9] Hangnyomás szintje</p> <p>[10] Mérésre bizonyságtalanság</p> <p>[11] Mért zajteljesítmény szint</p> <p>[12] Garantiált hangerőszint</p> <p>[13] Vibrációs szint</p> <p>[14] Tartozékok</p> <p>[15] „Mulcsozó” készlet</p> <p>[16] Akkumulátorok, típus</p> <p>[17] Akkumulátortöltő, típusa</p> <p>[18] Táblázat az akkumulátorok helyes kom- binációjához</p> <p>* A pontos adatot lásd a gép azonosító adattábláján.</p>	<p>[1] <b>LT - TECHNINIAI DUOMENYS</b></p> <p>[2] Vardinė galia *</p> <p>[3] Maksimalus variklio veikimo greitis *</p> <p>[4] MAKS. maitinimo įtampa</p> <p>[5] NOMINALI maitinimo įtampa</p> <p>[6] Įrenginio svoris *</p> <p>[7] Pjovimo plotis</p> <p>[8] Pjovimo įrenginio kodas</p> <p>[9] Garso slėgio lygis</p> <p>[10] Matavimo netikslumas</p> <p>[11] Išmatuotas garso galios lygis</p> <p>[12] Garantuotas garso galios lygis</p> <p>[13] Vibracijų lygis</p> <p>[14] Priedai</p> <p>[15] „Mulčiavimo” rinkinys</p> <p>[16] Akumuliatoriai, mod.</p> <p>[17] Akumuliatoriaus įkroviklis, mod.</p> <p>[18] Tinkamo akumuliatorių derinio lentelė</p> <p>* Konkretūs specifiniai duomenys yra pateikti įrenginio identifikavimo etiketėje.</p>	<p>[1] <b>LV - TEHNISKIE DATI</b></p> <p>[2] Nominālā jauda *</p> <p>[3] Maks. dzinēja griešanās ātrums *</p> <p>[4] MAKS. barošanas spriegums</p> <p>[5] NOMINĀLAIS barošanas spriegums</p> <p>[6] Mašīnas svars *</p> <p>[7] Plaušanas platums</p> <p>[8] Griešanas mehānisma kods</p> <p>[9] Skaņas spiediena līmenis</p> <p>[10] Mērijuma kļūda</p> <p>[11] Izmēritais skaņas intensitātes līmenis</p> <p>[12] Garantētais skaņas spiediena līmenis</p> <p>[13] Vibrāciju līmenis</p> <p>[14] Piederumi</p> <p>[15] „Mulčēšanas” komplekts</p> <p>[16] Akumulatori, mod.</p> <p>[17] Akumulatoru lādētājs, mod.</p> <p>[18] Pareizas akumulatoru kombinācijas tabula</p> <p>* Precīza vērtība ir norādīta mašīnas identifikācijas datu plāksnītē.</p>
<p>[1] <b>MK - ТЕХНИЧКИ ПОДАТОЦИ</b></p> <p>[2] Номинална моќност *</p> <p>[3] Максимална брзина при работа на моторот *</p> <p>[4] МАКСИМАЛЕН напон</p> <p>[5] НОМИНАЛЕН напон</p> <p>[6] Тежина на машината *</p> <p>[7] Обем на косење</p> <p>[8] Код на уредот за сечење</p> <p>[9] Ниво на звучен притисок</p> <p>[10] Мерна несигурност</p> <p>[11] Измерено ниво на акустична моќност</p> <p>[12] Ниво на загарантирана звучна моќност</p> <p>[13] Ниво на вибрации</p> <p>[14] Дополнителна опрема</p> <p>[15] Комплет за „мелење“</p> <p>[16] Батерији, модели</p> <p>[17] Полнач за батерија, модел</p> <p>[18] Табела за точната комбинација на батерији</p> <p>* За одреден податок, проверете дали истиот е посочен на етикетата за идентификација на машината.</p>	<p>[1] <b>NL - TECHNISCHE GEGEVENS</b></p> <p>[2] Nominaal vermogen</p> <p>[3] Maximale snelheid voor de werking van de motor *</p> <p>[4] Voedingsspanning MAX</p> <p>[5] Voedingsspanning NOMINAL</p> <p>[6] Gewicht machine *</p> <p>[7] Maatbreedte</p> <p>[8] Code snij-inrichting</p> <p>[9] Niveau geluidsdruk</p> <p>[10] Meetonzekerheid</p> <p>[11] Gemeten akoestisch vermogen</p> <p>[12] Gewaarborgd akoestisch vermogen</p> <p>[13] Niveau trillingen</p> <p>[14] Accessoires</p> <p>[15] Kit "mulching"</p> <p>[16] Accu's, mod.</p> <p>[17] Acculader, mod.</p> <p>[18] Tabel voor de correcte combinatie van de batterijen</p> <p>* Voor het specifiek gegeven, verwijst men naar wat aangegeven is op het identificatielabel van de machine.</p>	<p>[1] <b>NO - TEKNISKE DATA</b></p> <p>[2] Nominell effekt *</p> <p>[3] Motorens maks driftshastighet *</p> <p>[4] MAX forsyningspennning</p> <p>[5] NOMINAL forsyningspennning</p> <p>[6] Maskinvekt *</p> <p>[7] Klippebredde</p> <p>[8] Kode til klippeenheter</p> <p>[9] Nivå for akustisk trykk</p> <p>[10] Måleusikkerhet</p> <p>[11] Målt lydeffektivt</p> <p>[12] Garantert lydeffektivt</p> <p>[13] Vibrasjonsnivå</p> <p>[14] Tilbehør</p> <p>[15] Sett for "mulching"</p> <p>[16] Batteri, mod.</p> <p>[17] Batterilader, mod.</p> <p>[18] Tabell for korrekt kombinasjon av batteriene</p> <p>* For spesifikk informasjon, se referansen på maski- nens identifikasjonsetikett.</p>

<p><b>[1] PL - DANE TECHNICZNE</b></p> <p>[2] Moc znamionowa *</p> <p>[3] Maks. predkość obrotowa silnika *</p> <p>[4] Napięcie zasilania MAKŚ</p> <p>[5] Napięcie zasilania ZNAMIONOWE</p> <p>[6] Masa maszyny *</p> <p>[7] Szerokość koszenia</p> <p>[8] Kod urządzenia tnącego</p> <p>[9] Poziom ciśnienia akustycznego</p> <p>[10] Niepewność pomiaru</p> <p>[11] Poziom mocy akustycznej zmierzony</p> <p>[12] Gwarantowany poziom mocy akustycznej</p> <p>[13] Poziom vibracji</p> <p>[14] Akcesoria</p> <p>[15] Zestaw mulczujący</p> <p>[16] Akumulatory, mod.</p> <p>[17] Ladowarka akumulatora, mod.</p> <p>[18] Tabela prawidłowego połączenia akumulatorów</p> <p>* W celu uzyskania konkretnych danych, należy się odnieść do wskazań zamieszczonych na tabliczce identyfikacyjnej maszyny.</p>	<p><b>[1] PT - DADOS TÉCNICOS</b></p> <p>[2] Potência nominal *</p> <p>[3] Velocidade máx. de funcionamento motor *</p> <p>[4] Tensão de alimentação MÁX</p> <p>[5] Tensão de alimentação NOMINAL</p> <p>[6] Peso da máquina *</p> <p>[7] Amplitude de corte</p> <p>[8] Código do dispositivo de corte</p> <p>[9] Nivel de pressão acústica</p> <p>[10] Incerteza de medição</p> <p>[11] Nivel de potência acústica medido</p> <p>[12] Nivel de potência acústica garantido</p> <p>[13] Nivel de vibrações</p> <p>[14] Acessórios</p> <p>[15] Kit "Mulching"</p> <p>[16] Baterias, mod.</p> <p>[17] Carregador de bateria, mod.</p> <p>[18] Tabela para a combinação correta das baterias</p> <p>* Para o dado específico, consultar a etiqueta de identificação da máquina.</p>	<p><b>[1] RO - DATE TEHNICE</b></p> <p>[2] Putere nominală *</p> <p>[3] Viteza max. de funcționare a motorului *</p> <p>[4] Tensiune de alimentare MAX</p> <p>[5] Tensiune de alimentare NOMINALĂ</p> <p>[6] Greutatea mașinii *</p> <p>[7] Lățimea de tăiere</p> <p>[8] Codul dispozitivului de tăiere</p> <p>[9] Nivel de presiune acustică</p> <p>[10] Nesiguranță în măsurare</p> <p>[11] Nivel de putere acustică măsurat</p> <p>[12] Nivel de putere acustică garantat</p> <p>[13] Nivel de vibrații</p> <p>[14] Accesorii</p> <p>[15] Kit de mărunțire „Mulching”</p> <p>[16] Baterii, mod.</p> <p>[17] Încărcător, mod.</p> <p>[18] Tabel pentru combinarea corectă a bateriilor</p> <p>* Pentru informația specifică, consultați datele de pe eticheta de identificare a mașinii.</p>
<p><b>[1] RU - ТЕХНИЧЕСКИЕ ХАРАКТЕРИСТИКИ</b></p> <p>[2] Номинальная мощность *</p> <p>[3] Макс. число оборотов двигателя *</p> <p>[4] МАКС. напряжение питания</p> <p>[5] НОМИНАЛЬНОЕ напряжение питания</p> <p>[6] Вес машины *</p> <p>[7] Ширина скашивания</p> <p>[8] Артикул режущего приспособления</p> <p>[9] Уровень звукового давления</p> <p>[10] Неточность размеров</p> <p>[11] Измеренный уровень звуковой мощности</p> <p>[12] Гарантированный уровень звуковой мощности</p> <p>[13] Уровень вибрации</p> <p>[14] Дополнительное оборудование</p> <p>[15] Комплект "Мульчирование"</p> <p>[16] Батареи, мод.</p> <p>[17] Зарядное устройство, мод.</p> <p>[18] Таблица правильной комбинации батареек</p> <p>* Точное значение см. на идентификационном ярлыке машины.</p>	<p><b>[1] SK - TECHNICKÉ PARAMETRE</b></p> <p>[2] Menovitý výkon *</p> <p>[3] Maximálna rýchlosť činnosti motora *</p> <p>[4] MAX. napájacie napätie</p> <p>[5] NOMINÁLNE napájacie napätie</p> <p>[6] Hmotnosť stroja *</p> <p>[7] Šírka kosenia</p> <p>[8] Kód kosiaceho zariadenia</p> <p>[9] Úroveň akustického tlaku</p> <p>[10] Nepresnosť merania</p> <p>[11] Úroveň nameraného akustického výkonu</p> <p>[12] Úroveň zaručeneho akustického výkonu</p> <p>[13] Úroveň vibrácií</p> <p>[14] Príslušenstvo</p> <p>[15] Súprava pre Mulčovanie</p> <p>[16] Akumulátor, mod.</p> <p>[17] Nabíjačka akumulátora, mod.</p> <p>[18] Tabuľka pre správnu kombináciu batérií</p> <p>* Ohľadne uvedeného parametra vychádzajte z hodnoty uvedenej na identifikačnom štítku stroja.</p>	<p><b>[1] SL - TEHNIČNI PODATKI</b></p> <p>[2] Nazivna moč *</p> <p>[3] Najvišja hitrost delovanja motorja *</p> <p>[4] Največja napetost električnega napajanja</p> <p>[5] Nazivna napetost električnega napajanja</p> <p>[6] Teža stroja *</p> <p>[7] Širina reza</p> <p>[8] Šifra rezalne naprave</p> <p>[9] Raven zvočnega tlaka</p> <p>[10] Nezasnesljivost meritev</p> <p>[11] Izmerjena raven zvočne moči</p> <p>[12] Raven zajamčene jakosti zvoka</p> <p>[13] Nivo vibracij</p> <p>[14] Dodatna oprema</p> <p>[15] Komplet za mulčenje</p> <p>[16] Baterije, mod.</p> <p>[17] Polnilnik baterije, mod.</p> <p>[18] Tabela s pravilnimi kombinacijami baterij</p> <p>* Za specifični podatek glej identifikacijsko nalepko stroja.</p>
<p><b>[1] SR - TEHNIČKI PODACI</b></p> <p>[2] Nazivna snaga *</p> <p>[3] Maks. radna brzina motora *</p> <p>[4] Napon napajanja MAKŚ</p> <p>[5] Napon napajanja NOMINALNI</p> <p>[6] Težina mašine *</p> <p>[7] Širina košenja</p> <p>[8] Kod rezne glave</p> <p>[9] Nivo zvučnog pritiska</p> <p>[10] Nepouzdanost merenja</p> <p>[11] Izmereni nivo zvučne snage</p> <p>[12] Garantovani nivo akustične snage</p> <p>[13] Nivo vibracija</p> <p>[14] Dodatna oprema</p> <p>[15] Oprema za „mulčiranje”</p> <p>[16] Baterije, mod.</p> <p>[17] Punjač baterije, mod.</p> <p>[18] Tabela za ispravno kombinovanje baterija</p> <p>* Za specifični podatak, pogledajte podatke navedene na identifikacijskoj nalepnici mašine.</p>	<p><b>[1] SV - TEKNISKA SPECIFIKATIONER</b></p> <p>[2] Nominell effekt *</p> <p>[3] Motorns maximala funktionshastighet *</p> <p>[4] Matningsspänning MAX</p> <p>[5] Matningsspänning NOMINAL</p> <p>[6] Maskinikt *</p> <p>[7] Skårbredd</p> <p>[8] Klippredskapets kod</p> <p>[9] Ljudtrycksnivå</p> <p>[10] Tvivel med mått</p> <p>[11] Uppmått ljudeffektivå</p> <p>[12] Garanterad ljudeffektivå</p> <p>[13] Vibrationsnivå</p> <p>[14] Tillbehör</p> <p>[15] Sats för "Mulching"</p> <p>[16] Batterier, mod.</p> <p>[17] Batteriladdare, mod.</p> <p>[18] Tabell för korrekt kombinerav av batterierna</p> <p>* För specifik information, se uppgifterna på maskinens märklåt.</p>	<p><b>[1] TR - TEKNİK VERİLER</b></p> <p>[2] Nominal güç *</p> <p>[3] Motorun maksimum çalışma hızı *</p> <p>[4] MAKŚ. besleme gerilimi</p> <p>[5] NOMİNAL besleme gerilimi</p> <p>[6] Makine ağırlığı *</p> <p>[7] Kesim genişliği</p> <p>[8] Kesim düzeni kodu</p> <p>[9] Ses basınç seviyesi</p> <p>[10] Ölçü belirsizliği</p> <p>[11] Ölçülen ses gücü seviyesi</p> <p>[12] Garanti edilen ses gücü seviyesi</p> <p>[13] Titreşim seviyesi</p> <p>[14] Aksesuarlar</p> <p>[15] "Malçlama" kiti</p> <p>[16] Bataryalar, mod.</p> <p>[17] Batarya şarj cihazı, mod.</p> <p>[18] Doğru akü kombinasyonuna yönelik tablo</p> <p>* Spesifik değer için, makine belirlenme etiketinde gösterilenleri referans alın.</p>



## INDEX

1. GENERAL INFORMATION .....	1
1.1 How to read the manual .....	1
1.2 References .....	1
2. SAFETY REGULATIONS .....	1
2.1 Training .....	1
2.2 Preliminary procedures .....	2
2.3 During operation .....	2
2.4 Maintenance, storage .....	2
2.5 Battery / battery charger .....	2
2.6 Environmental protection .....	3
3. GETTING TO KNOW THE MACHINE .....	3
3.1 Description of the machine and planned use .....	3
3.2 Safety signs .....	3
3.3 Identification label .....	4
3.4 Main components .....	4
4. ASSEMBLY .....	4
4.1 Unpacking (Fig.3) .....	4
4.2 Handle assembly .....	5
4.3 GRASS CATCHER assembly .....	5
5. CONTROLS .....	5
5.1 Safety key (Deactivation device) .....	5
5.2 Handle .....	5
5.3 Cutting height adjustment .....	5
6. USING THE MACHINE .....	5
6.1 Preliminary procedures .....	5
6.2 Safety checks .....	6
6.3 Start-up .....	6
6.4 Operation .....	7
6.5 Stopping the machine .....	7
6.6 After operation .....	7
7. MAINTENANCE .....	7
7.1 General information .....	7
7.2 BATTERY .....	7
7.3 CLEANING .....	8
7.4 Nuts and bolts .....	8
7.5 Cleaning the air filter .....	8
8. OCCASIONAL MAINTENANCE .....	8
8.1 Cutting means .....	8
9. STORAGE .....	9
9.1 Storing the machine .....	9
9.2 Storing the battery .....	9
10. HANDLING AND TRANSPORTATION .....	9
11. MAINTENANCE TABLE .....	9
12. Problem identification .....	10
12.1 For machines with electronic control .....	10
12.2 For machines WITHOUT electronic control .....	11
13. ATTACHMENTS ON REQUEST .....	12
13.1 "Mulching" kit .....	12
13.2 Batteries .....	12
13.3 Battery charger .....	12

## 1. GENERAL INFORMATION

### 1.1 HOW TO READ THE MANUAL

Some paragraphs in the manual contain important information regarding safety and operation and are emphasised in this manner:

**NOTE OR IMPORTANT** *these give details or further information on what has already been indicated, and aim to prevent damage to the machine.*

This symbol  indicates danger. Failure to observe the warning can lead to possible personal and/or third party injury and/or damage.

\* The paragraphs highlighted with a grey dotted square indicate the optional characteristics that are not available on all models documented in this manual. Check if the characteristics are available on this model.

Whenever reference is made to a position on the machine "front", "back", "left" or "right" hand side, this refers to the operator's working position.

### 1.2 REFERENCES

#### 1.2.1 Figures

The figures in these instructions for use are numbered 1, 2, 3, etc.

The components indicated in the figures are identified with letters A, B, C, and so on.

Reference to component C in figure 2 is indicated with the wording: "See fig. 2.C" or simply "(Fig. 2.C)".

The figures are given as a guide only. The actual pieces can differ from those illustrated in this document.

#### 1.2.2 Titles

The manual is divided into chapters and paragraphs. The title of paragraph '2.1 Training' is a sub-title of "2. Safety regulations".

References to titles or paragraphs are marked with the abbreviation chap. or par. and the relevant number. Example: "chap. 2" or "par. 2.1"

## 2. SAFETY REGULATIONS

### 2.1 TRAINING

 **Become acquainted with the controls and the proper use of the machine. Learn how to stop the motor quickly. Failure to follow the warnings and instructions may result in fire and/or serious injury.**

- Never allow children or persons unfamiliar with these instructions to use the machine. Local laws may establish a minimum age for users.
- This appliance can be used by children aged from 8 years and above and persons with reduced physical, sensory or mental capabilities or lack of experience and knowledge if they have been given supervision or instructions concerning use of the appliance in a safe way and understand the hazards involved. Children shall not play with the appliance. Cleaning and user maintenance shall not be made by children without supervision.



- Never use the machine if the user is tired or unwell, or has taken medicine, drugs, alcohol or any substances which may slow their reflexes and compromise his judgement.
- Do not allow children or other passengers to ride on the machine.
- Bear in mind that the operator or user is responsible for accidents or unexpected events occurring to other people or their property. It is the user's responsibility to assess the potential risk of the area where work is to be carried out and to take all the necessary precautions to ensure his own safety and that of others, particularly on slopes or rough, slippery and unstable ground.
- If the machine is sold or lent to others, make sure that the operator reads the user instructions contained in this manual.

## 2.2 PRELIMINARY PROCEDURES

### Personal Protective Equipment (PPE)

- Always wear suitable work attire, hard-wearing safety footwear with non-slip soles and long trousers. Do not operate the machine barefoot or wearing open sandals. Wear hearing protection devices.
- Use of hearing protections can reduce the ability to hear any warnings (shouting or alarms). Be careful of what occurs around you in the work area.
- Wear protective gloves whenever your hands are at risk.
- Never wear scarves, shirts, necklaces, bracelets, loose flowing clothing, laces or ties or any hanging or flapping accessory that could get caught in the machine or in any objects or materials in the work area.
- Tie your hair back if it is long.

### Work area/Machine

- Thoroughly inspect the entire work area and remove anything that could be thrown by the machine or damage the cutting means/rotating units (stones, branches, iron wire, bones, etc.).

## 2.3 DURING OPERATION

### Work Area

- Do not use the machine in environments at risk of explosion, in the presence of flammable liquids, gas or powder. Power tools create sparks which may ignite the dust or fumes.
- Work only in daylight or with good artificial light in good visibility conditions.
- Keep persons, children and animals away from the working area. Children must be supervised by another adult.
- Avoid working with wet grass, in the rain and when there is a risk of a thunderstorm, especially lightning.
- Do not expose the machine to rain or wet environments. Water entering a power tool will increase the risk of electric shock.
- Pay careful attention to uneven ground (hills, dips), slopes, hidden hazards and obstacles that could limit visibility.
- Be very careful near ravines, ditches or embankments. The machine could overturn if a wheel slides over the edge or if the earth gives way.
- Always mow across a slope and never up and down it, being very careful when changing direction, making sure you have firm footage and that the wheels do not hit any obstacles (such as stones, branches, roots, etc.) that may cause the machine to slide sideways or make you lose control of it.
- Look out for traffic when using the machine near the road.

### Behaviour

- Exercise caution when reversing or moving backwards. Look behind you to make sure there are no obstacles before and during operations in reverse gear.
- Never run, always walk.
- Do not allow the lawnmower to pull you along.
- Always keep hands and feet away from the cutting means, when starting and when using the machine.
- Attention: the cutting means will continue to rotate for a few seconds after disengagement or after you have switched off the motor.
- Keep away from the discharge opening.

**⚠** *If something breaks or an accident occurs during mowing, turn off the motor immediately and move the machine away to prevent further damage; if an accident occurs with injuries or third parties are injured, carry out the first aid measures most suitable for the situation immediately and contact the medical authorities for any necessary health care. Carefully remove any debris which could cause damage or injury to persons or animals if ignored.*

### Use limitations

- Never operate the machine with guards damaged, missing or incorrectly assembled (grass catcher, side discharge guards, rear discharge guards).
- Don't use the machine if the attachments/tools are not installed in their seats.
- Never disengage, deactivate, remove or tamper with the safety systems/micro switches installed.
- Do not strain the machine too much and do not use a small machine for heavy-duty work; if you use the right machine, you will reduce the risk of hazards and improve the quality of your work.

## 2.4 MAINTENANCE, STORAGE

Ensure regular maintenance and correct storage to maintain machine safety and high performance levels.

### Maintenance

- Never use the machine with worn or damaged parts. Faulty or worn-out parts must always be replaced and never repaired.
- Be careful during adjustment of the machine to prevent entrapment of the fingers between moving parts of the cutting means and fixed parts of the machine.

**⚠** *The noise and vibration levels shown in these instructions are the maximum levels for use of the machine. The use of an unbalanced cutting element, the excessive speed of movement, or lack of maintenance have a significant influence on noise emissions and vibrations. Consequently, it is necessary to take preventive steps to eliminate possible damage due to high levels of noise and stress from vibration; Maintain the machine well, wear ear protection devices, and take breaks while working.*

### Storage

- To reduce fire risks, do not leave containers with debris inside a room.

## 2.5 BATTERY / BATTERY CHARGER

**IMPORTANT** *The following safety instructions are in addition to the safety requirements provided in the specific battery and battery charger manual delivered with this machine.*

- Only use battery chargers recommended by the manufacturer to recharge batteries. An inadequate battery charger may cause electric shock, overheating or corrosive liquid to leak from the battery.
- Use only batteries specifically designed for your power tool. The use of other batteries may cause injuries and fire risks.
- Make sure that the machine is switched off before inserting the battery. Inserting a battery in a machine which is switched on can cause a fire.
- Keep all unused batteries at a distance from paper clips, coins, keys, nails, screws or other small metal objects as contact with the same can cause short circuits. Short circuits between battery contacts can lead to explosion or fires.
- Do not use the battery charger in places where there are inflammable vapours, substances or on easily inflammable surfaces like paper, fabric, etc. During recharge, the battery charger becomes heated and may cause fire.
- When transporting accumulators, make sure the contacts never come into contact with each other and never use metal containers to transport them.

## 2.6 ENVIRONMENTAL PROTECTION

Safeguarding the environment must be a relevant and priority aspect of machine use, of benefit to the community and the environment we live in.

- Avoid being a disturbance to the neighbourhood. Use this machine at reasonable times of the day only (not early morning or late evening when the noise could cause disturbance).
- Comply with local regulations for the disposal of packaging, deteriorated parts or any elements with a strong environmental impact; this waste must not be disposed of with regular waste, but must be separated and taken to collection centres, which will recycle the materials.
- Comply with local regulations for the disposal of waste materials.
- When the machine is decommissioned, do not dispose of it in the environment, but take it to a waste disposal facility in accordance with the local regulations in force.



**Do not throw electrical equipment away with domestic waste.** In observance of European Directive 2012/19/EU on electrical and electronic equipment waste and its implementation, in observance of UK Regulation "The waste electrical and electronic equipment regulations 2013 (as amended)" and in accordance with national regulations, old electrical equipment must be collected separately, for eco-compatible recycling. If electrical equipment is disposed of in dumps or in landfills, hazardous substances can leak into the groundwater and contaminate the food chain, damaging your health and well-being. For further information on the disposal of this product, contact your dealer or a domestic waste collection service.



**At the end of their working life, dispose of batteries paying due attention to the environment.** Batteries contain material classified as hazardous for you and the environment. They must be removed and disposed of separately at a facility that accepts lithium-ion batteries.



**Separate waste collection of the products and packaging used allows the materials to be recycled and reused.** Reuse of recycled materials help to prevent environmental pollution and reduces the demand for raw materials.

## 3. GETTING TO KNOW THE MACHINE

### 3.1 DESCRIPTION OF THE MACHINE AND PLANNED USE

**This machine is pedestrian-controlled lawnmower.**

The machine is essentially composed of a motor which drives a cutting means enclosed in a casing, equipped with wheels and a handle.

The operator is able to operate the machine and use the main controls, always staying behind the handle at a safe distance from the rotating cutting means.

If the operator leaves the machine, the motor and cutting means will stop within a few seconds.

#### 3.1.1 Intended use

This machine is designed and built to cut (and collect) grass in gardens and grassy areas, with a height according to its cutting capacity, driven by an operator walking behind it. Generally speaking this machine can:

1. Mow the grass and collect it in the grass catcher bag.
2. Mow the grass and discharge it on the ground through the rear part.
3. Mow the grass and discharge it on the ground laterally (if available).
4. Mow the grass, chop it and discharge it on the ground (mulching effect - if available).

The use of special attachments provided for by the Manufacturer as original equipment or which may be purchased separately, allows this work to be done in various operating modes, illustrated in this manual or the instructions that accompany the single attachments.

#### 3.1.2 Improper use

Any other usage not in keeping with the afore-mentioned ones may be hazardous and harm persons and/or damage things.

Examples of improper use may include, but are not limited to:

- Allowing children, animals or other passengers to ride on the machine as they could fall off and injure themselves or compromise safe driving by the operator.
- Letting oneself be transported by the machine.
- Using the machine to tow or push loads.
- Using the cutting means on surfaces other than grass.
- Use the machine for leaf or debris collection.
- Using the machine to trim hedges, or for cutting vegetation other than grass.
- Use of the machine by more than one person.

**IMPORTANT** *Improper use of the machine will invalidate the warranty, relieve the Manufacturer from all liabilities, and the user will consequently be liable for all and any damage or injury to himself or others.*

#### 3.1.3 User types











This machine is intended for use by consumers, i.e. non-professional operators.



It is intended for "DIY" use only.



**IMPORTANT** *The machine must be used exclusively by one operator.*

## 3.2 SAFETY SIGNS

The machine has various symbols on it (Fig. 2). Their function is to remind the operator of the correct conduct for use, with due care and caution. Meanings of the symbols:

-   **Warning.** Read the instructions before operating the machine.
-   **Danger! Risk of thrown objects.** Keep all persons away from the work area whilst working.
-   Only for lawn mowers with thermal engine.
-   Only for electric lawn mowers with mains power supply.
-   Only for electric lawn mowers with mains power supply.

  **Danger! Danger of cutting.** Cutting means in motion. Do not insert hands or feet into the cutting means housing.

  **Be careful when using the sharp cutting means.** Do not put hands or feet near or under the opening of the cutting means. The cutting means continues to turn even after the motor has been switched off. Remove the safety key (deactivation device) before any maintenance is carried out.

**IMPORTANT** Any damaged or illegible decals must be replaced. Order replacement decals from an Authorised Service Centre.

### 3.3 IDENTIFICATION LABEL

The identification label holds the following data (Fig.1).

1. Sound power level.
2. Conformity marking.
3. Year of manufacture.
4. Type of machine.
5. Serial number.
6. Name and address of Manufacturer.
7. Article code.
8. Max. motor operation speed.
9. Weight in kg.
10. Power voltage and frequency.
11. Electrical protection rating.
12. Nominal power.

Write the identification data of the machine in the specific space on the label on the back of the cover page.

**IMPORTANT** Quote the information on the product identification label whenever you contact an Authorised Service Centre.

**IMPORTANT** The example of the Declaration of Conformity is provided on the last pages of the manual.

### 3.4 MAIN COMPONENTS

The machine is composed of a series of main components that have the following functions (Fig.1.0):

- A. **Chassis:** this is the casing that houses the rotating cutting means.
- B. **The engine:** drives both the cutting means and the wheel traction (if available).
- C. **Cutting means:** the element designed to cut the grass.

- D. **Rear discharge guard:** it is a safety device which prevents objects collected by the cutting means from being projected away from the machine.
- E. **Side discharge guard (if available):** it is a safety device which prevents objects collected by the cutting means from being projected away from the machine.
- F. **Side discharge chute (if available):** apart from discharging the grass on the ground laterally, it also constitutes a safety element, preventing any objects collected by the cutting means from being projected away from the machine.
- G. **Grass catcher:** apart from collecting the mown grass, the grass catcher also constitutes a safety element, preventing any objects collected by the cutting means from being projected away from the machine.
- H. **Handle:** this is the operator's work station. It is long enough to ensure the operator remains at a safe distance from the rotary cutting means whilst working.
- I. **Battery** (if it is not supplied with the machine, see chapter 13 "attachments on request"): provides the energy for starting the motor; its specifications and regulations for use are described in a specific manual.
- J. **Operator presence lever:** this lever enables the cutting means and drive to be operated. The engine stops automatically when the lever is released.
- K. **Drive engagement lever (if available):** this lever engages the drive to the wheels and allows the machine to move forward.
- L.  **Hatch for accessing the battery compartment**
- M. **Safety key (Deactivation device):** The key enables / disables the machine electric circuit.
- N. **Battery charger** (if it is not supplied with the machine, see chapter 13 "attachments on request"): device used to recharge the battery.

 **Strictly observe the indications and the safety regulations described in chap. 2.**

## 4. ASSEMBLY

Certain components of the machine are not installed in the factory and have to be assembled after unpacking, following the instructions below.

 **Unpacking and completing the assembly should be performed on a flat and stable surface, with enough space for handling the machine and its packaging. Do not use the machine until all the indications provided in the "ASSEMBLY" section have been carried out.**

### 4.1 UNPACKING (FIG.3)

1. Carefully open the packaging, paying attention not to lose components.
2. Consult the documentation in the box, including these instructions.
3. Remove all the unassembled parts from the box.

- Dispose of the box and packaging in compliance with local regulations.

 **Before assembling, make sure the safety key is not inserted into its housing.**

#### 4.2 HANDLE ASSEMBLY

Assemble the handle according to the indications in (Fig.4).

#### 4.3 GRASS CATCHER ASSEMBLY

Assemble the grass catcher as illustrated in (Fig.5).

### 5. CONTROLS

#### 5.1 SAFETY KEY (DEACTIVATION DEVICE)

The key (Fig.6.A) found inside the battery compartment enables / disables the machine's electrical circuit. Removing the key, the electric circuit is completely deactivated to prevent uncontrolled use of the machine.

**IMPORTANT** *Remove the safety key whenever the machine is unused or left unattended.*

- For certain models, if required, turn the key to "ON" position to activate the electric circuit of the machine to activate its start-up.
- Turning the key to "OFF", the electric circuit of the machine is completely deactivated, to prevent any uncontrolled use of the machine.

#### 5.2 HANDLE

##### 5.2.1 Operator presence lever

The operator presence lever (Fig.7.A) enables the cutting means.

It is located in front of the handle.

Press the safety button (Fig.7.C) and bring the lever towards the handle in order to start the cutting means.

When the lever is released, the motor automatically stops and all functions are disabled.

**NOTE** *The cutting means engagement is possible only by pressing the yellow button on the right side of the handle and bringing the operator presence lever towards the handle.*

##### 5.2.2 Power button (if provided)

The power button (Fig.8.A) is used to:



- Machine start-up.** By pressing the button (Fig.8.A) the LED (Fig.8.B) switches on and the machine is ready for use.

**NOTE** *The machine can be switched on only if the operator presence lever and the drive lever are released.*

**NOTE** *In case the machine is not operated, the LED switches off after 15 seconds and the above-mentioned operation must be carried out again.*



- Cutting means engagement.**

**NOTE** *The cutting means engagement is possible only by pressing the operator presence lever on the handle (see par. 6.3).*

- Cutting means disengagement.** With the cutting means engaged, release the operator presence lever (Fig.7.A); the cutting means stops whilst keeping the machine powered on.

##### 5.2.3 Drive ON lever

**IMPORTANT** *The engine has to be always started with the drive disengaged.*

This engages the wheel drive and allows the machine to move forward.

It is located behind the handle.



**Drive engaged.** The lawn mower is driven forward with the lever pulled against the handle (Fig.7.A). The lawn mower stops moving forward when the lever is released.

**IMPORTANT** *Avoid moving the machine backwards when the drive is ON.*

For certain models, the forward speed can be adjusted with the selection knob located on the right side of the handle (Fig.8.C).

You can select 6 different levels of speed.



- Maximum speed** (about 5 Km/h).



- Minimum speed** (about 2.5 Km/h).

**NOTE** *The last speed level selected remains set even after the machine is switched off.*

##### 5.2.4 "ECO" button (if provided)

The "ECO" mode allows to save energy when cutting the grass, optimising the battery life. Press the button (Fig.8.D) to enable or disable the "Eco" mode.

This mode is automatically deactivated when the operator presence levers are released.

**NOTE** *It is not recommended to use the "ECO" function in heavy grass cutting conditions (cutting of dense, high, humid grass).*

### 5.3 CUTTING HEIGHT ADJUSTMENT

Lower or raise the chassis to cut the grass at different heights.



**Carry out this operation when the cutting means is stationary.**

The cutting height is adjusted by using the designated lever (Fig.9.A) that lifts or lowers the chassis to the desired position.

### 6. USING THE MACHINE

**IMPORTANT** *For instructions regarding the batteries, refer to the specific manual.*

#### 6.1 PRELIMINARY PROCEDURES

Make sure that the safety key is not inserted in its slot. Place the machine in a stable horizontal position on the ground.

### 6.1.1 Checking the battery

Before using the machine for the first time after purchase, fully charge the battery following the instructions in the battery booklet.

Before every use of the machine, check the battery charge status according to the instructions in the battery booklet.

### 6.1.2 Preparing the machine before starting work

**NOTE** This machine can be used to mow lawns in various ways.

#### a. Preparation for grass cutting and collection in the grass catcher:

1. For side discharge models: make sure that the guard (Fig. 10.A) is lowered and locked by the safety lever (Fig. 10.B).
2. Insert the grass catcher (Fig.10.C).

#### b. Preparation for grass cutting and rear grass discharge on the ground:

1. Lift the rear discharge guard (Fig.11.A) and fit the pin (Fig.11.B).
2. For models with side discharge option: make sure that the guard (Fig. 11.C) is lowered and locked by the safety lever (Fig. 11.D).

To remove the pin: see Fig.11.A/B.

#### c. Preparation for grass mowing and chopping (mulching function):

Lift the rear discharge guard (Fig.12.A) and insert the chute plug (Fig.12.B) in the discharge opening, keeping it slightly tilted to the right; then fasten it by inserting the two pins (Fig.12.B.1) in the provided holes, until the engagement click is heard.

For models with side discharge option: make sure that the side discharge guard (Fig. 12.C) is lowered and locked by the safety lever (Fig. 12.D).

#### d. Preparation for grass cutting and side discharge on the ground:

1. Lift the rear discharge guard (Fig.13.A) and insert the chute plug (Fig.13.B) in the discharge opening, keeping it slightly tilted to the right; then fasten it by inserting the two pins (Fig.13.B.1) in the provided holes, until the engagement click is heard.
2. Slightly push the safety lever (Fig.13.C) and lift the side discharge guard (Fig.13.D).
3. Insert the side discharge chute (Fig.13.E).
4. Close the side discharge guard (Fig.13.D) so as to lock the side discharge chute (Fig.13.E).

To remove the side discharge chute:

5. Slightly push the safety lever (Fig.13.C) and lift the side discharge guard (Fig.13.D).
6. Release the side discharge chute (Fig.13.E).

### 6.1.3 Handle adjustment (Fig.14/15)

 Do this when the cutting means is stationary.

## 6.2 SAFETY CHECKS

 Always carry out the safety checks before use.

### 6.2.1 Safety check before every use

- Check the integrity and the correct mounting of all components of the machine;
- make sure that all fastening devices are correctly tightened;
- keep all surfaces of the machine clean and dry.

### 6.2.2 Machine operating test

Action	Result
<ol style="list-style-type: none"><li>1. Start the machine and engage the cutting means (par.6.3).</li><li>2. Release the operator presence lever (Fig.21 A).</li></ol>	<ol style="list-style-type: none"><li>1. The cutting means should move.</li><li>2. The lever should return automatically and rapidly to the neutral position, the engine must switch off and the cutting means must stop within a few seconds.</li></ol>
<ol style="list-style-type: none"><li>1. Start the machine (par. 6.3) and operate the drive lever (par. 5.2.3).</li><li>2. Disengage the drive lever.</li></ol>	<ol style="list-style-type: none"><li>1. The wheels should move the machine forward.</li><li>2. The wheels should stop and the machine stops moving forward.</li></ol>
Test driving	No abnormal vibrations. No abnormal sound.

 If any of the results fail to match the indications provided in the tables, do not use the machine! Contact an Authorised Service Centre to have it checked and repaired if necessary.

## 6.3 START-UP

**NOTE** Start the machine on a flat surface without obstacles or high grass.

1. Open the hatch for accessing the battery compartment (Fig.16.A).
2. Fit the batteries correctly in their compartments (Fig. 7.2.3.A) pressing down until the end and until you hear it clicks firmly into position, ensuring thus the electrical contact.
3. Insert the safety key until the end (Fig.17.A). If required, turn the key to "ON" position.
4. Completely close the hatch again.
5. For models that require using a power button for starting, use the power button (fig. 18.A). The LED stays on for 15 seconds.
6. Engage the cutting means by first pressing the safety button (Fig.19.A) and then pressing the operator presence lever (Fig.19.B).
7. To engage the traction, press the lever behind the handle (Fig.19.C).

## 6.4 OPERATION

**IMPORTANT** When working, always keep a safe distance from the cutting means, given by the length of the handle.

The battery power reserve (and therefore the lawn surface to be mown before recharging) depends on many factors, described in (par. 7.2.1).

During use, the charge status of the batteries is displayed (remaining charge percentage) (Fig.8.E).

**IMPORTANT** If the motor stops because it is overheated while mowing, you must wait approximately 5 minutes before restarting it.

### 6.4.1 Grass cutting

1. Start moving forward and mowing the grass area.
2. Adjust speed and cutting height (para 5.3) in relation to lawn conditions (grass height, density and humidity) and the amount of grass to be cut.

**For traction models (par. 5.2.3):** It is recommended to avoid mowing on slopes with a degree higher than 15°.

3. The appearance of the lawn will improve if you alternate cutting in both directions at the same height (Fig.20).

**For side discharge:** it is recommended to follow a path so as to avoid discharging the cut grass from the part of the lawn that is yet to be mown.

**For mulching or rear grass discharge:**

- Always avoid removing a large quantity of grass. Never cut more than one third of the total grass height per single pass (Fig.20).
- Keep the chassis clean (par. 7.3.1).

### 6.4.2 Grass catcher emptying

**For grass catcher with contents indicator device:**



that the grass catcher is full and must be emptied.

To remove and empty the grass catcher:

1. Wait until the cutting means stops;
2. Remove the grass catcher (Fig.25.A).

## 6.5 STOPPING THE MACHINE

To stop the machine:

1. Release the operator presence lever (Fig.21 A).

For models that require using a power button for starting, use the power button (fig. 18.A).

3. Wait until the cutting means stops.

**!** After stopping the machine, it will take a few seconds for the cutting means to stop.

**IMPORTANT** Always stop the machine.

- When moving between work areas.
- When driving on grass free surfaces.
- Every time it is necessary to overcome an obstacle.
- Before adjusting the cutting height.
- Any time the grass catcher is removed or refitted.
- Any time the side discharge chute (if available) is removed or refitted.

## 6.6 AFTER OPERATION

1. Clean (para. 7.3).
2. If necessary, replace damaged components and tighten any slack screws and bolts.

**IMPORTANT** Remove the safety key whenever the machine is unused or left unattended.

## 7. MAINTENANCE

### 7.1 GENERAL INFORMATION

**!** The safety regulations to follow are described in chap. 2. Strictly comply with these instructions to avoid serious risks or dangers.

**!** Before commencing any inspections, cleaning or maintenance/adjustments on the machine:

- Stop the machine.
- Remove the safety key, (never leave the key inserted or within the reach of children or unauthorised persons).
- Make sure that all moving parts have come to a complete stop.
- Allow the motor to cool before storing in an enclosed space.
- Read the relevant instructions.
- Use suitable clothing, protective gloves and goggles.

- The frequency and types of maintenance are summarised in the "Maintenance Table". The table will help you maintain your machine's safety and performance. It summarises the main interventions to be made and the frequency applicable to each of them. Carry out the relevant task as soon as it is scheduled to be performed.
- The use of non-genuine and/or incorrectly assembled spare parts and attachments could adversely affect machine operation and safety. The manufacturer shall decline all liability in the event of injuries or damages caused by such parts.
- Genuine spare parts are supplied by Authorised Assistance Centres and Dealers.

**IMPORTANT** Any maintenance and adjustment operations not described in this manual must be carried out by your Authorised Service Centre.

### 7.2 BATTERY

#### 7.2.1 Battery power reserve

Battery power reserve (and therefore the lawn surface that can be mown before recharging is required) mainly depends on:

- a. Environmental factors that cause higher energy requirements:



- Mowing dense, high and/or wet grass.
- b. Machine cutting width; wider settings involve higher energy consumption.
- c. Operator behaviour that should be avoided:
  - Switching the machine on and off frequently whilst working.
  - Setting a cutting height that is too low for the lawn conditions.
  - Working at a speed that is too high in relation to the amount of grass to be removed.

**NOTE** *During use, the battery is protected against total drainage with a protective device that switches off the machine and prevents its operation.*

To optimise battery power reserve it is always recommended to:

- Cut the grass when the lawn is dry.
- Cut the grass frequently so that it doesn't grow too tall.
- Set a higher cutting height when the grass is very tall, then set a lower height and cut the lawn again.
- Do not use the machine in "mulching" mode with very high grass.
- Use of the "ECO" mode (par. 5.2.4).

If the need arises to use the machine for sessions which exceed the capability of a standard battery, it is possible to:

- Purchase a second standard battery to immediately replace the discharged battery, without compromising the continuity of operations.
- Purchase a battery with an extended power reserve compared to the standard version (par. 13.2).

### 7.2.2 Battery removal and recharging

1. Open the battery compartment access hatch and remove the safety key.
2. Press the button on the battery (Fig.22.A) and remove the battery (Fig.22.B).
3. Insert the battery (Fig.23.B) in its housing in the battery charger (Fig.23.C).
4. Connect the battery charger to a power socket with the voltage indicated on the rating plate.
5. Fully charge the battery according to the instructions in the battery/battery charger booklet.

**NOTE** *The battery is equipped with a protective device that inhibits recharging if the environmental temperature is not between 0 and +45 °C.*

**NOTE** The battery can be recharged at any time, even partially, with no risk of damaging it.

### 7.2.3 Refitting the battery on the machine

When recharging is completed:

1. Remove the battery from the housing in the battery charger (do not keep recharging when recharging is completed).
2. Disconnect the battery charger from the mains power supply.
3. Open the battery housing hatch (Fig.24.A), insert the battery (Fig.24.B) into its housing pressing down until you hear it click firmly into position, ensuring thus the electrical contact.

Completely close the hatch again.

## 7.3 CLEANING

Clean thoroughly following the instructions below every time it is used.

### 7.3.1 Cleaning the machine

- Always make sure the air intakes are free of debris.
- Do not spray water onto the motor and electrical components, prevent them from getting wet (Fig.26).
- Do not use aggressive liquids to clean the chassis.
- To reduce the risk of fire, keep the engine free of grass, leaves residues or excessive grease.
- Always keep the levers, display and buttons free of debris.

### 7.3.2 Cleaning the cutting means assembly

Remove grass debris and mud accumulated inside the chassis.

- **For side discharge:** remove the discharge chute (if mounted - par. 6.1.2d).

### 7.3.3 Cleaning the grass catcher (Fig.27.A/B)

## 7.4 NUTS AND BOLTS

Keep all nuts, bolts and screws tight to be sure the equipment is in a safe working condition.

## 7.5 CLEANING THE AIR FILTER

- The filter element must always be kept perfectly clean.
- Proceed as follows:

1. Clean around the air filter grid.
  2. Unscrew the screw (Fig.28.B) to remove the grid (Fig.28.A).
  3. Remove the filter element (Fig.29.A).
  4. Blow the filter of wash it with water (Fig.29.A) to remove the dust and residues.
  5. Refit the filter element (Fig.29.A) in its housing, refit the grid and tighten the screw (Fig.28.A) and (Fig. 28.B).
- Wear heavy duty gloves.
  - Hold the machine in the points offering a safe grip, taking into account the weight and its division.
  - Use an appropriate number of people for the weight of the machine and the characteristics of the vehicle or the place where it must be placed or collected.

## 8. OCCASIONAL MAINTENANCE

 **Before commencing any inspections, cleaning or maintenance/adjustments on the machine:**

- Stop the machine.
- Remove the safety key, (never leave the key inserted or within the reach of children or unauthorised persons).
- Make sure that all moving parts have come to a complete stop.
- Allow the motor to cool before storing in an enclosed space.
- Read the relevant instructions.
- Use suitable clothing, protective gloves and goggles.

## 8.1 CUTTING MEANS

An improperly sharpened cutting means pulls at the grass and causes the lawn to turn yellow.

 **Do not touch the cutting means until the key has been removed and the cutting means is completely stationary.**

 **All operations on the cutting means (disassembly, sharpening, balancing, repairing, reassembly and/or replacing) are complex jobs that require special skills as well as special tools; For safety reasons, these jobs are best carried out at a Authorised Service Centre.**

 **Make sure damaged, misshapen or worn cutting means are replaced, together with the securing screws, to preserve balance.**

**IMPORTANT** Always use original cutting means bearing the code indicated in the "Technical Data" table.

Given product evolution, the cutting means listed in the "Technical Data" table may be replaced in time with others having similar interchangeable and operating safety features.

## 9. STORAGE

### 9.1 STORING THE MACHINE

When the machine is to be stored away:

1. Wait for the engine to cool.
2. Remove the safety key.
3. Clean (par. 7.3).
4. Check the integrity of the machine.
5. Store the machine (Fig.34):
  - In a dry place.
  - Protected from inclement weather.
  - In a place where children cannot get to it.

- Making sure that keys or tools used for maintenance are removed.

### 9.2 STORING THE BATTERY

The battery must be kept in a cool, shaded place without humidity.

**NOTE** In case of prolonged periods of inactivity, recharge the battery every two months.

## 10. HANDLING AND TRANSPORTATION

Whenever the machine is to be handled, raised, transported or tilted you must:

- Stop the machine (par.6.5) until the moving parts come to a complete halt.
- Wear heavy duty gloves.
- Hold the machine in the points offering a safe grip, taking into account the weight and its division.
- Use an appropriate number of people for the weight of the machine and the characteristics of the vehicle or the place where it must be placed or collected.
- Make sure that machine movements do not cause damage or injuries.

When transporting the machine on a vehicle or trailer, always:

- Use an access ramp of suitable strength, width and length.
- Load the machine with the motor switched off and pushed by an adequate number of people.
- Lower the cutting means assembly.
- Position it so that it cannot cause a hazard for anybody.
- Fasten firmly to the means of transport using ropes or chains to prevent it from tipping over.

## 11. MAINTENANCE TABLE

Intervention	Frequency	Notes
<b>MACHINE</b>		
Check all fasteners ; Safety checks/check controls; Check the rear/lateral discharge guards; Check the grass catcher bag and lateral discharge chute; Check the cutting means.	Before use	par. 6.2
General cleaning and inspection; Checking for any damage to the machine. If necessary, contact the authorised service centre.	After each use	par. 7.3
Replacing the cutting means	-	par. 81 ***
Check the battery charge status	Before each use	*
Recharge the battery	After each use	par. 7.2.2 *
Cleaning the air filter	Once a month	par. 7.5

\* Refer to the battery/battery charger manual.

\*\* The operation must be carried out by your Dealer or a specialised Authorised Service Centre

\*\*\* Operation to be performed at the first signs of any malfunction



## 12. PROBLEM IDENTIFICATION

### 12.1 FOR MACHINES WITH ELECTRONIC CONTROL

If problems persist after having performed the above operations, contact your dealer.		
PROBLEM	PROBABLE CAUSE	SOLUTION
1. After pressing the starter button, the LED does not come ON.	Safety key is not inserted or is inserted incorrectly.	Insert the key (par. 6.3).
	Safety key in "OFF" position.	Turn the safety key to "ON" position (par. 6.3).
	Battery is not inserted or is inserted incorrectly.	Open the hatch and check that the battery is fitted in its housing correctly (par. 7.2.3).
	Low battery.	Check the battery status and recharge if necessary (par. 7.2.2).
	Incorrect battery combination.	Check if the battery combination is correct, following the instructions supplied in the "Technical data" table.
2. After pressing the starter button, the LED does not come ON and the machine sets off a sound signal.	Internal motor anomaly.	Remove the safety key and contact the Authorised Service Centre for checks, replacements or repairs.
3. The motor shuts down whilst working.	Battery is not inserted correctly.	Open the hatch and check that the battery is fitted in its housing correctly (par. 7.2.3).
	Low battery.	Check the battery status and recharge if necessary (par. 7.2.2).
4. The danger LED lights up (Fig. 30.A) and the machine emits an acoustic signal.	Cutting means blocked.	Turn the machine off, remove the safety key and wear work gloves. Check and eventually remove any obstructions in the machine lower side (par. 7.3.2) that prevent rotation of the cutting means. If the problem continues, contact the Authorised Service Centre for checks, replacements or repairs (par. 8.1).
	Machine fault	Remove the safety key and contact the Authorised Service Centre for checks, replacements or repairs.
5. The danger LED lights up (Fig.30.A).	The thermal protection has tripped due to overheating of the machine.	Wait for at least 5 minutes and restart the machine.
6. Mowing is difficult.	The cutting means is not in good state.	Contact the Authorised Service Centre for the sharpening or replacement of the cutting means.
7. Excessive noise and/or vibration is experienced whilst working.	Cutting means fittings are loose or the cutting means is damaged.	Immediately turn off the motor and remove the safety key. Contact the Authorised Service Centre for checks, replacements or repairs (par. 8.1).
8. Battery power reserve is low.	Severe working conditions requiring greater current absorption.	Optimise operations (par. 7.2.1).
	Battery is insufficient for operating requirements.	Use a second battery or extended battery (par. 13.2).

9. The battery charger is not charging the battery.	Battery is not correctly inserted in the battery charger.	Check it is correctly inserted (par. 7.2.3).
	Unsuitable environmental conditions.	Recharge the battery in places with suitable temperatures (see battery/battery charger instruction manual).
	Dirty contacts.	Clean the contacts.
	The battery charger is not energised.	Check it is plugged in and the power socket is energised.
	Faulty battery charger.	Replace with an original spare part.
		If the problem persists, refer to the battery/battery charger manual.

## 12.2 FOR MACHINES WITHOUT ELECTRONIC CONTROL

If problems persist after having performed the above operations, contact your dealer.		
PROBLEM	PROBABLE CAUSE	SOLUTION
1. The engine does not start when using the switch	Safety key is not inserted or is inserted incorrectly.	Insert the key (par. 6.3).
	Safety key in "OFF" position.	Turn the safety key to "ON" position (par. 6.3).
	Battery is not inserted or is inserted incorrectly.	Open the hatch and check that the battery is fitted in its housing correctly (par. 7.2.3).
	Low battery.	Check the battery status and recharge if necessary (par. 7.2.2).
	Incorrect battery combination.	Check if the battery combination is correct, following the instructions supplied in the "Technical data" table.
2. The engine stops and the machine emits an acoustic signal.	Battery is not inserted correctly.	Open the hatch and check that the battery is fitted in its housing correctly (par. 7.2.3).
	Low battery.	Check the battery status and recharge if necessary (par. 7.2.2).
	The thermal protection has tripped due to overheating of the motor.	Wait for at least 5 minutes and restart the machine.
	Cutting means blocked.	Turn the machine off, remove the safety key and wear work gloves. Check and eventually remove any obstructions in the machine lower side (par. 7.3.2) that prevent rotation of the cutting means. If the problem continues, contact the Authorised Service Centre for checks, replacements or repairs (par. 8.1).
	Machine fault	Remove the safety key and contact the Authorised Service Centre for checks, replacements or repairs.
3. Mowing is difficult.	The cutting means is not in good state.	Contact the Authorised Service Centre for the sharpening or replacement of the cutting means.
4. Excessive noise and/or vibration is experienced whilst working.	Cutting means fittings are loose or the cutting means is damaged.	Immediately turn off the motor and remove the safety key. Contact the Authorised Service Centre for checks, replacements or repairs (par. 8.1).

5. Battery power reserve is low.	Severe working conditions requiring greater current absorption.	Optimise operations (par. 7.2.1).
	Battery is insufficient for operating requirements.	Use a second battery or extended battery (par. 13.2).
6. The battery charger is not charging the battery.	Battery is not correctly inserted in the battery charger.	Check it is correctly inserted (par. 7.2.3).
	Unsuitable environmental conditions.	Recharge the battery in places with suitable temperatures (see battery/battery charger instruction manual).
	Dirty contacts.	Clean the contacts.
	The battery charger is not energised.	Check it is plugged in and the power socket is energised.
	Faulty battery charger.	Replace with an original spare part.
		If the problem persists, refer to the battery/ battery charger manual.

### 13. ATTACHMENTS ON REQUEST

#### 13.1 "MULCHING" KIT

Finely chops the cut grass and leaves it on the lawn, instead of collecting it in the grass catcher (for machines equipped with it) (Fig.31).

#### 13.2 BATTERIES

Different capacity batteries are available to suit specific operating requirements (Fig. 32). The list of approved batteries for this machine can be found in the "Technical Data" table.

#### 13.3 BATTERY CHARGER

Device used to recharge the battery (Fig.33).

**DICHIARAZIONE CE DI CONFORMITÀ** (Istruzioni Originali)  
(Direttiva Macchine 2006/42/CE, Allegato II, parte A)

1. La Società: ST. S.p.A. – Via del Lavoro, 6 – 31033 Castelfranco Veneto (TV) – Italy

2. Dichiaro sotto la propria responsabilità, che la macchina:

Tosaerba con conducente a piedi (taglio erba)

a) Tipo / Modello Base:	CP1 430 •• Li •48
c) Numero di Serie:	24A••WBH000001 ÷ 99L••WBH999999
d) Motore:	a batteria

3. È conforme alle specifiche delle direttive:

- MD: 2006/42/EC
- OND: 2000/14/EC, ANNEX VI - 2005/88/EC
  - e) Notified body N. 0197 – TÜV Rheinland LGA Products GmbH  
Tillystrasse 2, 90431 Nürnberg – Germany
- EMCD: 2014/30/EU
- RoHS II: 2011/65/EU - 2015/863/EU

4. Riferimento alle norme armonizzate:

EN 60335-1:2012 + A11:2014 + A13:2017 + A14 + A2 + A15:2021  
EN 60335-2-77:2010  
EN IEC 55014-1:2021  
EN IEC 55014-2:2021  
EN ISO 12100:2010  
EN IEC 63000:2018

g) Livello di potenza sonora misurato:	90,24 dB(A)
h) Livello di potenza sonora garantito:	92 dB(A)
i) Ampiezza di taglio:	41 cm

n) Persona autorizzata a costituire il Fascicolo Tecnico:	ST. S.p.A. Via del Lavoro, 6 31033 Castelfranco Veneto (TV) - Italia
---	--

o) Castelfranco Veneto, 22/11/2024

CEO Stiga Group  
Sean Robinson



## UK DECLARATION OF CONFORMITY

(Supply of Machinery (Safety) Regulations 2008, S.I. 2008 No. 1597, Annex II, part A)

1. The company: ST. S.p.A. – Via del Lavoro, 6 – 31033 Castelfranco Veneto (TV) – Italy

2. Hereby declares under its own responsibility that the machine (function):

Pedestrian-controlled lawn mower (grass cutting)

a) Homologation type:	CP1 430 •• Li •48
c) Serial number:	24A••WBH000001 ÷ 99L••WBH999999
d) Engine:	battery-operated

3. Conforms to UK Regulations:

- S.I. 2008/1597 - Supply of Machinery (Safety) Regulations 2008
- S.I. 2001/1701 - Schedule 9 - Noise Emission in the Environment by Equipment for use Outdoors Regulations 2001
  - e) Notified body: N. 0197 – TÜV Rheinland LGA Products GmbH  
Tillystrasse 2, 90431 Nürnberg – Germany
- S.I. 2016/1091 - Electromagnetic Compatibility Regulations 2016
- S.I. 2012/3032 - The Restriction of the Use of Certain Hazardous Substances in Electrical and Electronic Equipment Regulations 2012

4. Reference to harmonised standards:

EN 60335-1:2012 + A11:2014 + A13:2017 + A14 + A2 + A15:2021  
EN 60335-2-77:2010  
EN IEC 55014-1:2021  
EN IEC 55014-2:2021  
EN ISO 12100:2010  
EN IEC 63000:2018

g) Measured sound power level:	90,24 dB(A)
h) Guaranteed sound power level:	92 dB(A)
i) Cutting width:	41 cm

n) Person authorised to compile the technical file:	ST. S.p.A. Via del Lavoro, 6 31033 Castelfranco Veneto (TV) - Italia
---	--

o) Castelfranco Veneto, 22/11/2024

CEO Stiga Group  
Sean Robinson

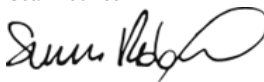

UK Importer: STIGA LTD  
Unit 8, Bluewater Estate Plympton,  
Devon, PL7 4JH, England



**DICHIARAZIONE CE DI CONFORMITÀ** (Istruzioni Originali)  
(Direttiva Macchine 2006/42/CE, Allegato II, parte A)

1. La Società: ST. S.p.A. – Via del Lavoro, 6 – 31033 Castelfranco Veneto (TV) – Italy

2. Dichiaro sotto la propria responsabilità, che la macchina:

Tosaerba con conducente a piedi (taglio erba)

a) Tipo / Modello Base:	CP1 480 •• Li •48
c) Numero di Serie:	24A••WBH000001 ÷ 99L••WBH999999
d) Motore:	a batteria

3. È conforme alle specifiche delle direttive:

- MD: 2006/42/EC
- OND: 2000/14/EC, ANNEX VI - 2005/88/EC
  - e) Notified body N. 0197 – TÜV Rheinland LGA Products GmbH  
Tillystrasse 2, 90431 Nürnberg – Germany
- EMCD: 2014/30/EU
- RoHS II: 2011/65/EU - 2015/863/EU

4. Riferimento alle norme armonizzate:

EN 60335-1:2012 + A11:2014 + A13:2017 + A14 + A2 + A15:2021  
EN 60335-2-77:2010  
EN IEC 55014-1:2021  
EN IEC 55014-2:2021  
EN ISO 12100:2010  
EN IEC 63000:2018

g) Livello di potenza sonora misurato:	94,36 dB(A)
h) Livello di potenza sonora garantito:	95 dB(A)
i) Ampiezza di taglio:	46 cm

n) Persona autorizzata a costituire il Fascicolo Tecnico:	ST. S.p.A. Via del Lavoro, 6 31033 Castelfranco Veneto (TV) - Italia
--	--

o) Castelfranco Veneto, 22/11/2024

CEO Stiga Group

Sean Robinson

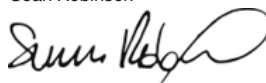

## UK DECLARATION OF CONFORMITY

(Supply of Machinery (Safety) Regulations 2008, S.I. 2008 No. 1597, Annex II, part A)

1. The company: ST. S.p.A. – Via del Lavoro, 6 – 31033 Castelfranco Veneto (TV) – Italy

2. Hereby declares under its own responsibility that the machine (function):

Pedestrian-controlled lawn mower (grass cutting)

a) Homologation type:	CP1 480 •• Li •48
c) Serial number:	24A••WBH000001 ÷ 99L••WBH999999
d) Engine:	battery-operated

3. Conforms to UK Regulations:

- S.I. 2008/1597 - Supply of Machinery (Safety) Regulations 2008
- S.I. 2001/1701 - Schedule 9 - Noise Emission in the Environment by Equipment for use Outdoors Regulations 2001
  - e) Notified body: N. 0197 – TÜV Rheinland LGA Products GmbH  
Tillystrasse 2, 90431 Nürnberg – Germany
- S.I. 2016/1091 - Electromagnetic Compatibility Regulations 2016
- S.I. 2012/3032 - The Restriction of the Use of Certain Hazardous Substances in Electrical and Electronic Equipment Regulations 2012

4. Reference to harmonised standards:

EN 60335-1:2012 + A11:2014 + A13:2017 + A14 + A2 + A15:2021  
EN 60335-2-77:2010  
EN IEC 55014-1:2021  
EN IEC 55014-2:2021  
EN ISO 12100:2010  
EN IEC 63000:2018

g) Measured sound power level: 94,36 dB(A)  
h) Guaranteed sound power level: 95 dB(A)  
i) Cutting width: 46 cm

n) Person authorised to compile the technical file: ST. S.p.A.  
Via del Lavoro, 6  
31033 Castelfranco Veneto (TV) - Italia

o) Castelfranco Veneto, 22/11/2024

CEO Stiga Group  
Sean Robinson

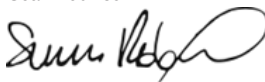

UK Importer: STIGA LTD  
Unit 8, Bluewater Estate Plympton,  
Devon, PL7 4JH, England

**UK  
CA**

**DICHIARAZIONE CE DI CONFORMITÀ** (Istruzioni Originali)  
(Direttiva Macchine 2006/42/CE, Allegato II, parte A)

1. La Società: ST. S.p.A. – Via del Lavoro, 6 – 31033 Castelfranco Veneto (TV) – Italy

2. Dichiaro sotto la propria responsabilità, che la macchina:

Tosaerba con conducente a piedi (taglio erba)

a) Tipo / Modello Base:	CP1 530 •• Li D48
c) Numero di Serie:	22A••WBH000001 ÷ 99L••WBH999999
d) Motore::	a batteria

3. È conforme alle specifiche delle direttive:

- MD: 2006/42/EC
- OND: 2000/14/EC, ANNEX VI - 2005/88/EC
  - e) Notified body N. 0197 – TÜV Rheinland LGA Products GmbH  
Tillystrasse 2, 90431 Nürnberg – Germany
- EMCD: 2014/30/EU
- RoHS II: 2011/65/EU - 2015/863/EU

4. Riferimento alle norme armonizzate:

EN 60335-1:2012 + A11:2014 + A13:2017 + A14 + A2 + A15:2021  
EN 60335-2-77:2010  
EN IEC 55014-1:2021  
EN IEC 55014-2:2021  
EN ISO 12100:2010  
EN IEC 63000:2018

g) Livello di potenza sonora misurato:	95,6 dB(A)
h) Livello di potenza sonora garantito:	98 dB(A)
i) Ampiezza di taglio:	51 cm

n) Persona autorizzata a costituire il Fascicolo Tecnico:	ST. S.p.A. Via del Lavoro, 6 31033 Castelfranco Veneto (TV) - Italia
--	--

o) Castelfranco Veneto, 22/11/2024

CEO Stiga Group  
Sean Robinson

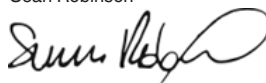



## UK DECLARATION OF CONFORMITY

(Supply of Machinery (Safety) Regulations 2008, S.I. 2008 No. 1597, Annex II, part A)

1. The company: ST. S.p.A. – Via del Lavoro, 6 – 31033 Castelfranco Veneto (TV) – Italy
2. Hereby declares under its own responsibility that the machine (function):

Pedestrian-controlled lawn mower (grass cutting)

- |                       |                                 |
|-----------------------|---------------------------------|
| a) Homologation type: | CP1 530 •• Li D48               |
| c) Serial number:     | 22A••WBH000001 ÷ 99L••WBH999999 |
| d) Engine:            | battery-operated                |

### 3. Conforms to UK Regulations:

- S.I. 2008/1597 - Supply of Machinery (Safety) Regulations 2008
- S.I. 2001/1701 - Schedule 9 - Noise Emission in the Environment by Equipment for use Outdoors Regulations 2001
- e) Notified body: N. 0197 – TÜV Rheinland LGA Products GmbH  
Tillystrasse 2, 90431 Nürnberg – Germany
- S.I. 2016/1091 - Electromagnetic Compatibility Regulations 2016
- S.I. 2012/3032 - The Restriction of the Use of Certain Hazardous Substances in Electrical and Electronic Equipment Regulations 2012

### 4. Reference to harmonised standards:

EN 60335-1:2012 + A11:2014 + A13:2017 + A14 + A2 + A15:2021  
EN 60335-2-77:2010  
EN IEC 55014-1:2021  
EN IEC 55014-2:2021  
EN ISO 12100:2010  
EN IEC 63000:2018

- |                                  |            |
|----------------------------------|------------|
| g) Measured sound power level:   | 95,6 dB(A) |
| h) Guaranteed sound power level: | 98 dB(A)   |
| i) Cutting width:                | 51 cm      |
- n) Person authorised to compile the technical file: ST. S.p.A.  
Via del Lavoro, 6  
31033 Castelfranco Veneto (TV) - Italia
- o) Castelfranco Veneto, 22/11/2024

CEO Stiga Group  
Sean Robinson



UK Importer: STIGA LTD  
Unit 8, Bluewater Estate Plympton,  
Devon, PL7 4JH, England



FR (Traduction de la notice originale)	EN (Translation of the original instruction)	DE (Übersetzung der Originalbetriebsanleitung)
<p>Déclaration CE de Conformité (Directive Machines 2006/42/CE, Annexe II, partie A) 1. La Société</p> <p>2. Déclare sous sa propre responsabilité que la machine : Tondeuse à gazon à conducteur a pied / coupe du gazon</p> <p>a) Type / Modèle de Base c) Série d) Moteur: à batterie</p> <p>3. Est conforme aux prescriptions des directives : e) Organisme de certification : <i>Non applicable</i> f. Renvoi aux Normes harmonisées g) Niveau de puissance sonore mesuré h) Niveau de puissance sonore garanti i) Largeur de coupe n) Personne habilitée à établir le Dossier Technique : o) Lieu et Date</p>	<p>EC Declaration of Conformity (Machine Directive 2006/42/EC, Annex II, part A) 1. The Company</p> <p>2. Herby declares under its own responsibility that the machine: Pedestrian controlled lawn mower / Grass cutting</p> <p>a) Type / Base Model c) Serial number d) Motor: battery-operated</p> <p>3. Conforms to directive specifications: e) Certifying body: <i>Not applicable</i> f. Reference to harmonised Standards g) Sound power level measured h) Sound power level guaranteed i) Range of cut n) Person authorised to create the Technical Folder: o) Place and Date</p>	<p>EG-Konformitätserklärung (Maschinenrichtlinie 2006/42/EG, Anhang II, Teil A) 1. Die Gesellschaft</p> <p>2. Erklärt auf eigene Verantwortung, dass die Maschine: Handgeführter Rasenmäher / Rasenschnitt</p> <p>a) Typ / Basismodell c) Seriennummer d) Motor: Batterie</p> <p>3. Den Anforderungen der folgenden Richtlinien entspricht: e) Zertifizierungsstelle: <i>unzutreffend</i> f. Bezugnahme auf die harmonisierten Normen g) Gemessener Schalleistungspegel h) Garantierter Schalleistungspegel i) Schnittbreite n) Zur Verfässung der technischen Unterlagen befugte Person: o) Ort und Datum</p>
<p>NL (Vertaling van de oorspronkelijke gebruiksaanwijzing)</p> <p>EG-verklaring van overeenstemming (Richtlijn Machines 2006/42/CE, Bijlage II, deel A) 1. Het bedrijf</p> <p>2. Verklaart onder zijn eigen verantwoordelijkheid dat de machine: Lopend bediende grasmaaier / grasmaaier</p> <p>a) Type / Basismodel c) Seriennummer d) Motor : accu</p> <p>3. Voldoet aan de specificaties van de richtlijnen: e) Certificatie-instituut: <i>Niet toepasbaar</i> f. Verwijzing naar de Geharmoniseerde normen g) Gemeten niveau van geluidsvormogen h) Gegarandeerd niveau van geluidsvormogen i) Snijbreedte n) Bevoegd persoon voor het opstellen van het Technisch Dossier o) Plaats en Datum</p>	<p>ES (Traducción del Manual Original)</p> <p>Declaración de Conformidad CE (Directiva Máquinas 2006/42/CE, Anexo II, parte A) 1. La Empresa</p> <p>2. Declara bajo su propia responsabilidad que la máquina: Cortadora de pasto con operador de pie / corte hierba</p> <p>a) Tipo / Modelo Base c) Matricula d) Motor: batería</p> <p>3. Cuple con las especificaciones de las directivas: e) Ente certificador: <i>No aplica</i> f. Referencia a las Normas armonizadas g) Nivel de potencia sonora medido h) Nivel de potencia sonora garantizado i) Amplitud de corte n) Persona autorizada a realizar el Manual Técnico: o) Lugar y Fecha</p>	<p>PT (Tradução do manual original)</p> <p>Declaração CE de Conformidade (Diretiva de Máquinas 2006/42/CE, Anexo II, parte A) 1. A Empresa</p> <p>2. Declara sob a própria responsabilidade que a máquina: Corta-relvas para operador apeado / corte da relva</p> <p>a) Tipo / Modelo Base c) Matricula d) Motor: Bateria</p> <p>3. E conforme às especificações das diretivas: e) Órgão certificador: <i>Não aplicável</i> f. Referência às Normas harmonizadas g) Nível medido de potência sonora h) Nível garantido de potência sonora i) Amplitude de corte n) Pessoa autorizada a elaborar o Caderno Técnico o) Local e Data</p>
<p>EL (Μετάφραση του πρωτοτύπου των οδηγιών χρήσης)</p> <p>EK-Δήλωση συμμόρφωσης (Οδηγία Μηχανών 2006/42/CE, Παράρτημα II, μέρος Α) 1. Η Εταιρεία</p> <p>2. Δηλώνει υπεύθυνα ότι η μηχανή: Χλοοκοπτική μηχανή με όρθιο χειριστή / κοπή της χλόης</p> <p>a) Τύπος / Βασικό Μοντέλο c) Αριθμός μητρώου d) Κινητήρας: μπαταρία</p> <p>3. Συμμορφώνεται με τις προδιαγραφές της οδηγίας: e) Οργανισμός πιστοποίησης: <i>Δεν εφαρμόζεται</i> f. Αναφορά στους Κανονισμούς αρμόδιους g) Στάθμη μέτρησης ακουστικής ισχύος h) Στάθμη εγγυημένης ακουστικής ισχύος i) Έυρος κοπής n) Εξουσιοδοτημένο άτομο για την κατάρτιση του Τεχνικού Φυλλοδίου. o) Τόπος και Χρόνος</p>	<p>TR (Original Talimatların Tercümesi)</p> <p>AT Uygunluk Beyanı (2006/42/CE Makine Direktifi, Ek II, bölüm A) 1. Şirket</p> <p>2. Şahsi sorumluluğu altında aşağıdaki makinenin: Ayak kumandalı çim biçme makinesi / çim kesimi</p> <p>a) Tip / Standart model c) Sicil numarasi d) Motor : batarya</p> <p>3. Aşağıdaki direktiflerin özelliklerine uygun olduğunu beyan etmektedir: e) Sertifikalandırım kurum: <i>Uygunlanamaz</i> f. Harmonize standartlara atıf g) Ölçülen ses gücü seviyesi h) Garantli edilen ses gücü seviyesi i) Kesim genişliği n) Teknik Dosyayı oluştururmayla yetkili kişi: o) Yer ve Tarih</p>	<p>МК (Превод на оригиналните упътства)</p> <p>Декларация за усовпаденост со ЕУ (Директива за машини 2006/42/CE, Аннекс II, дел А) 1. Компанијата</p> <p>2. изјавува со целосна лична одговорност дека следната машина: Тревокосячка со оператор на ноге / косяче трава</p> <p>a) Тип / основен модел b) етикета f) мотор: акумулатор</p> <p>3. Усовпаденост со спецификациите според директивите: d) тело за сертификација: <i>Не се применува</i> f) тест CE за типот: <i>Не се применува</i> g. Референци за усогласени нормативи e) Акустички притисок n) Ниво на гарантирана звучна моќност o) овластен лице за составување на Техничката брошура o) место и датум</p>
<p>NO (Oversettelse av original bruksanvisning)</p> <p>EF- Samsvarserklæring (Maskindirektiv 2006/42/EF, Vedlegg II, del A) 1. Firmaet</p> <p>2. Erklærer på eget ansvar at maskinen: Håndført gressklipper/ grassklipping</p> <p>a) Type / Modell c) Serienummer d) Motor: batteri</p> <p>3. Oppfyller kravene i direktivene: e) Sertifiseringsorgan: <i>ikke aktuelt</i> f. Henvisning til harmoniserte standarder g) Målt lydeffektivnivå h) Garantert lydeffektivnivå i) Klippebredde n) Person som har fullmakt til å utferdige teknisk dokumentasjon: o) Sted og dato</p>	<p>SV (Översättning av bruksanvisning i original)</p> <p>EG-försäkran om överensstämmelse (Maskindirektiv 2006/42/EG, bilaga II, de la) 1. Företaget</p> <p>2. Försäkrar på eget ansvar att maskinen: Förarlett grasklippare / grasklippning</p> <p>a) Typ / Basmodell c) Serienummer d) Motor: batteri</p> <p>3. Överensstämmer med föreskrifterna i direktivet e) Intygsorgan. Anmält organ: <i>Inte tillämpligt</i> f. Referens till harmoniserade standarder g) Uppmått ljudeffektivnivå h) Garanterad ljudeffektivnivå i) Skärbredd n) Örtorättad person för upprättandet av den tekniska dokumentationen: o) Ort och datum</p>	<p>DA (Oversættelse af den originale brugsanvisning)</p> <p>EF-øverenstemmelseserklæring (Maskindirektiv 2006/42/EF, bilag II, del A) 1. Firmaet</p> <p>2. Erklærer på eget ansvar, at maskinen: Plæneklipper betjent af gående personer / klipping af græsset</p> <p>a) Type / Model c) Serienummer d) Motor: batteri</p> <p>3. Er i overensstemmelse med specifikationerne ifølge direktivene: e) Certificeringsorgan: <i>ikke anvendt</i> f. Henvisning til harmoniserede standarder g) Målt lydeffektivniveau h) Garanteret lydeffektivniveau i) Klippebredde n) Person, der har bemyndigelse til at udarbejde det tekniske dossier: o) Sted og dato</p>
<p>HU (Eredeti használati utasítás fordítása)</p> <p>EK-megfelelőségi nyilatkozata (2006/42/EK gépirányelv, II. melléklet "A" rész) 1. A vállalat</p> <p>2. Felelősségének teljes tudatában kijelenti, hogy az alábbi gép: Gyepnyírógépes fűnyírógép / fűnyírás</p> <p>a) Típus / Alaptípus c) Gyártási szám d) Motor: akkumulátor</p> <p>3. Megfelel az alábbi irányelvek előírásainak: e) Tanúsító szerv: <i>Nem alkalmazható</i> f. Hivatkozás a harmonizált szabványokra g) Mért zajteljesítmény szint h) Garantált zajteljesítmény szint i) Vágási szélesség n) Műszaki Dosszié szerkesztésére felhatalmazott személy: o) Helye és ideje</p>	<p>RU (Перевод оригинальных инструкций)</p> <p>Декларация соответствия нормам ЕС (Директива о машинном оборудовании 2006/42/EC, Приложение II, часть А) 1. Предприятие</p> <p>2. Заявляет под собственную ответственность, что машина: Газонокосилка с пешеходным управлением/стрижка газона</p> <p>a) Тип / Базовая модель c) Паспорт d) Производитель: батарея хранения</p> <p>3. Соответствует требованиям следующих директив: e) Сертифицирующий орган: <i>Неприменяемый</i> f. Ссылки на гармонизированные нормы g) Измеренный уровень звуковой мощности h) Гарантируемый уровень звуковой мощности i) Амплитуда косания n) Лицо, уполномоченное на подготовку технической документации: o) Место и дата</p>	<p>HR (Prijevod originalnih uputa)</p> <p>EK Izjava o sukladnosti (Direktiva 2006/42/EZ o strojevima, dodatak II, dio A) 1. Tvrtka</p> <p>2. pod vlastitom odgovornošću izjavljuje da je stroj: Ručno upravljana kosilica trave/košenje trave</p> <p>a) Vrsta / Osnovni model c) Matični broj d) Motor: baterija</p> <p>3. sukladna s temeljnim zahtjevima direktiva: e) Certificacijsko tijelo: <i>Nije primjenjivo</i> f. Primijenjene su sljedeće harmonizirane norme: g) Izmjerena razina zvučne snage h) Zajamčena razina zvučne snage i) Širina rezanja n) Osoba ovlaštena za pravljenje Tehničke datoteke: o) Mjesto i datum</p>

<p><b>FI</b> (Alkuperäisten ohjeiden käännös)</p> <p>EY-VAATIMUSTENMUKAISUUSVAKUUTUS (Konedirektiivi 2006/42/EY, Liite II, osa A)</p> <ol style="list-style-type: none"> <li>Yritys</li> <li>Vakuitaan omalla vastuullaan, että kone: Kävelleen ohjattava ruohonleikkuri/ruohonleikkuri</li> <li>Typo / Perusmalli</li> <li>Sarjanumero</li> <li>Moottori : akku</li> <li>On yhdenmukainen seuraavien direktiivien asettamien vaatimusten kanssa:       <ol style="list-style-type: none"> <li>Sertifiointityyppi : Ei sovellettavissa</li> <li>Vittaus harmonisointiin standardeihin</li> <li>Mittattu äänitehotaso</li> <li>Taattu äänitehotaso</li> <li>Leikkuleveys</li> <li>Teknisten asiakkaiden laatimiseen valtuutettu henkilö:</li> <li>Paikka ja päivämäärä</li> </ol> </li> </ol>	<p><b>CS</b> (Překlad původního návodu k používání)</p> <p>ES – Prohlášení o shodě (Směrnice o Strojích zařazených 2006/42/ES, Příloha II, část A)</p> <ol style="list-style-type: none"> <li>Společnost</li> <li>Prohlásuje na vlastní odpovědnost, že stroj: Sekačka se stojící obsluhou / sekačka na trávu       <ol style="list-style-type: none"> <li>Typ / Základní model</li> <li>Výrobní číslo</li> <li>Motor: akumulátor</li> </ol> </li> <li>Je ve shodě s nařízeními směrnice:       <ol style="list-style-type: none"> <li>Certifikační orgán: <i>Nije treba poziviti</i></li> <li>Odkazy na Harmonizované normy</li> <li>Naměřená úroveň akustického výkonu</li> <li>Zaručená úroveň akustického výkonu</li> <li>Šířka fezání</li> <li>Osoba ověřovaná pro vytvoření Technického spisu:</li> <li>Místo a Datum</li> </ol> </li> </ol>	<p><b>PL</b> (Tłumaczenie instrukcji oryginalnej)</p> <p>Deklaracja zgodności WE (Dyrektywa maszynowa 2006/42/WE, Załącznik II, część A)</p> <ol style="list-style-type: none"> <li>Spółka</li> <li>Oświadczam na własną odpowiedzialność, że maszyna: Kosiarzka prowadzona przez operatora pieszego / ciecie trawy       <ol style="list-style-type: none"> <li>Typ / Model podstawowy</li> <li>Numer seryjny</li> <li>Silnik: akumulator</li> </ol> </li> <li>Spełnia podstawowe wymogi następujących Dyrektyw:       <ol style="list-style-type: none"> <li>Jednostka certyfikująca: <i>Nie dotyczy</i></li> <li>Odwołanie do Norm zharmonizowanych</li> <li>Zmierzony poziom mocy akustycznej</li> <li>Gwarantowany poziom mocy akustycznej</li> <li>Szerokość ciecia</li> <li>Osoba upoważniona do zredagowania Dokumentacji technicznej:</li> <li>Miejscowość i data</li> </ol> </li> </ol>
<p><b>SL</b> (Prevod izvirnih navodil)</p> <p>ES izjava o skladnosti (Direktiva 2006/42/ES, priloga II, del A)</p> <ol style="list-style-type: none"> <li>Družba</li> <li>pod lastno odgovornostjo izjavljam, da je stroj: Kosilnica za stojedeča delavca / košnja trave       <ol style="list-style-type: none"> <li>Tip / osnovni model</li> <li>Serijska številka</li> <li>Motor: baterija</li> </ol> </li> <li>Skladen je z določili direktiv :       <ol style="list-style-type: none"> <li>Ustanova, ki izda potrdilo: <i>Se ne uporablja</i></li> <li>Skladovanje na usklajene predpise</li> <li>Izmerjen nivo zvočne moči</li> <li>Zagotovljen nivo zvočne moči</li> <li>Obseg košnje</li> <li>Oseba, pooblaščenca za sestavo tehnične knjižice:</li> <li>Kraj in datum</li> </ol> </li> </ol>	<p><b>BS</b> (Prijevod originalnih uputa)</p> <p>EZ izjava o skladnosti (Direktiva o mašinama 2006/42/EZ, Prilog II, deo A)</p> <ol style="list-style-type: none"> <li>Firma</li> <li>Daje izjavu pod vlastitom odgovornošću da je mašina:       <ol style="list-style-type: none"> <li>Tip / Osnovni model</li> <li>Serijski broj</li> <li>Motor: akumulator</li> </ol> </li> <li>skladna s osnovnim zahtjevima direktive:       <ol style="list-style-type: none"> <li>Certifikaciono tijelo: <i>Nije primjenjivo</i></li> <li>Postupanje na usklađene norme</li> <li>Izmjereni nivo zvučne snage</li> <li>Garantovani nivo zvučne snage</li> <li>Širina košenja</li> <li>Osoba ovlaštena za izradu tehničke brošure:</li> <li>Mjesto i datum</li> </ol> </li> </ol>	<p><b>SK</b> (Preklad pôvodného návodu na použitie)</p> <p>ES vyhlásenie o zhode (Smernica o Strojnych zariadeniach 2006/42/ES, Príloha II, časť A)</p> <ol style="list-style-type: none"> <li>Spoločnosť</li> <li>Vyhlasuje na vlastnú zodpovednosť, že stroj: Kosačka so stojacou obsluhou / kosačka na trávu       <ol style="list-style-type: none"> <li>Typ / Základný model</li> <li>Výrobné číslo</li> <li>Motor: akumulátor</li> </ol> </li> <li>Je v zhode s nariadeniami smernice:       <ol style="list-style-type: none"> <li>Certifikačný orgán: <i>Nepoužiteľné</i></li> <li>Odkaz na Harmonizované normy</li> <li>Nameraná úroveň akustického výkonu</li> <li>Zaručená úroveň akustického výkonu</li> <li>Šírka kosenia</li> <li>Osoba autorizovaná na vytvorenie Technického spisu:</li> <li>Miesto a Dátum</li> </ol> </li> </ol>
<p><b>RO</b> (Traducerea manualului fabricantului)</p> <p>CE - Declaratie de Conformitate (Directiva Maşini 2006/42/CE, Anexa II, partea A)</p> <ol style="list-style-type: none"> <li>Societatea</li> <li>Declară pe propria răspundere că maşina: Maşină de tuns iarba cu conducător pedestru / tăiat iarba       <ol style="list-style-type: none"> <li>Tip / Model de bază</li> <li>Număr de serie</li> <li>Motor: baterie</li> </ol> </li> <li>Este în conformitate cu specificațiile directivelor:</li> <li>Organism de certificare: <i>Nu se aplică</i></li> <li>Referință la Standardele armonizate</li> <li>Nivel de putere sonoră măsurat</li> <li>Nivel de putere sonoră garantat</li> <li>Lăimea de tăiere</li> <li>Persoană autorizată să întocmească Dosarul Tehnic</li> <li>Locul și Data</li> </ol>	<p><b>LT</b> (Originalių instrukcijų vertimas)</p> <p>EB atitikties deklaracija (Mašinių direktyva 2006/42/CE, Priedas II, dalis A)</p> <ol style="list-style-type: none"> <li>Bendrovė</li> <li>Prisima atsakomybę, kad įrenginys: Pėsioji operatoriaus valdoma vejojapvė/ žolės pjovimas       <ol style="list-style-type: none"> <li>Tipas / Bazinis Modelis</li> <li>Serijs numeris</li> <li>Varklis: baterija</li> </ol> </li> <li>Atitinka direktyvos pateiktas specifikacijas:       <ol style="list-style-type: none"> <li>Sertifikavimo įstaiga: <i>Netaikoma</i></li> <li>Nuoroda į suderintas Normas</li> <li>Išmatuotas garso galios lygis</li> <li>Užtikrinamas garso galios lygis</li> <li>Pjovimo plotis</li> <li>Autorizuotas asmuo sudaryti Techninį Dokumentaciją:</li> <li>Vieta ir Data</li> </ol> </li> </ol>	<p><b>LV</b> (Instrukciju tulkojums no oriģinālvalodas)</p> <p>EK atbilstības deklarācija (Direktīva 2006/42/EK par mašīnām, pielikums II, daļa A)</p> <ol style="list-style-type: none"> <li>Uzņēmums</li> <li>Uzņemties par to pilnu atbildību, paziņo, ka mašīna: Pēšioji operatoriaus valdoma vejojapvė/ zāles pļaušana       <ol style="list-style-type: none"> <li>Tipa / Bāzes modelis</li> <li>Sērijas numurs</li> <li>Motors: akumulators</li> </ol> </li> <li>Atbilst šādu direktīvu prasībām:       <ol style="list-style-type: none"> <li>Sertifikācijas iestāde: <i>Nav piemērojams</i></li> <li>Atsauce uz harmonizētiem standartiem</li> <li>Izmērītais skaņas intensitātes līmenis</li> <li>Garantētais skaņas intensitātes līmenis</li> <li>Pļaušanas platums</li> <li>Pļinvarotais darbinieks, kas sagatavoja tehnisko dokumentāciju:</li> <li>Vieta un datums</li> </ol> </li> </ol>
<p><b>SR</b> (Prevod originalnih uputstval)</p> <p>EC deklaracija o usaglašenosti (Direktiva o mašinama 2006/42/EC, Prilog II, deo A)</p> <ol style="list-style-type: none"> <li>Preduzeće</li> <li>Daje izjavu pod vlastitom odgovornošću da je mašina: Kosačka sa izpraven vodanč / košenje trave       <ol style="list-style-type: none"> <li>Tip / Osnovni model</li> <li>Serijski broj</li> <li>Motor: akumulator</li> </ol> </li> <li>U skladu s osnovnim zahtevima direktiva:       <ol style="list-style-type: none"> <li>Sertifikaciono telo: <i>Nije primjenljivo</i></li> <li>Postupanje na usklađene norme</li> <li>Izmereni nivo zvučne snage</li> <li>Garantovani nivo zvučne snage</li> <li>Širina košenja.....</li> <li>Osoba ovlašćena za sastavljanje tehničke brošure</li> <li>Mesto i datum</li> </ol> </li> </ol>	<p><b>BG</b> (Превод на оригиналните инструкции)</p> <p>EO декларация за съответствие (Директива Машини 2006/42/EO, Приложение II, част А)</p> <ol style="list-style-type: none"> <li>Дружеството</li> <li>На собствена отговорност декларира, че машината: Косачка с изправен воданч / рязане на трева       <ol style="list-style-type: none"> <li>Вид / Базисен модел</li> <li>Сериен номер</li> <li>Мотор: акумулатор</li> </ol> </li> <li>Е в съответствие със спецификата на директивите:       <ol style="list-style-type: none"> <li>Сertifikaцiонaн орган: <i>He e приложливо</i></li> <li>Базирано на хармонизираните норми</li> <li>Ниво на измерена акустична мощност</li> <li>Гарантирано ниво на акустична мощност</li> <li>Ширина на косене</li> <li>Лице, упълномощено да състави Техническата Документация:</li> <li>Място и дата</li> </ol> </li> </ol>	<p><b>ET</b> (Algupärase kasutusjuhendi tõlge)</p> <p>EÜ vastavusdeklaratsioon (Masinadirektiiv 2006/42/EÜ, Lisa II, osa A)</p> <ol style="list-style-type: none"> <li>Firma</li> <li>Kinnitab omal vastutusel, et masin: Seisva juhiga muruniija / muruniija       <ol style="list-style-type: none"> <li>Tüüp / Põhimudel</li> <li>Matrikkel</li> <li>Mootor: aku</li> </ol> </li> <li>Vastab direktiivide nõuetele:       <ol style="list-style-type: none"> <li>Kinnitav asutus: <i>Ei ole kohaldatav</i></li> <li>Vide ühtlustatud standarditele</li> <li>Mõõdetud helivõimsuse tase</li> <li>Garanteeritud helivõimsuse tase</li> <li>Lõikeaiala</li> <li>Tehnilise Lehe autoriseeritud koostaja:</li> <li>Koht ja Kuupäev</li> </ol> </li> </ol>

**IT** • Il contenuto e le immagini del presente manuale d'uso sono stati realizzati per conto di ST. S.p.A. e sono tutelati da diritto d'autore – È vietata ogni riproduzione o alterazione anche parziale non autorizzata del documento.

**BG** • Съдържанието и изображенията в настоящото ръководство са извършени за ST. S.p.A. и са защитени с авторски права – Забранява се всяко неоторизирано възпроизвеждане или промяна, дори и отчасти на документа.

**BS** • Sadržaj i slike iz ovog korisničkog priručnika napravljeni su isključivo za ST. S.p.A. i zaštićeni su autorskim pravima – zabranjena je svaka neovlaštena reprodukcija ili izmjena dokumenta, djelomično ili u potpunosti.

**CS** • Obsah a obrázky v tomto návodu k použití byly zpracovány jménem společnosti ST. S.p.A. a jsou chráněny autorským právem – Reprodukce či nepovolené pozměňování tohoto dokumentu, a to i částečné, je zakázáno.

**DA** • Indhold og illustrationer i denne vejledning er blevet skabt på vegne af ST. S.p.A. og er beskyttet af ophavsret – Enhver gengivelse eller ændring, også delvis, af dokumentet uden autorisation hertil er forbudt.

**DE** • Inhalt und Bilder dieser Bedienungsanleitung wurden im Namen von ST. S.p.A. erstellt und sind urheberrechtlich geschützt – Jede nicht genehmigte Vervielfältigung oder Veränderung, auch auszugsweise, dieses Dokuments ist verboten.

**EL** • Το περιεχόμενο και οι εικόνες στο παρόν εγχειρίδιο χρήσης δημιουργήθηκαν για λογαριασμό της εταιρείας ST. S.p.A. και προστατεύονται από πνευματικά δικαιώματα – Απαγορεύεται οποιαδήποτε αναπαραγωγή ή τροποποίηση, έστω και μερική, του εγχειρίδιου χωρίς έγκριση.

**EN** • The content and images in this User Manual were produced expressly for ST. S.p.A. and are protected by copyright – any unauthorized reproduction or modification to the document, either partially or in full, is prohibited.

**ES** • El contenido y las imágenes del presente manual de uso han sido creados por ST. S.p.A. y están protegidos por los derechos de autor – Se prohíbe toda reproducción o modificación, incluso parcial, no autorizada del documento.

**ET** • Käesoleva kasutusjuhendi sisu ja kujutised on toodetud konkreetselt ettevõttele ST. S.p.A. ja neile rakendub autoriõigussaadus – dokumendi igasuguse osaline või täielik ilma loata reprodutseerimine või muutmine on keelatud.

**FI** • Tämän käyttöoppaan sisältö ja kuvat on valmistettu ST. S.p.A. -yhtiön toimesta ja niitä suojaa tekijänoikeuslaki. – Asiakirjan kaikenlainen kopioiminen tai muuttaminen, osittainkin, on kielletty ilman erityistä lupaa.

**FR** • Le contenu et les images du présent manuel d'utilisation ont été réalisés pour le compte de ST. S.p.A. et sont protégés par un droit d'auteur – Toute reproduction ou modification non autorisée, même partielle, du document, est interdite.

**HR** • Sadržaj i slike u ovom priručniku za uporabu izrađeni su za tvrtku ST. S.p.A. te su obuhvaćeni autorskim pravima – Zabranjuje se neovlašteno umnožavanje ili prilagodba, djelomična ili u cijelosti, ovog dokumenta.

**HU** • Ennek a használati útmutatónak a tartalma és a benne szereplő képek kizárólag a ST. S.p.A. számára készültek és szerzői joggal védettek – tilos a dokumentum bármely részének vagy egészének engedély nélküli sokszorosítása és módosítása.

**LT** • Šio naudotojų vadovo turinys ir paveikslėliai skirti tik „ST. S.p.A.“ ir yra saugomi autorių teisėmis – dokumentą atgaminti ar modifikuoti, visiškai arba iš dalies, yra draudžiami.

**LV** • Šis lietotāja rokasgrāmatas saturs un attēli ir veidoti tikai ST. S.p.A. un ir aizsargāti ar autortiesībām. Jebkāda dokumenta vai tā daļas prettiesiska kopēšana vai pārveide ir stingri aizliegta.

**MK** • Содржината и сликите во Упатството за корисникот се подготвени исклучиво за ST. S.p.A. и се заштитени со авторски права – забрането е секое делумно или целосно неовластено репродуцирање или измена на документот.

**NL** • De inhoud en de afbeeldingen van deze gebruikshandleiding werden gerealiseerd voor rekening van ST. S.p.A. en zijn beschermd door het auteursrecht – Elke niet-geautoriseerde reproductie of wijziging, ook gedeeltelijke, van het document is verboden.

**NO** • Innholdet og bildene i denne brukerveiledningen er utført på oppdrag fra ST. S.p.A. og er beskyttet ved opphavsrett – Enhver gjengivelse eller endring, selv kun delvis, er forbudt.

**PL** • Treść oraz ilustracje zawarte w niniejszej instrukcji obsługi powstały na zlecenie spółki ST. S.p.A. i są chronione prawami autorskimi – Zabrania się wszelkiego kopiowania bądź modyfikowania, także częściowego, niniejszego dokumentu bez uzyskania stosownej zgody.

**PT** • As imagens e os conteúdos contidos no presente Manual do Utilizador foram expressamente criados para uso exclusivo da ST. S.p.A., encontrando-se protegidos por direitos de autor. Qualquer tipo de reprodução ou alteração, parcial ou integral, não autorizadas deste Manual estão expressamente proibidas.

**RO** • Conținutul și imaginile din manualul de utilizare de față au fost realizate în numele ST. S.p.A. și sunt protejate de drepturi de autor – Este interzisă orice reproducere sau modificare chiar și parțială neautorizată a documentului.

**RU** • Тесты и изображения, содержащиеся в настоящем руководстве, были созданы в интересах ST. S.p.A. и защищены авторскими правами – Любое несанкционированное воспроизведение или изменение документа запрещено.

**SK** • Obsah a obrázky v tomto návode na používanie boli spracované menom spoločnosti ST. S.p.A. a sú chránené autorským právom – Reprodukcie či nepovolené pozměňovanie tohto dokumentu, a to aj čiastočné, je zakázané.

**SL** • Vsebine in slike v tem uporabniškem priručniku so izdelane za podjetje ST. S.p.A. in so zaščitene z avtorskimi pravicami – vsakršno nepooblaščenno razmnoževanje ali spreminjanje dokumenta, v celoti ali delno, je prepovedano.

**SR** • Sadržaj i slike ovog priručnika za upotrebu na napravljeni u ime ST. S.p.A. i zaštićeni su autorskim pravima – Zabranjena je svaka potpuna ili delimična reprodukcija ili izmena dokumenta bez odobrenja.

**SV** • Innehållet och bilderna i denna användarhandbok har framställts för ST. S.p.A. och skyddas av upphovsrätt – all form av reproduktion eller ändring, även partiell, som inte auktoriserats är förbjuden.

**TR** • Bu Kullanıcı Kilavuzundaki içerik ve resimler açığa ST. S.p.A. için üretilmiştir ve telif hakkı ile korunmaktadır – dokümanın izinsiz olarak tamamen ya da kısmen herhangi bir şekilde çoğaltılması ya da değiştirilmesi yasaktır.



.....	 <b>LWA</b>  <b>dB</b>
Type: .....	
Art.N ..... ..... -s/n .....	



**FR**

Cet appareil,  
ses accessoires,  
piles et cordons  
se recyclent

À DÉPOSER  
EN MAGASIN  
OU  
À DÉPOSER  
EN DÉCHÈTERIE

Points de collecte sur [www.quefairedemesdechets.fr](http://www.quefairedemesdechets.fr)  
Privilégiez la réparation ou le don de votre appareil !



**FR**

**ST. S.p.A.**  
Via del Lavoro, 6  
31033 Castelfranco Veneto (TV) ITALY

**STIGA LTD (UK Importer)**  
Unit 8, Bluewater Estate Plympton,  
Devon, PL7 4JH, England