

MP 84 Li 56 V1
MP 98 Li 56 V2
SD 98 Li 56 V1
SD 108 Li 56 V2

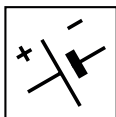
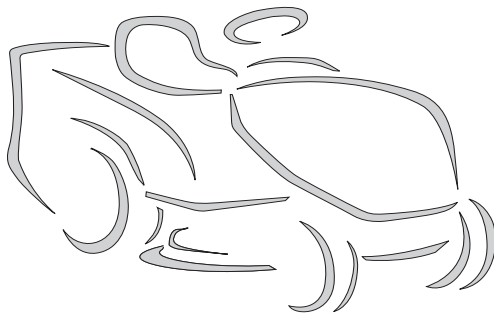

IT Tosaerba con conducente a bordo seduto, alimentato a batteria
MANUALE DI ISTRUZIONI

ATTENZIONE: prima di usare la macchina, leggere attentamente il presente libretto.

BG Косачка със седнал водач, Акумулаторна
УПЪТВАНЕ ЗА УПОТРЕБА

ВНИМАНИЕ: преди да използвате машината прочетете внимателно настоящата книжка.

BS Traktorska kosilica (traktorčić), na bateriju
UPUTSTVO ZA UPOTREBU

PAŽNJA: prije nego što koristite ovu mašinu, pažljivo pročitajte priručnik s uputama.

CS Sekačka se sedící obsluhou, akumulátorový pohon
NÁVOD K POUŽITÍ

UPOZORNĚNÍ: před použitím stroje si pozorně přečtěte tento návod k použití.

DA Havetraktor, batteridrevet
BRUGSANVISNING

ADVARSEL: læs instruktionsbogen omhyggeligt igennem, før du tager denne maskine i brug.

DE Aufsitzmäher (Rasenmäher mit sitzendem Bediener, batterie betrieben)
GEBRAUCHSANWEISUNG

ACHTUNG: vor Inbetriebnahme des Geräts die Gebrauchsanleitung aufmerksam lesen.

EL Χλοοκοπτικό τρακτέρ με εποχούμενο χειριστή, μηχανή μπαταρίας
ΟΔΗΓΙΕΣ ΧΡΗΣΗΣ

ΠΡΟΣΟΧΗ: πριν χρησιμοποιήσετε το μηχανήμα, διαβάστε προσεκτικά το παρόν εγχειρίδιο.

EN Ride-on lawnmower with seated operator, battery-operated
OPERATOR'S MANUAL

WARNING: read thoroughly the instruction booklet before using the machine.

ES Cortadora de pasto con conductor sentado, alimentado con batería
MANUAL DE INSTRUCCIONES

ATENCIÓN: antes de utilizar la máquina, leer atentamente el presente manual.

ET Istuva juhiga muruniitja, akutoitega
KASUTUSJUHE

TÄHELEPANU: enne masina kasutamist lugeda tähelepanelikult antud kasutusjuhendit.

FI Päältäajettava ruohonleikkuri, akkukäyttöinen
KÄYTTÖOHJEET

VAROITUS: lue käyttöopas huolellisesti ennen koneen käyttöä.

FR Tondeuse à gazon à conducteur assis, alimentation par batterie
MANUEL D'UTILISATION

ATTENTION: lire attentivement le manuel avant d'utiliser cette machine.

- HR** Sjedeca kosilica trave s operaterom, baterijsko napajanje
PRIRUČNIK ZA UPORABO
POZOR: prije uporabe stroja, pažljivo pročitajte ovaj priručnik.
- HU** Vezetőülékes fűnyírógép, akkumulátoros
HASZNÁLATI UTASÍTÁS
FIGYELEM! a gép használata előtt olvassa el figyelmesen a jelen kézikönyvet.
- LT** Balninė vejapjovė su sėdinčiu operatoriumi, maitinimas akumuliatoriumi
NAUDOJIMO INSTRUKCIJOS
DĖMESIO: prieš naudojant įrenginį, atidžiai perskaityti šį naudotojo vadovą.
- LV** Sēžot vadāma zālienu plaujmašina, akumulatora barošanas avots
LIETOŠANAS INSTRUKCIJA
UZMANĪBU: pirms aparāta lietošanai rūpīgi izlasiet doto instrukciju.
- MK** Тревокосачка со седнат управувач, на батерии
УПАТСТВА ЗА УПОТРЕБА
ВНИМАНИЕ: прочитайте го внимателно ова упатство пред да ја користите машината.
- NL** Grasmaaier met zittende bediener, voeding met accu
GEBRUIKERSHANDLEIDING
LET OP: vooraleer de machine te gebruiken, dient men deze handleiding aandachtig te lezen.
- NO** Sittegressklipper, batteridrevet
INSTRUKSJONSBOK
ADVARSEL: les denne bruksanvisningen nøye før du bruker maskinen.
- PL** Kosiarzka z operatorem jadącym, w pozycji siedzącej na maszynie,
zasilana za pomocą akumulatora
INSTRUKCJE OBSŁUGI
OSTRZEŻENIE: przed użyciem maszyny, należy uważnie przeczytać niniejszą instrukcję.
- PT** Corta-relvas para operador sentado, alimentado por bateria
MANUAL DE INSTRUÇÕES
ATENÇÃO: antes de usar a máquina, leia atentamente o presente manual.
- RO** Mașină pe baterii de tuns iarba cu șofer la volan
MANUAL DE INSTRUCȚIUNI
ATENȚIE: înainte de a utiliza mașina, citiți cu atenție manualul de față.
- RU** Ездовая косилка с сиденьем, питается от аккумулятора
РУКОВОДСТВО ПО ЭКСПЛУАТАЦИИ
ВНИМАНИЕ: прежде чем пользоваться оборудованием, внимательно прочтите это руководство по эксплуатации.
- SK** Akumulátorová kosačka so sediacou obsluhou
NÁVOD NA POUŽITIE
UPOZORNENIE: pred použitím stroja si pozorne prečítajte tento návod.
- SL** Traktorska kosilnica, napajanje z baterijo
PRIROČNIK ZA UPORABO
POZOR: preden uporabite stroj, pazljivo preberite priročnik z navodili.
- SR** Traktorska kosačica (traktorčić), na bateriju
PRIRUČNIK SA UPUTSTVIMA
PAŽNJA: pre korišćenja mašine pažljivo pročitati ovaj priručnik.
- SV** Åkgräsklippare och främre klippning, batteridrivna
BRUKSANVISNING
VARNING: läs igenom hela detta häfte innan du använder maskinen.
- TR** Oturan sürücülü çim biçme makinesi, kumandalı bataryalı
KULLANIM KILAVUZU
DİKKAT: makineyi kullanmadan önce talimatlar içeren kılavuzu dikkatle okuyun.

ITALIANO - Istruzioni Originali	IT
БЪЛГАРСКИ - Инструкция за експлоатация	BG
BOSANSKI - Prijevod originalnih uputa	BS
ČESKY - Překlad původního návodu k používání	CS
DANSK - Oversættelse af den originale brugsanvisning	DA
DEUTSCH - Übersetzung der Originalbetriebsanleitung	DE
ΕΛΛΗΝΙΚΑ - Μετάφραση των πρωτοτύπων οδηγιών	EL
ENGLISH - Translation of the original instruction	EN
ESPAÑOL - Traducción del Manual Original	ES
EESTI - Algupärase kasutusjuhendi tõlge	ET
SUOMI - Alkuperäisten ohjeiden käännös	FI
FRANÇAIS - Traduction de la notice originale	FR
HRVATSKI - Prijevod originalnih uputa	HR
MAGYAR - Eredeti használati utasítás fordítása	HU
LIETUVIŠKAI - Originalių instrukcijų vertimas	LT
LATVIEŠU - Instrukciju tulkojums no oriģināl valodas	LV
МАКЕДОНСКИ - Превод на оригиналните упатства	MK
NEDERLANDS - Vertaling van de oorspronkelijke gebruiksaanwijzing	NL
NORSK - Oversettelse av den originale bruksanvisningen	NO
POLSKI - Tłumaczenie instrukcji oryginalnej	PL
PORTUGUÊS - Tradução do manual original	PT
ROMÂN - Traducerea manualului fabricantului	RO
РУССКИЙ - Перевод оригинальных инструкций	RU
SLOVENSKY - Preklad pôvodného návodu na použitie	SK
SLOVENŠČINA - Prevod izvornih navodil	SL
SRPSKI - Prevod originalnih uputstva	SR
SVENSKA - Översättning av bruksanvisning i original	SV
TÜRKÇE - Orijinal Talimatların Tercümesi	TR

3

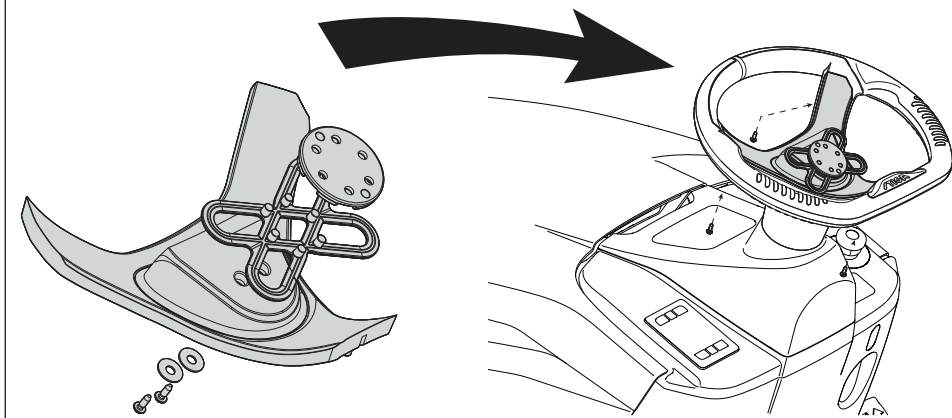
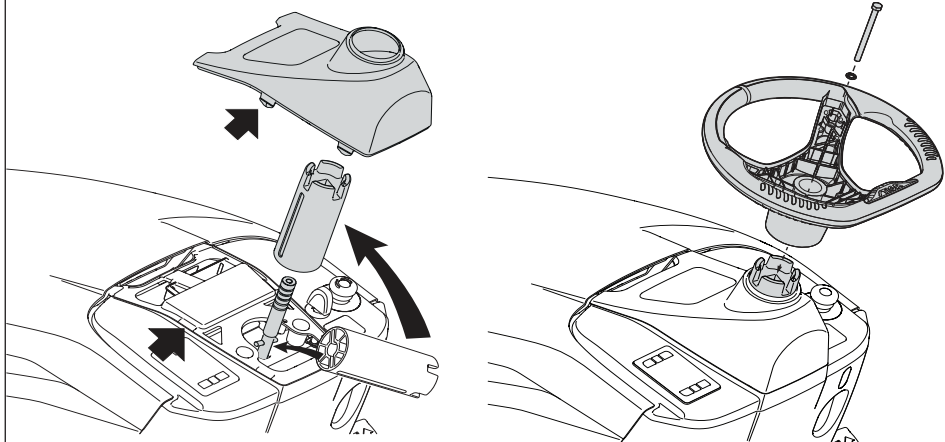

4

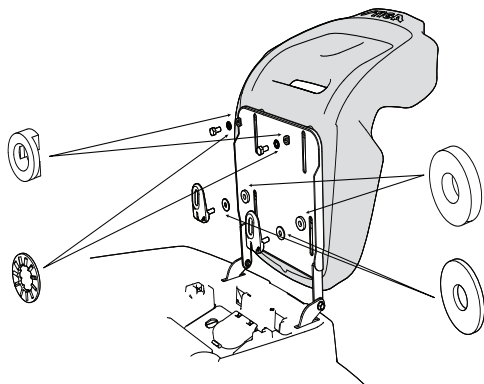

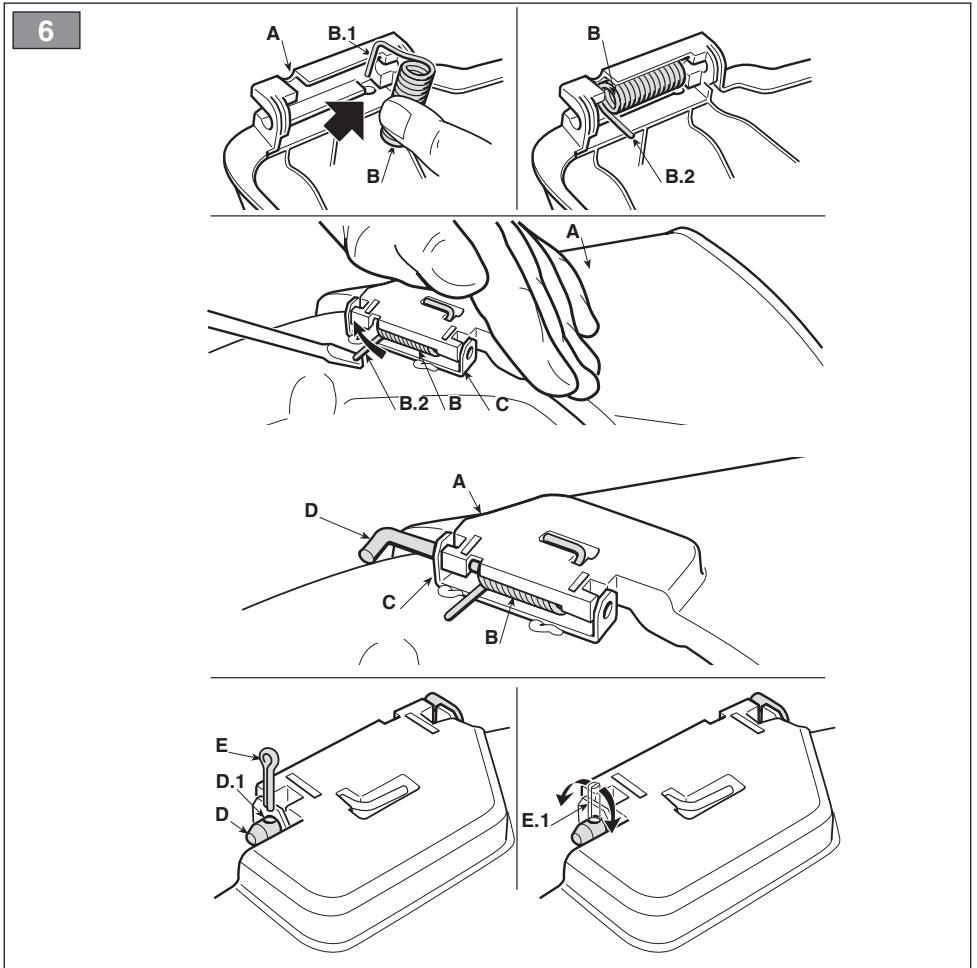
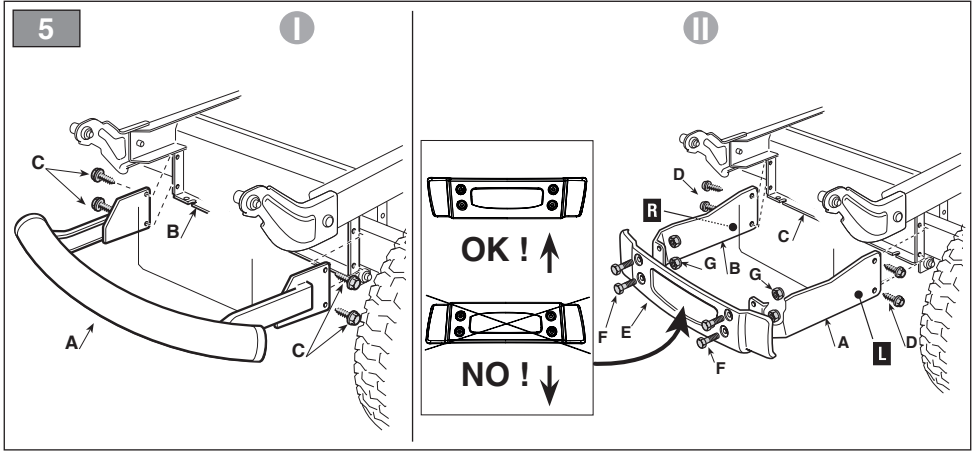

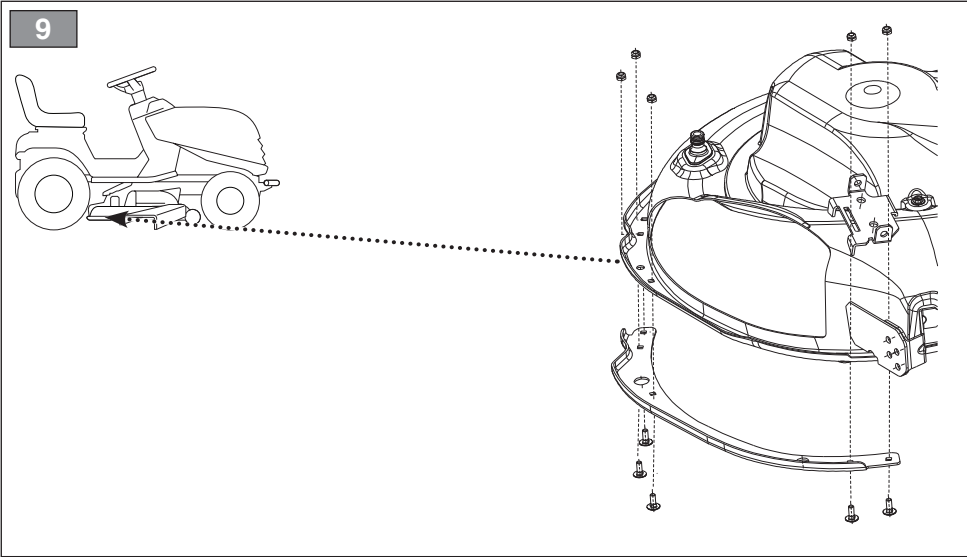
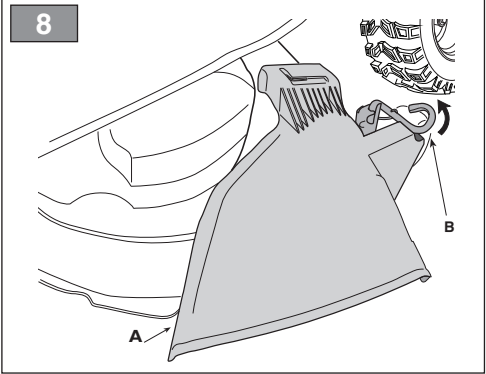
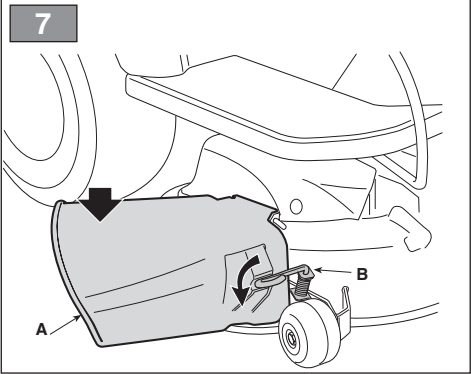

10

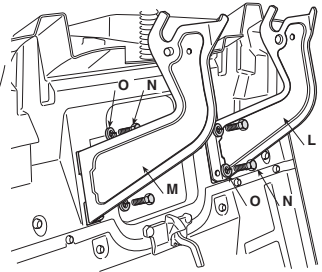
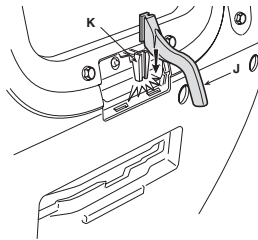
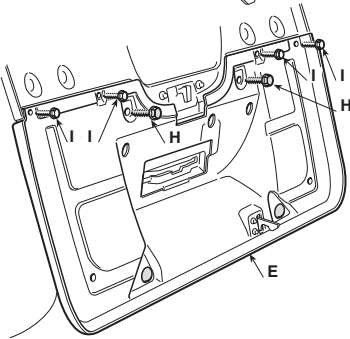
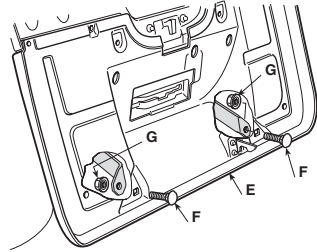
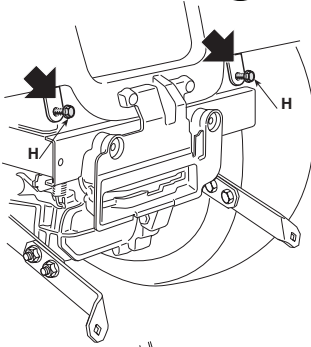
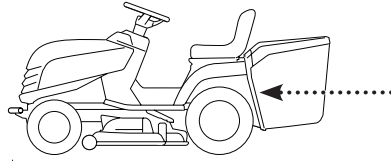

11



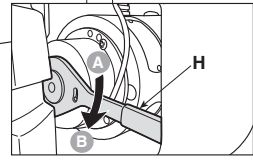
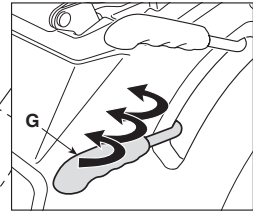
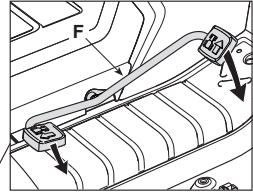
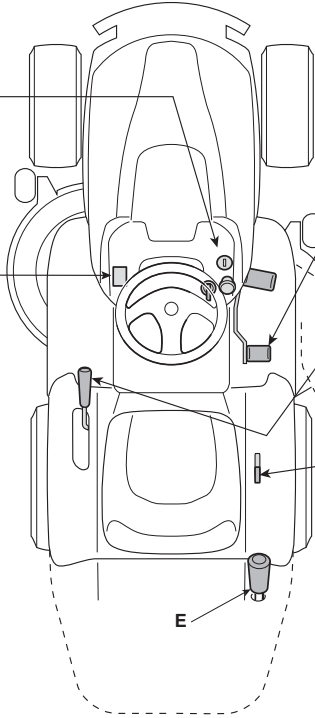
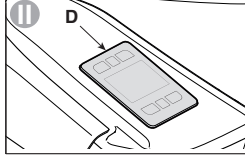
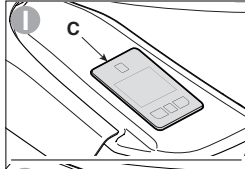
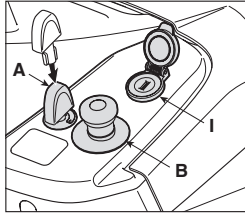

E

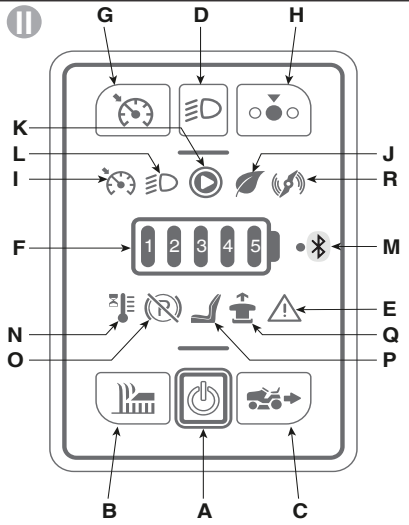
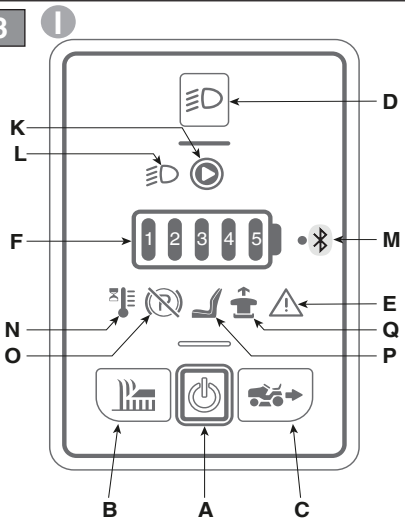

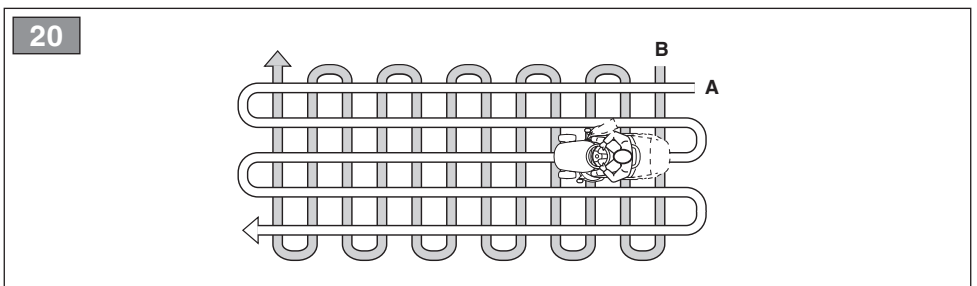
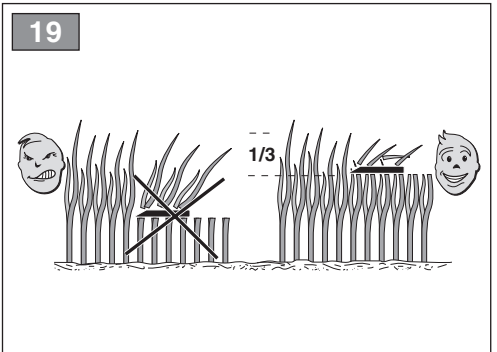
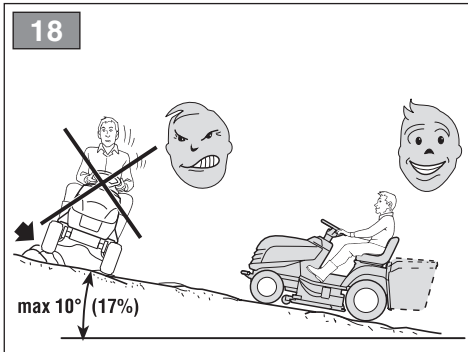
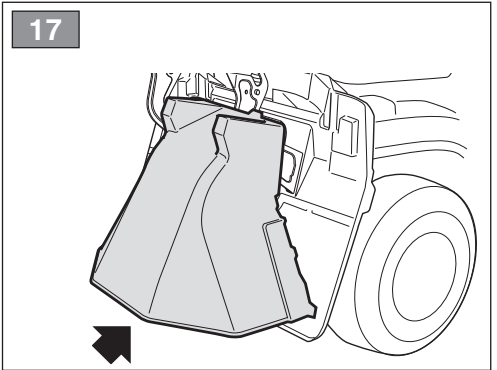
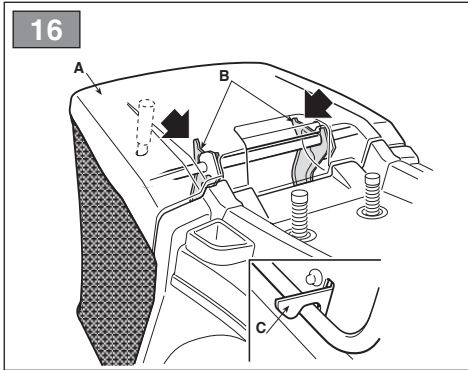
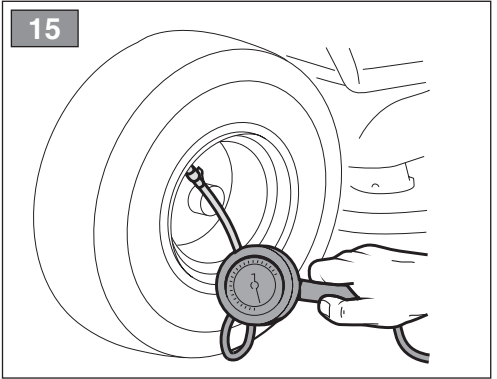
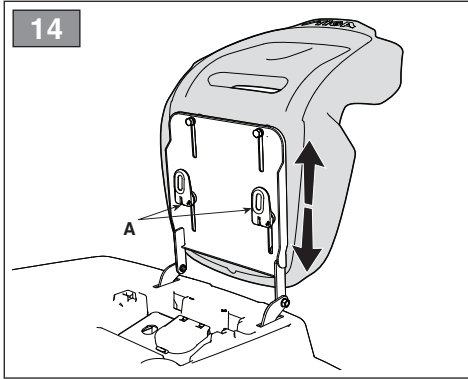

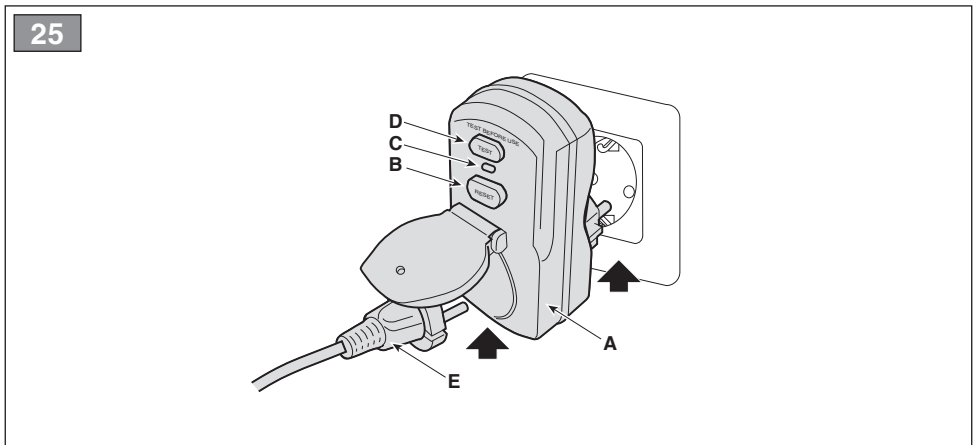
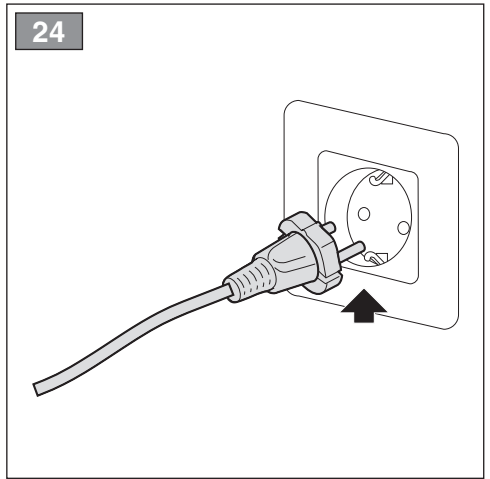
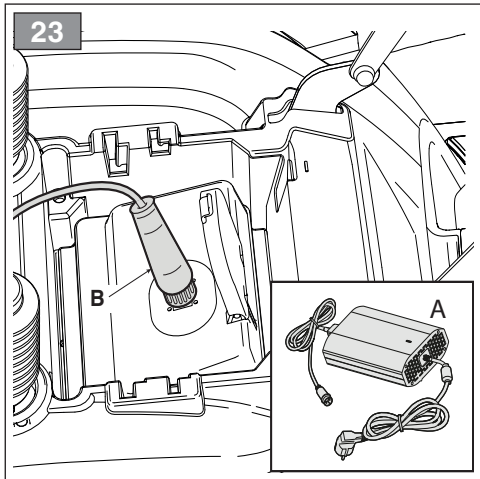
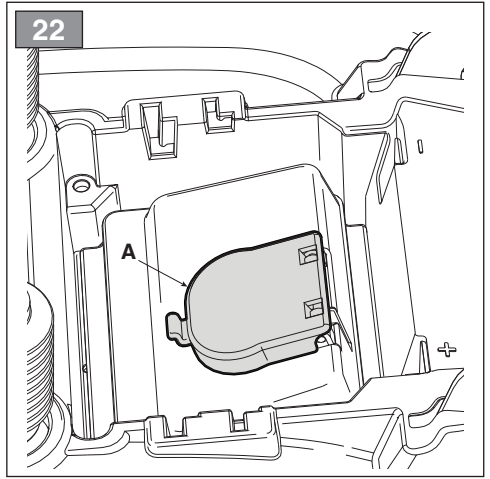
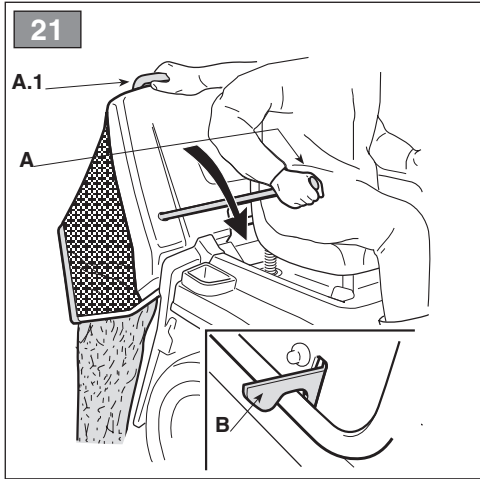

26

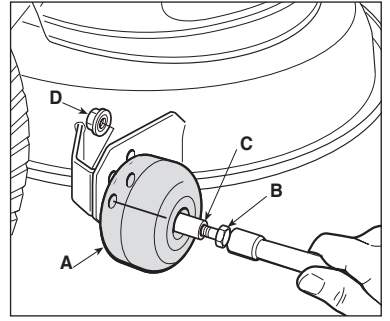
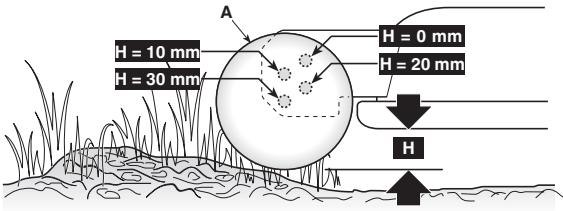

27

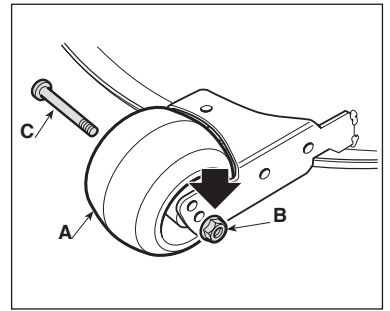
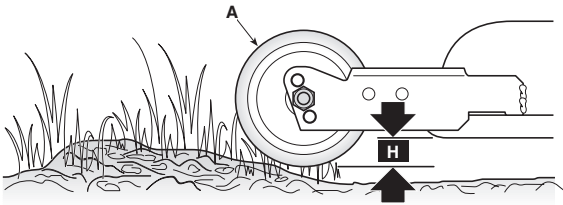

28

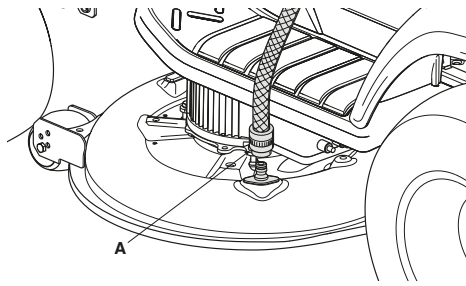

29

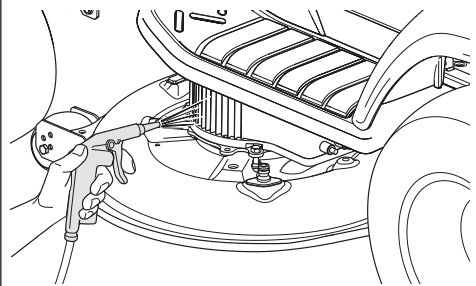

30

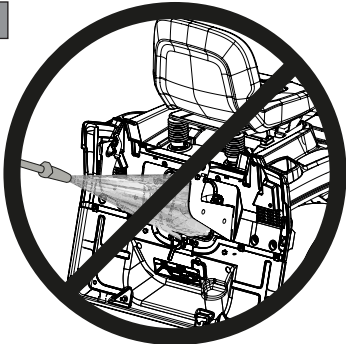

31

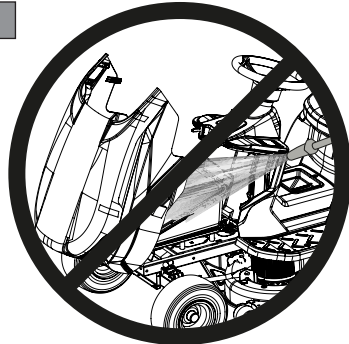

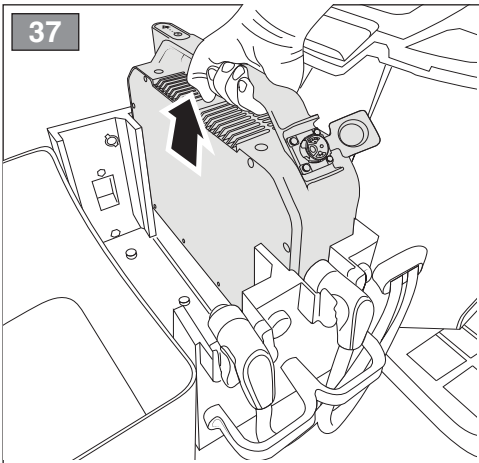
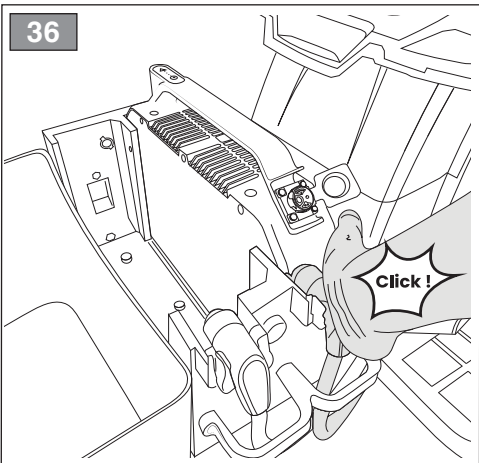
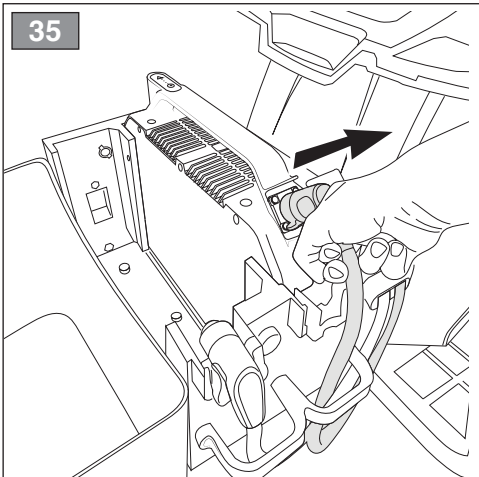
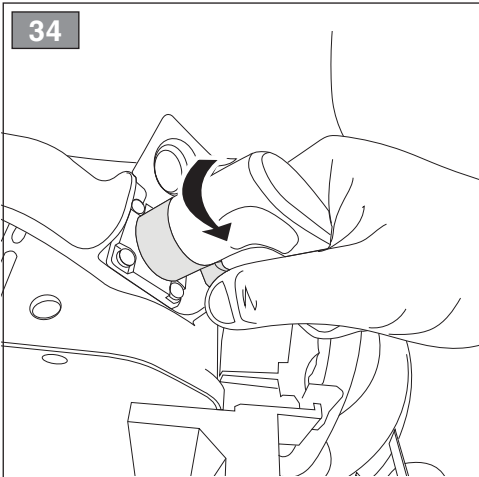
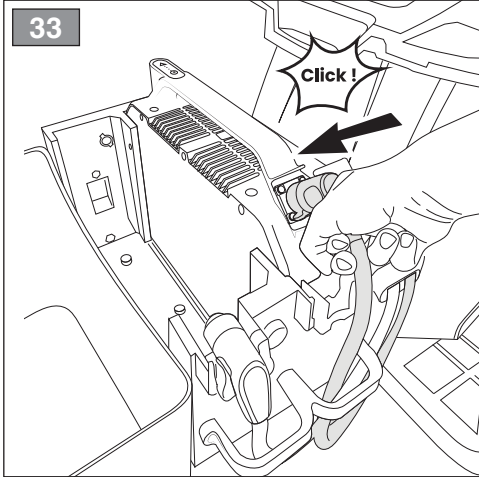
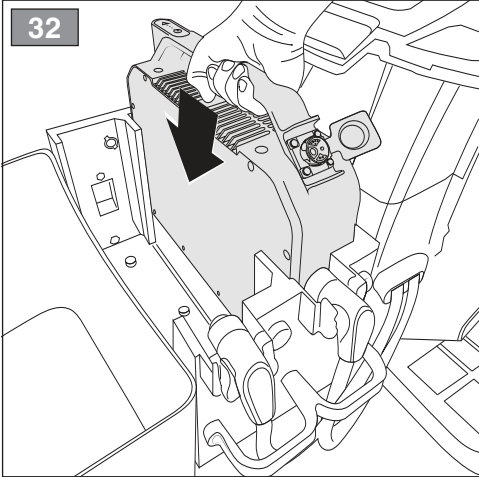

38

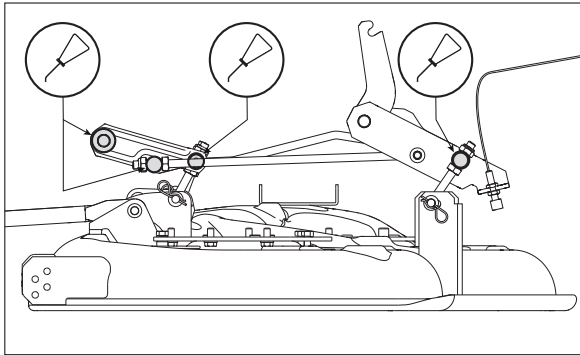
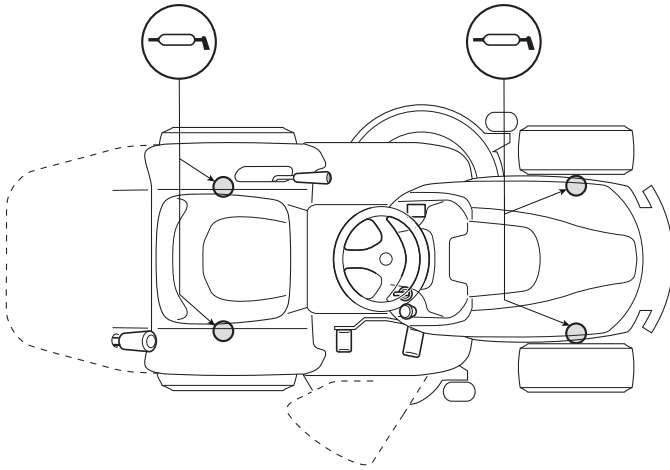

39

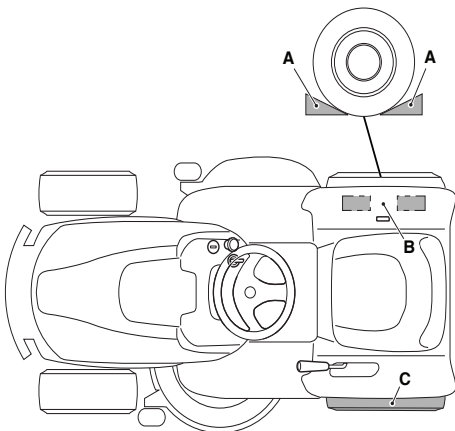

40

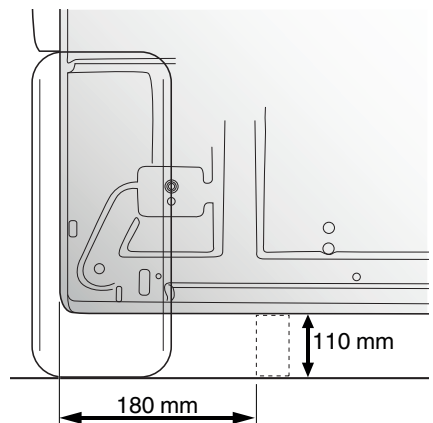

41

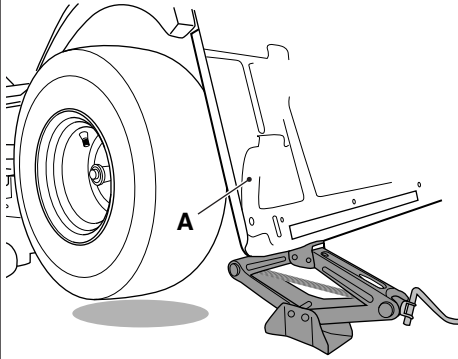

42

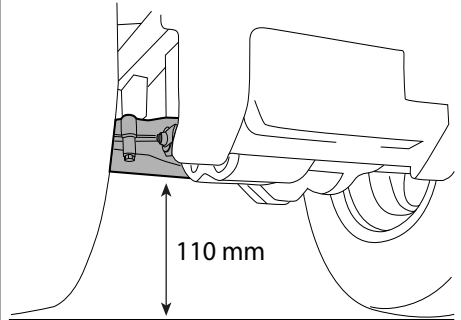

43

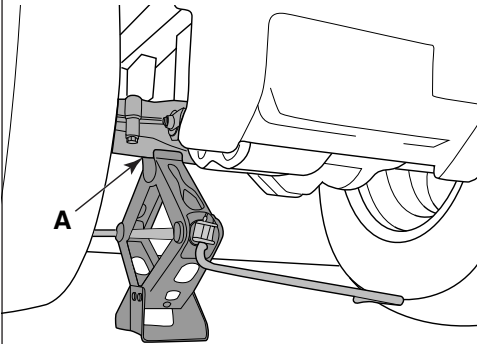

44

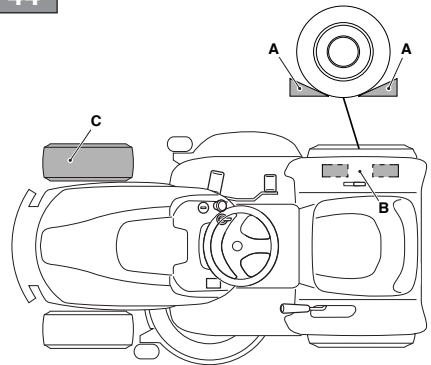

45

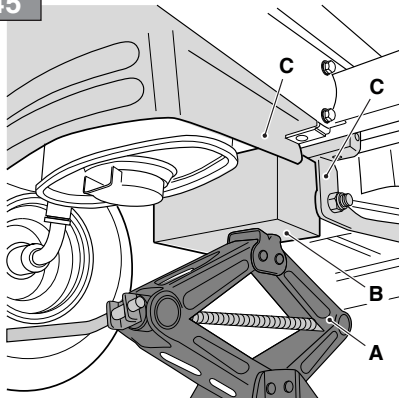

46

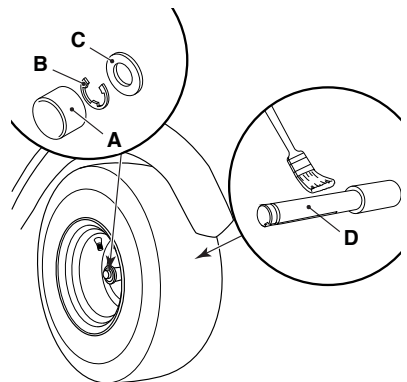

47

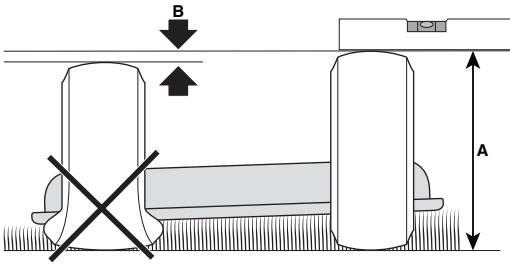

48

I

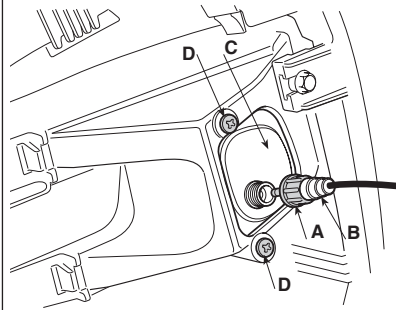

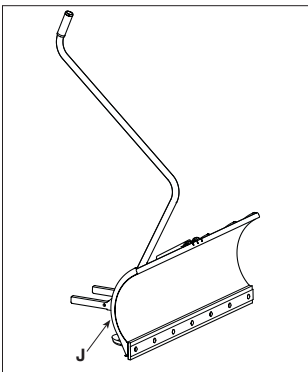
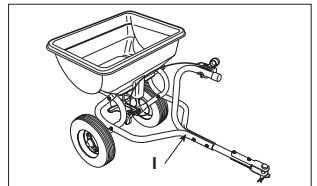
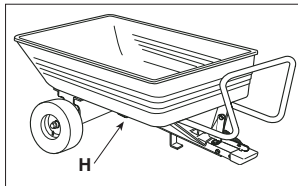
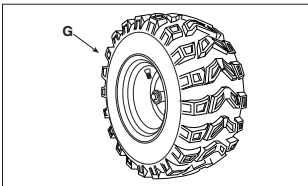
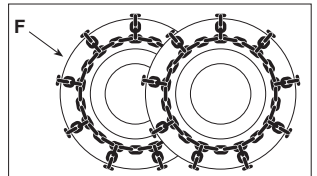
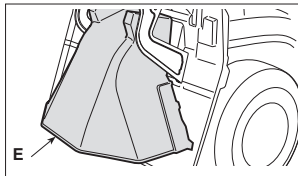
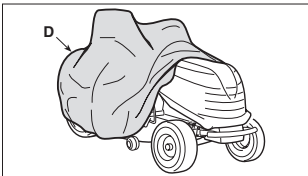
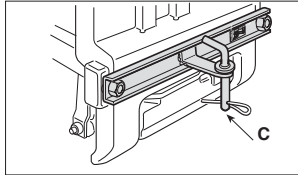
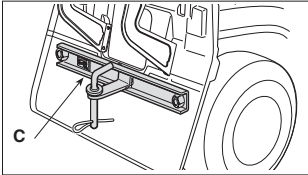
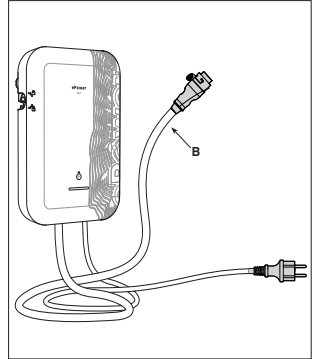
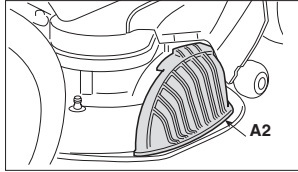
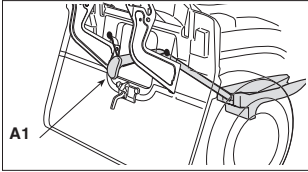

[1]	DATI TECNICI		MP84 Li 56 V1	MP98 Li 56 V2
[2]	Tensione di alimentazione MAX	V / d.c.	58,8	
[3]	Tensione di alimentazione NOMINAL	V / d.c.	50,4	
[4]	Velocità mass. di funzionamento motore	min ⁻¹	3000	3200
[5]	Batteria Nota: non equipaggiato di batteria		[5.A] Agli ioni di Litio (Li-on)	
[6]	Capacità massima del pacco batterie	Ah	80	
[7]	Carica batteria (182050002/0)	V	58,8	
		Hz	50/60	
		A	5	
[8.1]	Massima durata della carica (una batteria)	h (@ V)	~ 8 (220)	
[8.2]	Massima durata della carica (due batterie)	h (@ V)	~ 16 (220)	
[7]	Carica batteria	V	58,8	
		Hz	50/60	
		A	18	
[8.1]	Massima durata della carica (una batteria)	h (@ V)	~ 2 (220)	
[8.2]	Massima durata della carica (due batterie)	h (@ V)	~ 4.5 (220)	
[9]	Potenza motore trazione	kW	1,2	
[10]	Potenza motore lame	kW	1,5	
[11]	Bande di frequenza di funzionamento dell'apparecchiatura radio	MHz	2400 ÷ 2483.5	
[12]	Massima potenza a radiofrequenza trasmessa nelle bande di frequenza in cui opera l'apparecchiatura radio	dBm	3	
[13]	Pneumatici anteriori		13 x 5,00-6 (15 x 5,00-6)	
[14]	Pneumatici posteriori		18 x 8,50-8 (18 x 6,50-8)	
[15]	Pressione gonfiaggio anteriore	bar bar	**	
[16]	Pressione gonfiaggio posteriore	bar	**	
[17]	Massa senza batteria*	kg	168,5	187,5
[18]	Raggio minimo di erba non tagliata	cm	80	70
[19]	Altezza di taglio	cm	3 ÷ 8,5	
[20]	Larghezza di taglio	cm	84	98
[21]	Velocità di avanzamento (indicativa), in marcia avanti	km/h	9,5	
[22]	Velocità di avanzamento (indicativa), in retromarcia	km/h	4,5	
[23]	Inclinazione massima consentita	° / %	10° / 17%	
[24]	Dimensioni			
[25]	Lunghezza	mm	-	-
[26]	Lunghezza con sacco (Lunghezza senza sacco)	mm	2217 ÷ 2340 (1814)	2340 (1814)
[27]	Larghezza	mm	902	1020
[28]	Larghezza con deflettore di scarico laterale (Larghezza senza deflettore di scarico laterale)		-	-

[1]	DATI TECNICI		MP84 Li 56 V1	MP98 Li 56 V2
[29]	Altezza	mm	1068 ÷ 1098	
[30]	Codice dispositivo di taglio		82004358/0 - 82004359/0	82004362/0 - 82004363/0
			82004360/0 - 82004361/0	82004364/0 - 82004346/0
[31]	Livello di pressione acustica (max.)	dB(A)	82,6	84,9
[32]	Incertezza di misura	dB(A)	3,0	3,0
[33]	Livello di potenza acustica misurato (max.)	dB(A)	98,21	99,14
[32]	Incertezza di misura	dB(A)	0,70	0,81
[34]	Livello di potenza acustica garantito	dB(A)	99	100
[35]	Livello di vibrazioni al posto di guida (max.)	m/s ²	0,434	0,430
[32]	Incertezza di misura	m/s ²	1,5	1,5
[36]	Livello di vibrazioni al volante (max.)	m/s ²	0,464	0,651
[32]	Incertezza di misura	m/s ²	1,5	1,5

* Per il dato specifico, fare riferimento a quanto indicato nell'etichetta di identificazione della macchina.

**Vedere la pressione indicata sui pneumatici

[1]	DATI TECNICI		SD98 Li 56 V1	SD108 Li 56 V2
[2]	Tensione di alimentazione MAX	V / d.c.	58,8	
[3]	Tensione di alimentazione NOMINAL	V / d.c.	50,4	
[4]	Velocità mass. di funzionamento motore	min ⁻¹	3000	3200
[5]	Batteria Nota: non equipaggiato di batteria		[5.A] Agli ioni di Litio (Li-on)	
[6]	Capacità massima del pacco batterie	Ah	80	
[7]	Carica batteria (182050002/0)	V	58,8	
		Hz	50/60	
		A	5	
[8.1]	Massima durata della carica (una batteria)	h (@ V)	~ 8 (220)	
[8.2]	Massima durata della carica (due batterie)	h (@ V)	~ 16 (220)	
[7]	Carica batteria	V	58,8	
		Hz	50/60	
		A	18	
[8.1]	Massima durata della carica (una batteria)	h (@ V)	~ 2 (220)	
[8.2]	Massima durata della carica (due batterie)	h (@ V)	~ 4.5 (220)	
[9]	Potenza motore trazione	kW	1,2	
[10]	Potenza motore lame	kW	1,5	
[11]	Bande di frequenza di funzionamento dell'apparecchiatura radio	MHz	2400 ÷ 2483.5	
[12]	Massima potenza a radiofrequenza trasmessa nelle bande di frequenza in cui opera l'apparecchiatura radio	dBm	3	
[13]	Pneumatici anteriori		13 x 5,00-6 (15 x 5,00-6)	
[14]	Pneumatici posteriori		18 x 8,50-8	

[1]	DATI TECNICI		SD98 Li 56 V1	SD108 Li 56 V2
[15]	Pressione gonfiaggio anteriore 13 x 5,00-6 15 x 5,00-6	bar	**	
		bar	**	
[16]	Pressione gonfiaggio posteriore	bar	**	
[17]	Massa senza batteria*	kg	140	149
[18]	Raggio minimo di erba non tagliata	cm	70	65
[19]	Altezza di taglio	cm	3 ÷ 8,5	
[20]	Larghezza di taglio	cm	98	108
[21]	Velocità di avanzamento (indicativa), in marcia avanti	km/h	9,5	
[22]	Velocità di avanzamento (indicativa), in retromarcia	km/h	4,5	
[23]	Inclinazione massima consentita	° / %	10° / 17%	
[24]	Dimensioni			
[25]	Lunghezza	mm	1647	
[26]	Lunghezza con sacco (Lunghezza senza sacco)	mm	-	-
[27]	Larghezza	mm	-	-
[28]	Larghezza con deflettore di scarico laterale (Larghezza senza deflettore di scarico laterale)	mm	1198 (1051)	1312 (1101)
[29]	Altezza	mm	1068 ÷ 1098	
[30]	Codice dispositivo di taglio		82004346/0	82004357/0
[31]	Livello di pressione acustica (max.)	dB(A)	83,7	82,6
[32]	Incertezza di misura	dB(A)	3,0	3,0
[33]	Livello di potenza acustica misurato (max.)	dB(A)	98,13	96,59
[32]	Incertezza di misura	dB(A)	1,42	1,14
[34]	Livello di potenza acustica garantito	dB(A)	100	98
[35]	Livello di vibrazioni al posto di guida (max.)	m/s ²	0,430	0,408
[32]	Incertezza di misura	m/s ²	1,5	1,5
[36]	Livello di vibrazioni al volante (max.)	m/s ²	0,556	0,320
[32]	Incertezza di misura	m/s ²	1,5	1,5

* Per il dato specifico, fare riferimento a quanto indicato nell'etichetta di identificazione della macchina.

**Vedere la pressione indicata sui pneumatici

[Fig. 49]	ACCESSORI A RICHIESTA	
[49.A1] [49.A2]	Kit "mulching"	✓
[49.B1]	Carica batteria rapido - spina EU	279010104/ST1 (18A)
[49.B2]	Carica batteria rapido - spina UK	279010104/UKS (18A)
[49.C]	Kit traino	✓
[49.D]	Telo di copertura	✓
[49.E]	Kit di protezione scarico posteriore (<i>solo per modelli MP series</i>)	✓
[49.F]	Kit catene da neve	✓
[49.G]	Ruote da fango/neve	✓
[49.H]	Rimorchio	✓
[49.I]	Spargitore	✓
[49.J]	Pala da neve	✓

[43]	PRESA AUSILIARIA PER ACCESSORI USB	✓
[43.A]	Tensione e corrente di carica (Uscita USB)	5V / 2.1A
[43.B]	Tipo	YM11081201
[43.C]	Nome e indirizzo del Costruttore	Yeming International (HK) Limited Huizhou Yeming Electronic Co.,LTD 2nd Building,The 3rd Daxin Industrial Area,Zhongkai high-tech district,Huizhou,China.516029

[1] BG - ТЕХНИЧЕСКИ ДАННИ

- [2] Напрежение на захранване MAX
 [3] Напрежение на захранване NOMINAL
 [4] Максимална скорост на функциониране на двигателя
 [5] Акумулатор (забележка: не е оборудван с батерия)
 [6] Капацитет на акумулатора
 [7] Зарядно устройство
 [8.1] Максимална продължителност на зареждането (една батерия)
 [8.2] Максимална продължителност на зареждането (две батерии)
 [9] Мощност на тяговия мотор
 [10] Мощност на мотора на ножа
 [11] Радиочестотни ленти, в които работи радиосъоръжението
 [12] Максимална радиочестотна мощност, предавана в честотните ленти, в които работи радиосъоръжението
 [13] Предни гуми
 [14] Задни гуми
 [15] Налягане предно напompване
 [16] Налягане задно напompване
 [17] Маса (без батерия*)
 [18] Минимален радиус на неподрязана трева
 [19] Височина на косене
 [20] Ширина на косене
 [21] Скорост на движение (ориентировъчна), на преден ход
 [22] Скорост на движение (ориентировъчна), на заден ход
 [23] Максимално допустим наклон
 [24] Размери
 [25] Дължина
 [26] Дължина с торбата за събиране на трева (дължина без торбата за събиране на трева)
 [27] Ширина
 [28] Ширина с дефлектор на страничното разтоварване (Ширина без дефлектор на страничното разтоварване)
 [29] Височина
 [30] Код на инструмента за рязане
 [31] Ниво на звуково налягане
 [32] Несигурност на измерване
 [33] Измерено ниво на акустична мощност
 [34] Гарантирано ниво на акустична мощност
 [35] Ниво на вибрации в мястото за управление
 [36] Ниво на вибрации на волана
 [49] принадлежности по поръчка
 [49.A1, 49.A2] Набор за "mulching"
 [49.B1] бързо зарядно устройство - щепсел за ЕС
 [49.B2] бързо зарядно устройство - щепсел за Великобритания
 [49.C] Набор за теглене
 [49.D] Покривен брезент
 [49.E] Набор защита на задно разтоварване (само за модели от серията MP)
 [49.F] Вериги за сняг
 [49.G] Колела за кал / сняг
 [49.H] Ремарке
 [49.I] Приспособление за разсейване на пясък или чакъл
 [49.J] Снегорин с острие
 [43] допълнителен контакт за usb аксесоари
 [43.A] Напрежение и ток на зареждане (На изход USB)
 [43.B] Вид
 [43.C] Наименование и адрес на производителя

* За специфични данни, вижте посоченото на идентификационния етикет на машината

** Вижте налягането, посочено на гумите

[1] BS - TEHNIČKI PODACI

- [2] Napon napajanja MAX
 [3] Napon napajanja NOMINAL
 [4] Maks. brzina rada motora
 [5] Baterija (napomena: nije opremljen baterijom)
 [6] Kapacitet baterije
 [7] Punjač baterije
 [8.1] Maksimalno trajanje napunjene baterije (jedna baterija)
 [8.2] Maksimalno trajanje napunjene baterije (dvije baterije)
 [9] Snaga pogonskog motora
 [10] Snaga motora sječiva
 [11] Frekvencijski pojas (frekvencijski pojasi) u kojem (u kojima) radijska oprema radi
 [12] Najveća radiofrekvencijska snaga koja se prenosi u frekvencijskom pojasu (frekvencijskim pojasi) u kojem (u kojima) radijska oprema radi
 [13] Prednje gume
 [14] Zadnje gume
 [15] Pritisak vazduha u prednjim gumama
 [16] Pritisak vazduha u zadnjim gumama
 [17] Masa (bez baterije*)
 [18] Minimalan radijus nepokošene trave
 [19] Visina košenja
 [20] Širina košenja
 [21] Brzina kretanja (indikativna), naprijed
 [22] Brzina kretanja (indikativna), u rikverc
 [23] Maksimalno dozvoljen nagib
 [24] Dimenzije
 [25] Dužina
 [26] Dužina s vrećom (dužina bez vreće)
 [27] Širina
 [28] Širina s usmjerivačem bočnog izbacivanja (Širina bez usmjerivača bočnog izbacivanja)
 [29] Visina
 [30] Šifra rezne glave
 [31] Razina zvučnog pritiska
 [32] Mjerna nesigurnost
 [33] Izmjerena razina zvučne snage
 [34] Garantirana razina zvučne snage
 [35] Razina vibracija na mjestu vozača
 [36] Razina vibracija na volanu
 [49] Dodatna oprema na zahtjev
 [49.A1, 49.A2] Komplet za malčiranje
 [49.B1] Brzi punjač baterija - EU utikač
 [49.B2] Brzi punjač baterija - UK utikač
 [49.C] Komplet za vuču
 [49.D] Pokrovna cerada
 [49.E] Komplet štitnika za izbacivanje odotraga (samo za seriju modela MP)
 [49.F] Lanci za snijeg
 [49.G] Točkovi za blato / snijeg
 [49.H] Prikolica
 [49.I] Rasipač
 [49.J] Plug za snijeg s nožem
 [43] Pomoćna utičnica za dodatni pribor usb
 [43.A] Napon i struja punjenja (izlaz USB)
 [43.B] Tip
 [43.C] Naziv i adresa proizvođača

* Za specifični podatak, pogledajte što je navedeno na identifikacijskoj naljepnici mašine

** Pogledajte pritisak naveden na gumama

[1] CS - TECHNICKÉ PARAMETRY

- [2] Napájecí napětí MAX
 [3] Napájecí napětí NOMINAL
 [4] Maximální rychlost činnosti motoru
 [5] Akumulátor (Poznámka: Není vybaven baterií)
 [5a] Lithium-iontový akumulátor (Li-Ion)
 [6] Kapacita akumulátoru
 [7] Nabíječka akumulátoru
 [8.1] Maximální výdrž nabití (jedna baterie)
 [8.2] Maximální výdrž nabití (dvě baterie)
 [9] Výkon motoru pohonu
 [10] Výkon motoru nožů
 [11] Kmitočtové pásmo (kmitočtová pásma), v němž (v nichž) rádiové zařízení pracuje
 [12] Maximální radiofrekvenční výkon vysílaný v kmitočtovém pásmu (v kmitočtových pásmech), v němž (v nichž) je rádiové zařízení provozováno
 [13] Přední pneumatiky
 [14] Zadní pneumatiky
 [15] Tlak huštění předních pneumatik
 [16] Tlak huštění zadních pneumatik
 [17] Hmotnost (bez baterie*)
 [18] Minimální poloměr neposečené trávy
 [19] Výška sekání
 [20] Šířka sekání
 [21] Rychlost postupu (indikativní) při postupu napřed
 [22] Rychlost postupu (indikativní) při couvání
 [23] Maximální povolené naklonění
 [24] Rozměry
 [25] Délka
 [26] Délka s košem (Délka bez koše)
 [27] Šířka
 [28] Šířka vychylovače bočního výhozu (Šířka bez vychylovače bočního výhozu)
 [29] Výška
 [30] Kód sekacího zařízení
 [31] Úroveň akustického tlaku
 [32] Nepřesnost měření
 [33] Úroveň naměřeného akustického výkonu
 [34] Úroveň zaručeného akustického výkonu
 [35] Úroveň vibrací na místě řidiče
 [36] Úroveň vibrací na volantu
 [49] Přisloušenství na požádání
 [49.A1, 49.A2] Sada pro mulčování
 [49.B1] Rychlá nabíječka baterií - Zástrčka EU
 [49.B2] Rychlá nabíječka baterií - Zástrčka pro Spojené království
 [49.C] Sada tažného zařízení
 [49.D] Krycí plachta
 [49.E] Sada ochranného krytu zadního výhozu
(jen pro modely řady MP)
 [49.F] Sněhové řetězy
 [49.G] Kola do bláta / sněhu
 [49.H] Přívěs
 [49.I] Posypávač
 [49.J] Sněhová radlice
 [43] POMOČNÁ ZÁSUVKA PRO USB PŘISLUŠENSTVÍ
 [43.A] Nabíjecí napětí a proud (výstup USB)
 [43.B] Typ
 [43.C] Název a adresa Výrobce

* Ohledně uvedeného údaje vycházejte z hodnoty uvedené na identifikačním štítku stroje.

** Viz tlak uvedený na pneumatikách.

[1] DA - TEKNISKE DATA

- [2] Forsyningsspænding MAX
 [3] Forsyningsspænding NOMINAL
 [4] Motorens maks. driftshastighed
 [5] Batteri (Bemærk: Ikke udstyret med batteri)
 [5a] Litiunion (Li-on)
 [6] Batterikapacitet
 [7] Batterioplader
 [8.1] Maksimal varighed af opladning (et batteri)
 [8.2] Maksimal varighed af opladning (to batterier)
 [9] Trækmotoreffekt
 [10] Klingemotoreffekt
 [11] Frekvensbånd, som radioudstyret fungerer på
 [12] Maksimal radiofrekvenseffekt, der udsendes i det frekvensbånd, som radioudstyret fungerer på.
 [13] Forhjulsdæk
 [14] Baghjulsdæk
 [15] Pumpetryk for for-dæk
 [16] Pumpetryk for bagdæk
 [17] Vægt (uden batteri*)
 [18] Minimumsradius af ikke klippet græs
 [19] Klippehøjde
 [20] Klippebredde
 [21] Fremføringshastighed (vejledende), i fremgear
 [22] Fremføringshastighed (vejledende), i baggear
 [23] Maksimal tiladt højdning
 [24] Mål
 [25] Længde
 [26] Længde med opsamlingspose
 (længde uden pose)
 [27] Bredde
 [28] Bredde med sideudkast skærm (Hvis monteret)
 [29] Højde
 [30] Skæreanordningens varenr.
 [31] Lydtryksniveau
 [32] Målesikkerhed
 [33] Målt lyddefektniveau
 [34] Garanteret lyddefektniveau
 [35] Vibrationsniveau på førersædet
 [36] Vibrationsniveau ved rattet
 [49] Ekstraudstyr
 [49.A1, 49.A2] Sæt til "Multiclip"
 [49.B1] Hurtig batterioplader - EU-stik
 [49.B2] Hurtig batterioplader - UK-stik
 [49.C] Sæt til bugsering
 [49.D] Presenning
 [49.E] Sæt til beskyttelse på bagudkast (*bare for MP serie modeller*)
 [49.F] Snekedder
 [49.G] Mudder- og snehjul
 [49.H] Anhænger
 [49.I] Fordeler
 [49.J] Sneplow med skrabskær
 [43] STIKKONTAKT TIL EKSTRA USB-UDSTYR
 [43.A] Spænding og opladningsstrøm (udgang USB)
 [43.B] Type
 [43.C] Fabrikantens navn og adresse

* For disse data henvises til hvad der er angivet på maskinens identifikationsmærkat.

** Se trykket, der vises på dækkene.

<p>[1] DE - TECHNISCHE DATEN</p> <p>[2] Versorgungsspannung MAX</p> <p>[3] Versorgungsspannung NOMINAL</p> <p>[4] Max. Betriebsgeschwindigkeit des Motors</p> <p>[5] Batterie (hinweis: nicht mit Batterie ausgestattet)</p> <p>[5a] Lithiumion (Li-on)</p> <p>[6] Batteriekapazität</p> <p>[7] Batterieladegerät</p> <p>[8.1] Maximale Dauer der Ladung (ein batterie)</p> <p>[8.2] Maximale Dauer der Ladung (zwei batterien)</p> <p>[9] Antriebsmotor-Leistung</p> <p>[10] Messermotor-Leistung</p> <p>[11] Frequenzbänder, auf denen die Funkanlage arbeitet</p> <p>[12] Maximale übertragene Funkfrequenzleistung in den Frequenzbändern, auf denen die Funkanlage arbeitet</p> <p>[13] Reifen Vorderräder</p> <p>[14] Reifen Hinterräder</p> <p>[15] Reifendruck vorne</p> <p>[16] Reifendruck hinten</p> <p>[17] Gewicht (ohne Batterie*)</p> <p>[18] Mindestradius nicht geschnittenes Gras</p> <p>[19] Schnitthöhe</p> <p>[20] Schnittbreite</p> <p>[21] Fahrgeschwindigkeit (ca.), vorwärts</p> <p>[22] Fahrgeschwindigkeit (ca.), rückwärts</p> <p>[23] Max. zulässige Neigung</p> <p>[24] Abmessungen</p> <p>[25] Länge</p> <p>[26] Länge mit Grasfangeinrichtung (Länge ohne Grasfangeinrichtung)</p> <p>[27] Breite</p> <p>[28] Breite mit seitlichem Auswurfdeflektor (Breite ohne seitlichen Auswurfdeflektor)</p> <p>[29] Höhe</p> <p>[30] Code Schneidwerkzeug</p> <p>[31] Schalldruckpegel</p> <p>[32] Messungengenauigkeit</p> <p>[33] Gemessener Schalleistungspegel</p> <p>[34] Garantierter Schalleistungspegel</p> <p>[35] Vibrationspegel am Fahrersitz</p> <p>[36] Vibrationspegel am Lenkrad</p> <p>[49] Sonderzubehör</p> <p>[49.A1, 49.A2] "Mulching"-kit</p> <p>[49.B1] Schnellladegerät - EU-Stecker</p> <p>[49.B2] Schnellladegerät - UK-Stecker</p> <p>[49.C] Zugvorrichtung</p> <p>[49.D] Abdeckung</p> <p>[49.E] Kit hinterer auswurfschutz (<i>nur für MP-Series</i>)</p> <p>[49.F] Schneeketten</p> <p>[49.G] M+S-Räder (Matsch- und Schneeräder)</p> <p>[49.H] Anhänger</p> <p>[49.I] Streuer</p> <p>[49.J] Schneepflug</p> <p>[43] USB-ZUBEHÖRSTECKDOSE</p> <p>[43.A] Ladespannung und -strom (Ausgang USB)</p> <p>[43.B] Typ</p> <p>[43.C] Name und Anschrift des Herstellers</p>	<p>[1] EL - ΤΕΧΝΙΚΑ ΧΑΡΑΚΤΗΡΙΣΤΙΚΑ</p> <p>[2] Τάση τροφοδοσίας MAX</p> <p>[3] Τάση τροφοδοσίας NOMINAL</p> <p>[4] Μέγ. ταχύτητα λειτουργίας κινητήρα</p> <p>[5] Μπαταρία (σημείωση: δεν είναι εξοπλισμένο με μπαταρία)</p> <p>[6] Χωρητικότητα μπαταρίας</p> <p>[7] Φορτιστής Μπαταρίας</p> <p>[8.1] Μέγιστη διάρκεια φόρτισης (μία μπαταρία)</p> <p>[8.2] Μέγιστη διάρκεια φόρτισης (δύο μπαταρίες)</p> <p>[9] Ισχύς κινητήρα κίνησης στους τροχούς</p> <p>[10] Ισχύς κινητήρα δίσκων</p> <p>[11] Μπάντες συχνότητας λειτουργίας του ραδιοεξοπλισμού</p> <p>[12] Μέγιστη ισχύ ραδιοσυχνότητας ανάμεσα στις μπάντες συχνότητας στις οποίες λειτουργεί ο ραδιοεξοπλισμός.</p> <p>[13] Εμπρόσθια ελαστικά</p> <p>[14] Πίσω ελαστικά</p> <p>[15] Πίεση εμπρόσθιων ελαστικών</p> <p>[16] Πίεση πίσω ελαστικών</p> <p>[17] Βάρος (χωρίς μπαταρία)*</p> <p>[18] Ελάχιστη ακτίνα μη κομμένου χόρτου</p> <p>[19] Ύψος κοπής</p> <p>[20] Πλάτος κοπής</p> <p>[21] Ταχύτητα κίνησης (ενδεικτική), στην κίνηση εμπρός</p> <p>[22] Ταχύτητα κίνησης (ενδεικτική), στην κίνηση πίσω</p> <p>[23] Μέγιστη επιτρεπόμενη γωνία</p> <p>[24] Διαστάσεις</p> <p>[25] Μήκος</p> <p>[26] Μήκος με κάδο (μήκος χωρίς κάδο)</p> <p>[27] Πλάτος</p> <p>[28] Πλάτος με πλευρικό εκτροπέα αποβολής (Πλάτος χωρίς πλευρικό εκτροπέα αποβολής)</p> <p>[29] Ύψος</p> <p>[30] Κωδικός συστήματος κοπής</p> <p>[31] Στάθμη ακουστικής πίεσης</p> <p>[32] Αβεβαιότητα μέτρησης</p> <p>[33] Μετρημένη στάθμη ακουστικής ισχύος</p> <p>[34] Εγγυημένη στάθμη ακουστικής ισχύος</p> <p>[35] Επίπεδο κραδασμών στη θέση του οδηγού</p> <p>[36] Επίπεδο κραδασμών στο τιμόνι</p> <p>[49] αιτούμενα παρελκόμενα</p> <p>[49.A1, 49.A2] Σετ "mulching"</p> <p>[49.B1] γρήγορος φορτιστής μπαταρίας – βύσμα EU</p> <p>[49.B2] γρήγορος φορτιστής μπαταρίας – βύσμα Ηνωμένου Βασιλείου</p> <p>[49.C] Σετ ρυμούλκησης</p> <p>[49.D] Κάλυμμα προστασίας</p> <p>[49.E] Σετ προστασίας οπισθίας αποβολής (μόνο για τα μοντέλα της σειράς MP)</p> <p>[49.F] Αλυσίδες χιονιού</p> <p>[49.G] Τροχοί για λάσπη / χιόνι</p> <p>[49.H] Ρυμούλκουμενο</p> <p>[49.I] Διανομέας</p> <p>[49.J] Εκχιονιστικό με λάμα</p> <p>[43] ΒΟΗΘΗΤΙΚΗ ΠΡΙΖΑ ΓΙΑ ΑΞΕΣΟΥΡ USB</p> <p>[43.A] Τάση και ρεύμα φόρτισης (Έξοδος USB)</p> <p>[43.B] Τύπος</p> <p>[43.C] Ονομα και διεύθυνση του Κατασκευαστή</p>
<p>* Für die genaue Angabe nehmen Sie bitte auf das Typenschild der Maschine Bezug.</p> <p>** Siehe den angegebenen Druck auf den Reifen.</p>	<p>* Για το συγκεκριμένο στοιχείο, ελέγξτε τα όσα αναγράφονται στην ετικέτα προσδιορισμού του μηχανήματος</p> <p>** Δείτε την πίεση που αναγράφεται στα ελαστικά.</p>

<p>[1] EN - TECHNICAL DATA</p> <p>[2] Power supply voltage MAX</p> <p>[3] Power supply voltage NOMINAL</p> <p>[4] Max. motor operating speed</p> <p>[5] Battery (note: not equipped with battery)</p> <p>[5a] With Lithium ions (Li-on)</p> <p>[6] Battery capacity</p> <p>[7] Battery charger</p> <p>[8.1] Maximum charge duration (one battery)</p> <p>[8.2] Maximum charge duration (two batteries)</p> <p>[9] Traction motor power</p> <p>[10] Blade motor power</p> <p>[11] Frequency band(s) in which the radio equipment operates</p> <p>[12] Maximum radio-frequency power transmitted in the frequency band(s) in which the radio equipment operates</p> <p>[13] Front tyres</p> <p>[14] Rear tyres</p> <p>[15] Front tyre pressure</p> <p>[16] Rear tyre pressure</p> <p>[17] Mass (without battery*)</p> <p>[18] Minimum radius of uncut grass</p> <p>[19] Cutting height</p> <p>[20] Cutting width</p> <p>[21] Forward travel speed (indicative)</p> <p>[22] Reverse travel speed (indicative)</p> <p>[23] Maximum admissible tilt</p> <p>[24] Dimensions</p> <p>[25] Length</p> <p>[26] Length with grass catcher (length without grass catcher)</p> <p>[27] Width</p> <p>[28] Width with side discharge chute (Width without side discharge chute)</p> <p>[29] Height</p> <p>[30] Cutting means code</p> <p>[31] Sound pressure level</p> <p>[32] Measurement uncertainty</p> <p>[33] Measured sound power level</p> <p>[34] Guaranteed sound power level</p> <p>[35] Operator position vibration level</p> <p>[36] Steering wheel vibration level</p> <p>[49] Accessories available on request</p> <p>[49.A1, 49.A2] "Mulching" kit</p> <p>[49.B1] Fast battery charger - EU plug</p> <p>[49.B2] Fast battery charger - UK plug</p> <p>[49.C] Towing kit</p> <p>[49.D] Cloth cover</p> <p>[49.E] Rear discharge guard kit (<i>only for MP series</i>)</p> <p>[49.F] Snow chains</p> <p>[49.G] Mud / Snow wheels</p> <p>[49.H] Trailer</p> <p>[49.I] Sprinkler</p> <p>[49.J] Snow shovel</p> <p>[43] AUXILIARY PORT FOR USB ACCESSORIES</p> <p>[43.A] Charging voltage and current (Output USB)</p> <p>[43.B] Type</p> <p>[43.C] Name and address of Manufacturer</p> <p>* Please refer to the data indicated on the machine's identification plate for the exact figure.</p> <p>**See the pressure indicated on the tyres.</p>	<p>[1] ES - DATOS TÉCNICOS</p> <p>[2] Tensión de alimentación MAX</p> <p>[3] Tensión de alimentación NOMINAL</p> <p>[4] Velocidad máx. de funcionamiento motor</p> <p>[5] Batería (nota: no equipado con batería)</p> <p>[5a] De iones de litio (Li-on)</p> <p>[6] Capacidad de la batería</p> <p>[7] Cargador de batería</p> <p>[8.1] Máxima duración de la carga (una batería)</p> <p>[8.2] Máxima duración de la carga (dos baterías)</p> <p>[9] Potencia del motor de tracción</p> <p>[10] Potencia del motor de cuchillas</p> <p>[11] Banda o bandas de frecuencia en las que opera el equipo radioeléctrico</p> <p>[12] Potencia máxima de radiofrecuencia transmitida en la banda o bandas de frecuencia en las que opera el equipo radioeléctrico</p> <p>[13] Neumáticos anteriores</p> <p>[14] Neumáticos posteriores</p> <p>[15] Presión neumático anterior</p> <p>[16] Presión neumático posterior</p> <p>[17] Masa (sin batería*)</p> <p>[18] Radio mínimo de hierba no cortada</p> <p>[19] Altura de corte</p> <p>[20] Anchura de corte</p> <p>[21] Velocidad de avance (indicativa) con marcha adelante</p> <p>[22] Velocidad de avance (indicativa) con marcha atrás</p> <p>[23] Inclinación máxima permitida</p> <p>[24] Dimensiones</p> <p>[25] Longitud</p> <p>[26] Longitud con bolsa (longitud sin bolsa)</p> <p>[27] Anchura</p> <p>[28] Ancho con deflector de descarga lateral (ancho sin deflector de descarga lateral)</p> <p>[29] Altura</p> <p>[30] Código dispositivo de corte</p> <p>[31] Nivel de presión acústica</p> <p>[32] Incertidumbre de medida</p> <p>[33] Nivel de potencia acústica medido</p> <p>[34] Nivel de potencia acústica garantizado</p> <p>[35] Nivel de vibraciones en el puesto de conductor</p> <p>[36] Nivel de vibraciones al volante</p> <p>[49] Accesorios bajo pedido</p> <p>[49.A1, 49.A2] Kit para "mulching"</p> <p>[49.B1] Cargador de batería rápido - enchufe EU</p> <p>[49.B2] Cargador de batería rápido - enchufe UK</p> <p>[49.C] Kit remolque</p> <p>[49.D] Lona de cubierta</p> <p>[49.E] Kit sistema de seguridad de descarga posterior (<i>sólo para la serie MP</i>)</p> <p>[49.F] Cadenas de nieve</p> <p>[49.G] Ruedas para fango y nieve</p> <p>[49.H] Remolque</p> <p>[49.I] Esparcidor</p> <p>[49.J] Quitanieves de cuchilla</p> <p>[43] Toma auxiliar para accesorios usb</p> <p>[43.A] Tensión y corriente de carga (Salida USB)</p> <p>[43.B] Tipo</p> <p>[43.C] Nombre y dirección del Fabricante</p> <p>* Para el dato específico, hacer referencia a lo indicado en la etiqueta de identificación de la máquina.</p> <p>** Ver la presión indicada en los neumáticos.</p>
---	---

[1] ET - TEHNILISED ANDMED

- [2] Toite pingeline MAX
 [3] Toite pingeline NOMINAL
 [4] Mootori töötamise maks. kiirus
 [5] Aku (märkus: ei ole akuga varustatud)
 [5a] Liitiumioon (Li-ion)
 [6] Aku võimsus
 [7] Akulaadija
 [8.1] Maksimumlaengu kestus (üks aku)
 [8.2] Maksimumlaengu kestus (kaks akut)
 [9] Veomootori võimsus
 [10] Sahamootori võimsus
 [11] Sagedusriba(d), millele raadioseade töötab
 [12] Raadioseadme töösagedus(t)el edastatav maksimaalne saatevõimsus.
 [13] Eesmised rehvid
 [14] Tagumised rehvid
 [15] Pumpamise rõhk ees
 [16] Pumpamise rõhk taga
 [17] Mass (ilma akuta*)
 [18] Lõikamata rohu minimaalne raadius
 [19] Lõikekõrgus
 [20] Lõikelaius
 [21] Liikumiskiirus (indikatiivne), edasikäigul
 [22] Liikumiskiirus (indikatiivne), tagasikäigul
 [23] Suurim lubatud kalle
 [24] Mõõtmised
 [25] Pikkus
 [26] Pikkus korviga (pikkus ilma korvita)
 [27] Laius
 [28] Laius koos külgväljaviske deflektoriga (Laius ilma külgväljaviske deflektorita)
 [29] Kõrgus
 [30] Lõikeseadme kood
 [31] Helirõhu tase
 [32] Mõõtemääramatus
 [33] Mõõdetud müravõimsuse tase
 [34] Garanteeritud müravõimsuse tase
 [35] Vibratsioonitase juhiistmel
 [36] Vibratsioonide tase roolis

- [49] Tellimisel lisatarvikud
 [49.A1, 49.A2] „Multisimis“ komplekt
 [49.B1] Kiire akulaadija – EL pistik
 [49.B2] Kiire akulaadija – Ühendkuningriigi pistik
 [49.C] Järeelhaagise vedamise komplekt
 [49.D] Katterie
 [49.E] Tagumise väljaviske kaitse komplekt (ainult MP seeria)
 [49.F] Lumekehid
 [49.G] Lume- ja mudarattad
 [49.H] Järeelhaagis
 [49.I] Puistur
 [49.J] Teraga lumesahk

- [43] Lisaseadmete usb-abi pistikupesa
 [43.A] Laadimispinge ja -vool (Väljund USB)
 [43.B] tüüp
 [43.C] Tootja nimi ja aadress.

* Konkreetse info jaoks viidata masina identifitseerimisetiketile märgitule

** Vaadake rehvide peale märgitud rehvirõhku

[1] FI - TEKNISET TIEDOT

- [2] Syöttöjännite MAX
 [3] Syöttöjännite NOMINAL
 [4] Mootorin maksimaalinen toimintanopeus
 [5] Akku (huom: ei sisällä akkua)
 [5a] Litium-ioni (Li-on)
 [6] Akun kapasiteetti
 [7] Akkulaturi
 [8.1] Latauksen maksimi kesto (yksi akku)
 [8.2] Latauksen maksimi kesto (kaksi akkua)
 [9] Ajomootorin teho
 [10] Terämootorin teho
 [11] Radiotaajuudet, joilla radiolaitte toimii
 [12] Suurin mahdollinen lähetysteho radiotaajuuksilla, joilla radiolaitte toimii.
 [13] Eturenkaat
 [14] Takarenkaat
 [15] Eturenkaiden täyttöpaine
 [16] Takarenkaiden täyttöpaine
 [17] Massa (ilman akkua*)
 [18] Lõikamata rohu minimaalne raadius
 [19] Leikkukorkeus
 [20] Leikkuleveys
 [21] Etenemisnopeus (suuntaa-antava), eteenpäin mentäessä
 [22] Etenemisnopeus (suuntaa-antava), peruutettaessa
 [23] Suurin sallittu kaltevuus
 [24] Mitat
 [25] Pituus
 [26] Pituus säkin kanssa (pituus ilman säkkiä)
 [27] Leveys
 [28] Sivutyhjennyksen läppäkorkin leveys (Leveys ilman sivutyhjennyksen läppäkorkkia)
 [29] Korkeus
 [30] Leikkuvälälineen koodi
 [31] Akustisen paineen taso
 [32] Mittauksen epävarmuus
 [33] Mittattu äänitehotaso
 [34] Taattu äänitehotaso
 [35] Tärinätaaso kuljettajan paikalla
 [36] Tärinätaaso ohjauspyörässä

- [49] Tilattavat lisävarusteet
 [49.A1, 49.A2] Silppuamisvarusteet
 [49.B1] Nopea akkulaturi – EU-pistoke
 [49.B2] Nopea akkulaturi – Iso-Britannian pistoke
 [49.C] hinaussarja
 [49.D] Suojakangas
 [49.E] Takatyhjennyksen suojussarja (pelkästään MP series)
 [49.F] Lumiketjut
 [49.G] Muta-/talvipyörät
 [49.H] Perävaunu
 [49.I] Levitin
 [49.J] Lumiaura

- [43] Ylimääräinen liitin usb-lisävarusteille
 [43.A] Syöttöjännite ja -taajuus (Lähtö USB)
 [43.B] Tyyppi
 [43.C] Valmistajan nimi ja osoite

* Määrättyä arvoa varten, viittaa laitteen tunnuslaatassa annettuihin tietoihin.

** Katso renkaisiin merkitty paine.

[1] FR - CARACTÉRISTIQUES TECHNIQUES

- [2] Tension d'alimentation MAX
[3] Tension d'alimentation" NOMINAL
[4] Vitesse max. de fonctionnement du moteur
[5] Batterie (remarque : non équipé de batterie)
[5a] Lithium-ions (Li-on)
[6] Capacité de la batterie
[7] Chargeur de batterie
[8.1] Durée maximale de la charge (une batterie)
[8.2] Durée maximale de la charge (deux batteries)
[9] Puissance du moteur de traction
[10] Puissance du moteur des lames
[11] Bandes de fréquences utilisées par l'équipement radioélectrique
[12] Puissance de radiofréquence maximale transmise sur les bandes de fréquences utilisées par l'équipement radioélectrique.
[13] Pneus avant
[14] Pneus arrière
[15] Pression de gonflage avant
[16] Pression de gonflage arrière
[17] Masse (sans batterie*)
[18] Rayon minimal de l'herbe non taillée
[19] Hauteur de coupe
[20] Largeur de coupe
[21] Vitesses d'avancement (indicative), en marche avant
[22] Vitesse d'avancement (indicative), en marche arrière
[23] Pente maximale admise
[24] Dimensions
[25] Longueur
[26] Longueur avec sac (longueur sans sac)
[27] Largeur
[28] Largeur avec déflecteur d'éjection latérale (Largeur sans déflecteur d'éjection latérale)
[29] Hauteur
[30] Code organe de coupe
[31] Niveau de pression acoustique
[32] Incertitude de mesure
[33] Niveau de puissance acoustique mesuré
[34] Niveau de puissance acoustique garanti
[35] Niveau de vibration au poste de conduite
[36] Niveau de vibration au volant

[49] Accessoires sur demande
[49.A1, 49.A2] Kit pour "mulching"
[49.B1] Chargeur de batterie rapide - prise européenne
[49.B2] Chargeur de batterie rapide - prise britannique
[49.C] Kit remorquage
[49.D] Housse de protection
[49.E] Kit protecteur d'éjection arrière (seule ment pour la série MP)
[49.F] Chaîne à neige
[49.G] Roues complètes boue / neige
[49.H] Remorque
[49.I] Épandeur
[49.J] Lame à neige

[43] Prise auxiliaire pour accessoires usb
[43.A] Tension et courant de charge (Sortie USB)
[43.B] Type
[43.C] Nom et adresse du Fabricant

* Pour la valeur spécifique, se référer à ce qui est indiqué sur la plaque signalétique de la machine.

** Voir la pression indiquée sur les pneus.

[1] HR - TEHNIČKI PODACI

- [2] Napon napajanja MAX
[3] Napon napajanja NOMINAL
[4] Maks. brzina rada motora
[5] Baterija (Napomena: Ne dolazi s baterijom)
[5a] Litij-ionska baterija (Li-on)
[6] Kapacitet baterije
[7] Punjač baterija
[8.1] Maksimalno trajanje punjenja (jedna baterija)
[8.2] Maksimalno trajanje punjenja (dvije baterije)
[9] Snaga pogonskog motora
[10] Snaga motora noževa
[11] Frekvencijski pojas (frekvencijski pojasi) u kojem (kojima) radijska oprema radi;
[12] Najveća radiofrekvencijska snaga koja se prenosi u frekvencijskom pojasu (frekvencijskim pojasi) u kojem (kojima) radijska oprema radi.
[13] Prednje gume
[14] Stražnje gume
[15] Tlak zraka u prednjim gumama
[16] Tlak zraka u stražnjim gumama
[17] Masa (bez baterije*)
[18] Minimalni promjer nepokošene trave
[19] Visina košnje
[20] Širina košnje
[21] Brzina hoda (indikativna) prema naprijed
[22] Brzina hoda (indikativna) prema nazad
[23] Maksimalni dozvoljen nagib
[24] Dimenzije
[25] Dužina
[26] Dužina s košarom (dužina bez košare)
[27] Širina
[28] Širina s usmjerivačem za bočno izbacivanje (Širina bez usmjerivača za bočno izbacivanje)
[29] Visina
[30] Šifra noža
[31] Razina zvučnog tlaka
[32] Mjerna nesigurnost
[33] Izmjerena razina zvučne snage
[34] Zajamčena razina zvučne snage
[35] Razina vibracija na vozačkom mjestu
[36] Razina vibracija na upravljaču

[49] Dodatni pribor na upit
[49.A1, 49.A2] Komplet za "malčiranje"
[49.B1] Brzi punjač baterija – EU utikač
[49.B2] Brzi punjač baterija – utikač za UK
[49.C] Komplet za vuču
[49.D] Zaštitna cerada
[49.E] Komplet za štitnik stražnjeg otvora za izbacivanje (samo za MP serije)
[49.F] Lanci za snijeg
[49.G] Kotači za blato/snijeg
[49.H] Prikolica
[49.I] Rasipač
[49.J] Nož za čišćenje snijega

[43] POMOĆNA UTIČNICA ZA DODATNU OPREMU USB
[43.A] Napon i struja punjenja (Izlaz USB)
[43.B] Tip
[43.C] Naziv i adresa proizvođača

* Specifični podatak pogledajte na identifikacijskoj etiketi stroja.

**Pogledajte tlak naznačen na gumama.

<p>[1] HU - MŰSZAKI ADATOK</p> <p>[2] Tápfeszültség MAX</p> <p>[3] Tápfeszültség NOMINAL</p> <p>[4] A motor max. üzemi sebessége</p> <p>[5] Akkumulátor (Megjegyzés: Akkumulátor nélkül érkezik)</p> <p>[5a] Liúium ion (Li-on)</p> <p>[6] Az akkumulátor kapacitása</p> <p>[7] Akkumulátortöltő</p> <p>[8.1] A töltés maximális időtartama (egy akkumulátor)</p> <p>[8.2] A töltés maximális időtartama (két akkumulátor)</p> <p>[9] Hajtómotor teljesítménye</p> <p>[10] Pengemotor teljesítmény</p> <p>[11] Az(ok) a frekvenciasáv(ok), amely(ek)en a rádióberendezés működik</p> <p>[12] Az abban a frekvenciasávban vagy azokban a frekvenciasávokban továbbított maximális jelerősség, amely(ek)ben a rádióberendezés üzemel.</p> <p>[13] Elülső gumiabroncsok</p> <p>[14] Hátsó gumiabroncsok</p> <p>[15] Elülső abroncsok légnyomása</p> <p>[16] Hátsó abroncsok légnyomása</p> <p>[17] Tömeg (akkumulátor nélkül*)</p> <p>[18] Nem levágott fű minimális sugara</p> <p>[19] Nyírási magasság</p> <p>[20] Munkaszélesség</p> <p>[21] Haladási sebesség (hozzávetőleges) előremenetben</p> <p>[22] Haladási sebesség (hozzávetőleges) hátramenetben</p> <p>[23] Megegedett legnagyobb dőlés</p> <p>[24] Méretek</p> <p>[25] Hosszúság</p> <p>[26] Hosszúság szákkal (hosszúság zsák nélkül)</p> <p>[27] Szélesség</p> <p>[28] Szélesség oldalsó kidobás deflektorral (Szélesség oldalsó kidobás deflektor nélkül)</p> <p>[29] Magasság</p> <p>[30] Vágóegység kódszáma</p> <p>[31] Hangnyomásszint</p> <p>[32] Mérési bizonytalanság</p> <p>[33] Mért zajteljesítmény szint.</p> <p>[34] Garantált zajteljesítmény szint</p> <p>[35] A vezetőállásnál mért vibrációs szint</p> <p>[36] A kormánynál mért vibrációs szint</p> <p>[49] Rendelhető tartozékok</p> <p>[49.A1, 49.A2] "Mulcsoszó készlet"</p> <p>[49.B1] Gyors akkumulátortöltő - EU csatlakozó</p> <p>[49.B2] Gyors akkumulátortöltő - brit csatlakozóval</p> <p>[49.C] Vontató készlet</p> <p>[49.D] Takaró ponyva</p> <p>[49.E] Hátsó kidobás védőrész készlet (csak az MP sorozat)</p> <p>[49.F] Hóláncok</p> <p>[49.G] Sár- és hókerekek</p> <p>[49.H] Utánfutó</p> <p>[49.I] Szóró</p> <p>[49.J] Hótolólap</p> <p>[43] KIEGÉSZÍTŐ CSATLAKOZÓ USB TARTOZÉKOKHOZ</p> <p>[43.A] Töltő feszültség és áram (kimenet USB)</p> <p>[43.B] típusa</p> <p>[43.C] A gyártó neve és címe</p>	<p>[1] LT - TECHININIAI DUOMENYS</p> <p>[2] Maitinimo įtampa MAX</p> <p>[3] Maitinimo įtampa NOMINAL</p> <p>[4] Maksimalus variklio veikimo greitis</p> <p>[5] Akumuliatorius (pastaba: komplekte nėra akumuliatoriaus)</p> <p>[5a] Ličio jonų (Li-on)</p> <p>[6] Akumuliatoriaus talpa</p> <p>[7] Akumuliatoriaus įkroviklis</p> <p>[8.1] Didžiausia įkrovimo trukmė (viena baterija)</p> <p>[8.2] Didžiausia įkrovimo trukmė (dvi baterijos)</p> <p>[9] Traukos variklio galia</p> <p>[10] Ašmenų variklio galia</p> <p>[11] Dažnių juosta (-os), kurioje (-iose) veikia radijo įrenginiai</p> <p>[12] Didžiausia radijo dažnių galia, perduodama toje (tose) dažnių juostoje (-ose), kurioje (-iose) veikia radijo įrenginiai</p> <p>[13] Priekinės padangos</p> <p>[14] Užpakalinės padangos</p> <p>[15] Priekinių padangų oro slėgis</p> <p>[16] Užpakalinių padangų oro slėgis</p> <p>[17] Svoris (be akumuliatoriaus*)</p> <p>[18] Mažiausias nenupujautas žolės spindulys</p> <p>[19] Pjovimo aukštis</p> <p>[20] Pjovimo plotis</p> <p>[21] Važiavimo greitis (apytikris), priekine eiga</p> <p>[22] Važiavimo greitis (apytikris), atbuline eiga</p> <p>[23] Maksimalus leistinas pokrypis</p> <p>[24] Matmenys</p> <p>[25] Ilgis</p> <p>[26] Ilgis su maišu (ilgis be maišo)</p> <p>[27] Plotis</p> <p>[26] Plotis su šoninio išmetimo deflektoriumi (Plotis be šoninio išmetimo deflektoriaus)</p> <p>[28] Aukštis</p> <p>[29] Pjovimo įtaiso kodas</p> <p>[30] Garso slėgio lygis</p> <p>[31] Matavimo paklaida</p> <p>[32] Išmatuotas garso galios lygis</p> <p>[33] Garantuotas garso galios lygis</p> <p>[35] Vibracijų lygis, sėdynė</p> <p>[36] Vibracijų lygis, vairs</p> <p>[49] Priedai, kuriuos galima užsisakyti</p> <p>[49.A1, 49.A2] Rinkinys mulčiavimui</p> <p>[49.B1] Greitas akumuliatoriaus įkroviklis – ES kištukas</p> <p>[49.B2] Greitas akumuliatoriaus įkroviklis – JK kištukas</p> <p>[49.C] Rinkinys vilkimui</p> <p>[49.D] Apdangalas</p> <p>[49.E] Galinio išmetimo apsaugos įtaiso rinkinys (<i>tikai MP sėrija</i>)</p> <p>[49.F] Sniego grandinės</p> <p>[49.G] Ratai purvui / sniegui</p> <p>[49.H] Priekaba</p> <p>[49.I] Barstytuvas</p> <p>[49.J] Peilinis sniego valytuvas</p> <p>[43] PAGALBINIS LIZDAS USB PRIEDAMS</p> <p>[43.A] Įkrovos įtampa ir srovė (išėjimas USB)</p> <p>[43.B] tipas</p> <p>[43.C] Gamintojo adresas ir pavadinimas</p>
<p>* A pontos adatot lásd a gép azonosító adattábláján.</p> <p>** Lásd a gumiabroncsokon jelzett nyomást.</p>	<p>* Konkretūs specifiniai duomenys yra pateikti įrenginio identifikavimo etiketėje</p> <p>** Žiūrėkite ant padangų nurodytą slėgį</p>

<p>[1] LV - TEHNISKE DATI</p> <p>[2] Barošanas spriegums MAX</p> <p>[3] Barošanas spriegums NOMINAL</p> <p>[4] Maks. dzinēja griešanās ātrums</p> <p>[5] Akumulators (piezīme: nav aprīkots ar akumulatoru)</p> <p>[5a] Litija jons (Li-on)</p> <p>[6] Akumulatora jauda</p> <p>[7] Akumulatoru lādētājs</p> <p>[8.1] Uzlādes maksimālais ilgums (viens akumulators)</p> <p>[8.2] Uzlādes maksimālais ilgums (divas baterijas)</p> <p>[9] Vilces motora jauda</p> <p>[10] Asmeņu motora jauda</p> <p>[11] Frekvenču joslas, kurās radioiekārtas darbojas</p> <p>[12] Frekvenču joslas, kurās darbojas radioiekārtas, maksimālā pārraidītā signāla jauda.</p> <p>[13] Priekšējās riepas</p> <p>[14] Aizmugurējās riepas</p> <p>[15] Priekšējo riepu spiediens</p> <p>[16] Aizmugurējo riepu spiediens</p> <p>[17] Masa (bez akumulatora*)</p> <p>[18] Minimālais nenoplautās zāles rādiuss</p> <p>[19] Pļaušanas augstums</p> <p>[20] Pļaušanas platums</p> <p>[21] Kustības ātrums (aptuvenus), uz priekšu</p> <p>[22] Kustības ātrums (aptuvenus), atpakaļgaitas</p> <p>[23] Maksimālais pieļaujamais slīpums</p> <p>[24] Izmēri</p> <p>[25] Garums</p> <p>[26] Garums ar maisu (garums bez maisa)</p> <p>[27] Platums</p> <p>[28] Platums ar sāniskās izmešanas deflektoru (Platums bez sāniskās izmešanas deflektora)</p> <p>[29] Augstums</p> <p>[30] Griežņierīces kods</p> <p>[31] Skaņas spiediena līmenis</p> <p>[32] Mērijumu kļūda</p> <p>[33] Izmērītais skaņas intensitātes līmenis</p> <p>[34] Garantētais skaņas intensitātes līmenis</p> <p>[35] Vibrāciju līmenis vadītāja vietā</p> <p>[36] Stūres vibrāciju līmenis</p> <p>[49] Piederumi pēc pieprasījuma</p> <p>[49.A1, 49.A2] Mulčēšanas komplekts</p> <p>[49.B1] Ātrs akumulatora lādētājs – ES kontaktdakša</p> <p>[49.B2] Ātrs akumulatora lādētājs – Apvienotās Karalistes kontaktdakša</p> <p>[49.C] Vilkšanas komplekts</p> <p>[49.D] Pārvalks</p> <p>[49.E] Aizmugurējās izmešanas aizsarga komplekts (tik MP serijās)</p> <p>[49.F] Sniega ķēdes</p> <p>[49.G] Dubļu/sniega riteņi</p> <p>[49.H] Piekabe</p> <p>[49.I] Izklīdētājs</p> <p>[49.J] Sniega tīrītājs ar vērstuvi</p> <p>[43] Papildu ligzda usb piederumiem</p> <p>[43.A] Uzlādes (izejas USB) spriegums un strāva</p> <p>[43.B] tips</p> <p>[43.C] Ražotāja nosaukums un adrese</p> <p>* Precīza vērtība ir norādīta mašīnas identifikācijas datu plāksnītē.</p> <p>** Skatiet spiedienu, kas norādīts uz riepām.</p>	<p>[1] MK - TEHNISKI PODATOČI</p> <p>[2] Волтажа на напојување MAX</p> <p>[3] Волтажа на напојување NOMINAL</p> <p>[4] Максимална брзина при работа на моторот</p> <p>[5] Батерија (забелешка: не е опремен со батерија)</p> <p>[6] Капацитет на батерија</p> <p>[7] Полнач за батерија</p> <p>[8.1] Максимално траење на полнењето (една батерија)</p> <p>[8.2] Максимално траење на полнењето (две батерији)</p> <p>[9] Моќност на моторот за влеча</p> <p>[10] Моќност на моторот за сечило</p> <p>[11] Појаси на работна фреквенција на радиоопрема</p> <p>[12] Максимална моќност на радиофреквенција што се пренесува во појасите за фреквенција во кои функционира радиоопремата.</p> <p>[13] Предни пневматици</p> <p>[14] Задни пневматици</p> <p>[15] Притисок за полнење напред</p> <p>[16] Притисок за полнење назад</p> <p>[17] Тежина (без батерија*)</p> <p>[18] Минимален радиус на некосена трева</p> <p>[19] Висина на косење</p> <p>[20] Ширина на косење</p> <p>[21] Брзина на движење (индикативна), напред</p> <p>[22] Брзина на движење (индикативно), назазад</p> <p>[23] Најголема вредност на наведнување</p> <p>[24] Димензии</p> <p>[25] Должина</p> <p>[26] Должина со вреќата (должина без вреќата)</p> <p>[27] Ширина</p> <p>[28] Ширина со дефлектор со страничен испуст (ширина без дефлектор со страничен испуст)</p> <p>[29] Висина</p> <p>[30] Код на уредот со сечивото</p> <p>[31] Ниво на акустичен притисок</p> <p>[32] Отстапување од мерењата</p> <p>[33] Измерено ниво на акустична моќност</p> <p>[34] Гарантирано ниво на акустична моќност</p> <p>[35] Ниво на вибрации на местото за управување</p> <p>[36] Ниво на вибрации на воланот</p> <p>[49] додатоци достапни на барање</p> <p>[49.A1, 49.A2] Комплет за „мелење“</p> <p>[49.B1] Брз полнач за батерији - приклучок од ЕУ</p> <p>[49.B2] Брз полнач за батерији - приклучок за Обединетото Кралство</p> <p>[49.C] Комплет за приколка</p> <p>[49.D] Платно за покривање</p> <p>[49.E] Комплет за заштита на страничен испуст (само за MP серија)</p> <p>[49.F] Синџири за снег</p> <p>[49.G] Гуми за кал/снег</p> <p>[49.H] Приколка</p> <p>[49.I] Дробалка</p> <p>[49.J] Сечиво за снег</p> <p>[43] ДОПОЛНИТЕЛЕН ПРИКЛУЧОК ЗА ДОДАТОЦИ СО USB</p> <p>[43.A] Волтажа и енергија за полнење (Излез USB)</p> <p>[43.B] Тип</p> <p>[43.C] Име и адреса на производителот</p> <p>* За одреден податок, проверете дали истиот е посочен на етикетата за идентификација на машината.</p> <p>** Видете го притисокот наведен на гумите</p>
---	--

[1] NL - TECHNISCHE GEGEVENS

- [2] Spanning voeding MAX
- [3] Spanning voeding NOMINAL
- [4] Maximale snelheid voor de werking van de motor
- [5] Accu (let op: niet voorzien van batterij)
- [5a] Li-ion-accu
- [6] Capaciteit accu
- [7] Acculader
- [8.1] Maximum duur lading (één batterij)
- [8.2] Maximum duur lading (twee batterijen)
- [9] Vermogen tractiemotor
- [10] Vermogen motor messen
- [11] Frequentieband(en) waarin de radioapparatuur functioneert
- [12] Maximaal radiofrequent vermogen uitgezonden in de frequentieband(en) waarin de radioapparatuur functioneert
- [13] Voorbanden
- [14] Achterbanden
- [15] Bandenspanning vooraan
- [16] Bandenspanning achteraan
- [17] Massa (zonder batterij*)
- [18] Minimum straal ongemaaid gras
- [19] Maaihoogte
- [20] Maai breedte
- [21] Rijsnelheid (bij benadering), vooruit
- [22] Rijsnelheid (bij benadering), achteruit
- [23] Maximaal toegestane helling
- [24] Afmetingen
- [25] Lengte
- [26] Lengte met zak (lengte zonder zak)
- [27] Breedte
- [28] Breedte met zijdelingse aflaafdeflector (Breedte zonder zijdelingse aflaafdeflector)
- [29] Hoogte
- [30] Code snij-inrichting
- [31] Niveau geluidsdruk
- [32] Meetonzekerheid
- [33] Gemeten akoestisch vermogen
- [34] Gewaarborgd akoestisch vermogen
- [35] Niveau trillingen op de bestuurdersplaats
- [36] Niveau trillingen aan het stuur

- [49] Optionele accessoires
- [49.A1, 49.A2] Kit voor "mulching"
- [49.B1] Snelle batterijlader – EU-stekker
- [49.B2] Snelle batterijlader – UK-stekker
- [49.C] Kit tractie
- [49.D] Afdekzeil
- [49.E] Kit achterste aflaafbeveiliging (alleen voor MP-serie)
- [49.F] Sneeuwkettingen
- [49.G] Modderwielen/sneeuwwielen
- [49.H] Aanhangwagen
- [49.I] Verspreider
- [49.J] Sneeuwschuiver

[43] AUX-AANSLUITING VOOR USB-ACCESSOIRES

- [43.A] Laadspanning en -stroom (Uitgang USB)
- [43.B] type
- [43.C] Naam en adres van de fabrikant

* Voor het specifiek gegeven, verwijst men naar wat aangegeven is op het identificatielabel van de machine.

** Zie de spanning aangegeven op de banden.

[1] NO - TEKNISKE DATA

- [2] Matespenning MAX
- [3] Matespenning NOMINAL
- [4] Motorens maks driftshastighet
- [5] Batteri (merk: ikke utstyrt med batteri)
- [5a] Med litiumion (Li-on)
- [6] Batteriets kapasitet
- [7] Batterilader
- [8.1] Maksimal varighet for ladingen (ett batteri)
- [8.2] Maksimal varighet for ladingen (to batterier)
- [9] Trekkmotorens effekt
- [10] Knivmotorens effekt
- [11] Driftsfrekvensbånd for radioutstyret
- [12] Maksimal radiofrekvenseffekt som overføres i frekvensbåndene som radioutstyret benytter.
- [13] Fordekk
- [14] Bakdekk
- [15] Lufttrykk foran
- [16] Lufttrykk bak
- [17] Vekt (uten batteri*)
- [18] Minste radius til ikke klippt gress
- [19] Klippehøyde
- [20] Klippebredde
- [21] Fremdriftshastighet (veil.) forover
- [22] Fremdriftshastighet (veil.) bakover
- [23] Maks. tillatt helling
- [24] Mål
- [25] Lengde
- [26] Lengde med oppsamler (lengde uten oppsamler)
- [27] Bredde
- [28] Bredde med deflektor for sideutkast (Bredde uten deflektor for sideutkast)
- [29] Høyde
- [30] Artikkelnnummer for klippeinnretning
- [31] Lydtrykknivå
- [32] Måleusikkerhet
- [33] Målt lydeffektnivå
- [34] Garantert lydeffektnivå
- [35] Vibrasjonsnivå ved førerplassen
- [36] Vibrasjonsnivå ved rattet

- [49] Tilleggsutstyr på forespørsel
- [49.A1, 49.A2] Mulching-sett
- [49.B1] Rask batterilader - EU-plugg
- [49.B2] Rask batterilader - UK-plugg
- [49.C] Sett med tilhengerfeste
- [49.D] Presenning
- [49.E] Sett med vern for utkast bak (MP-series)
- [49.F] Snøkjettinger
- [49.G] Gjørme-/snøhjul
- [49.H] Tilhenger
- [49.I] Spreader
- [49.J] Snøplog

[43] Ekstra uttak for usb tilbehør

- [43.A] Ladespenning og strøm (Utgang USB)
- [43.B] type
- [43.C] Produsentens navn og adresse

* For spesifikk informasjon, se referansen på maskinens identifikasjonsetikett.

** Se trykket indikert på dekkene.

[1] PL - DANE TECHNICZNE

- [2] Napięcie zasilania MAX
- [3] Napięcie zasilania NOMINAL
- [4] Maks. prędkość obrotowa silnika
- [5] Akumulator (uwaga: nie jest wyposażony w baterię)
- [5a] jonowo-litowy (Li-on)
- [6] Pojemność akumulatora
- [7] Ładowarka akumulatora
- [8.1] Maksymalny czas ładowania (jednej baterii)
- [8.2] Maksymalny czas ładowania (dwie baterie)
- [9] Moc silnika napędowego
- [10] Moc silnika ostrzy
- [11] Zakres(-y) częstotliwości, w którym (których) pracuje urządzenie radiowe;
- [12] Maksymalna moc częstotliwości radiowej emitowanej w zakresie(-ach) częstotliwości, w którym (których) pracuje urządzenie radiowe
- [13] Koła przednie
- [14] Koła tylne
- [15] Ciśnienie powietrza kół przednich
- [16] Ciśnienie powietrza kół tylnych
- [17] Masa (bez baterii*)
- [18] Minimalny promień nieskoszonej trawy
- [19] Wysokość koszenia
- [20] Szerokość koszenia
- [21] Prędkość jazdy (orientacyjnie) podczas ruchu do przodu
- [22] Prędkość jazdy (orientacyjnie) podczas ruchu do tyłu
- [23] Maksymalne dopuszczalne nachylenie
- [24] Wymiary
- [25] Długość
- [26] Długość z pojemnikiem (długość bez pojemnika)
- [27] Szerokość
- [28] Szerokość z deflektorem wyrzutu bocznego (Szerokość bez deflektora wyrzutu bocznego)
- [29] Wysokość
- [30] Kod agregatu tnącego
- [31] Poziom ciśnienia akustycznego
- [32] Błąd pomiaru
- [33] Poziom mocy akustycznej zmierzony
- [34] Gwarantowany poziom mocy akustycznej
- [35] Poziom drgań na stanowisku kierowcy
- [36] Poziom drgań na kierownicy

- [49] Akcesoria dostępne na zamówienie
- [49.A1, 49.A2] Zestaw mulczujący
- [49.B1] Szybka ładowarka baterii - wtyczka EU
- [49.B2] Szybka ładowarka baterii - wtyczka brytyjska
- [49.C] Zestaw do holowania
- [49.D] Pokrowiec
- [49.E] Zestaw osłony tylnego wyrzutu trawy (wyłącznie dla serii MP)
- [49.F] Łańcuchy przeciwnięgowe
- [49.G] Koła błotne / śnieżne
- [49.H] Przyczepa
- [49.I] Rozrzutnik
- [49.J] Piłg śnieżny

- [43] Gniazdo pomocnicze dla akcesoriów usb
- [43.A] Napięcie i prąd ładowania (Wyjście USB)
- [43.B] Typ
- [43.C] Nazwa i adres producenta

* W celu uzyskania konkretnych danych, należy się odnieść do wskazań zamieszczonych na tabliczce identyfikacyjnej maszyny.

** Patrz ciśnienie wskazane na oponach.

[1] PT - DADOS TÉCNICOS

- [2] Tensão de alimentação MAX
- [3] Tensão de alimentação NOMINAL
- [4] Velocidade máx. de funcionamento motor
- [5] Bateria (nota: não equipado com bateria)
- [5a] de íons de Lítio (Li-on)
- [6] Capacidade da bateria
- [7] Carregador de bateria
- [8.1] Máxima duração da carga (uma bateria)
- [8.2] Máxima duração da carga (duas baterias)
- [9] Potência do motor de tração
- [10] Potência do motor das lâminas
- [11] A(s) banda(s) de frequências em que o equipamento de rádio funciona
- [12] A potência máxima de radiofrequências transmitida na(s) banda(s) de frequências em que o equipamento de rádio funciona.
- [13] Pneus dianteiros
- [14] Pneus traseiros
- [15] Pressão dos pneus dianteiros
- [16] Pressão dos pneus traseiros
- [17] Massa (sem bateria*)
- [18] Raio mínimo da relva não cortada
- [19] Altura de corte
- [20] Largura de corte
- [21] Velocidade de progresso (indicativa), em marcha à frente
- [22] Velocidade de progresso (indicativa), em marcha-atrás
- [23] Inclinação máxima autorizada
- [24] Dimensões
- [25] Comprimento
- [26] Comprimento com saco (comprimento sem saco)
- [27] Largura
- [28] Largura com deflector de descarga lateral (Largura sem deflector de descarga lateral)
- [29] Altura
- [30] Código dispositivo de corte
- [31] Nível de pressão acústica
- [32] Incerteza de medição
- [33] Nível de potência acústica medido
- [34] Nível de potência acústica garantido
- [35] Nível de vibrações no local de condução
- [36] Nível de vibrações no volante

- [49] Acessórios a pedido
- [49.A1, 49.A2] Kit para "mulching"
- [49.B1] Carregador de bateria rápido - ficha UE
- [49.B2] Carregador de bateria rápido - ficha do Reino Unido
- [49.C] Kit tração
- [49.D] Lona de cobertura
- [49.E] Kit proteção de descarga traseira (apenas para série MP)
- [49.F] Correntes para neve
- [49.G] Rodas para lama / neve
- [49.H] Reboque
- [49.I] Espalhador
- [49.J] Limpa-neves com lâmina

- [43] tomada auxiliar para acessórios usb
- [43.A] Tensão e corrente de carga (Saída USB)
- [43.B] Tipo
- [43.C] Nome e endereço do Fabricante

* Para o dado específico, consulte a etiqueta de identificação da máquina.

** Veja a pressão indicada nos pneus.

<p>[1] RO - DATE TEHNICE</p> <p>[2] Tensiunea de alimentare MAX</p> <p>[3] Tensiunea de alimentare NOMINAL</p> <p>[4] Viteza max. de funcționare a motorului</p> <p>[5] Baterie (notă: nu este echipat cu baterie)</p> <p>[6] Capacitatea bateriei</p> <p>[7] Încărcător de baterie</p> <p>[8.1] Durata maximă a încărcării (o baterie)</p> <p>[8.2] Durata maximă a încărcării (două baterii)</p> <p>[9] Puterea motorului de tracțiune</p> <p>[10] Puterea motorului lamelor</p> <p>[11] Banda (benzile) de frecvențe în care funcționează echipamentul radio</p> <p>[12] Puterea maximă de radiofrecvență transmisă în banda (benzile) de frecvențe în care funcționează echipamentul radio.</p> <p>[13] Pneuri față</p> <p>[14] Pneuri spate</p> <p>[15] Presiune roți față</p> <p>[16] Presiune roți spate</p> <p>[17] Masă (fără baterie*)</p> <p>[18] Raza minimă de iarbă netăiată</p> <p>[19] Înălțime de tăiere</p> <p>[20] Lățime de tăiere</p> <p>[21] Viteza de deplasare la mersul înainte</p> <p>[22] Viteza de deplasare la mersul cu spatele</p> <p>[23] Înclinația maximă admisă</p> <p>[24] Dimensiuni</p> <p>[25] Lungime</p> <p>[26] Lungime cu sac (lungime fără sac)</p> <p>[27] Lățime</p> <p>[28] Lățime cu deflector de evacuare laterală (Lățime fără deflector de evacuare laterală)</p> <p>[29] Înălțime</p> <p>[30] Codul dispozitivului de tăiere</p> <p>[31] Nivel de presiune acustică</p> <p>[32] Nesiguranță în măsurare</p> <p>[33] Nivel de putere acustică măsurat</p> <p>[34] Nivel de putere acustică garantat</p> <p>[35] Nivel de vibrații la locul conducătorului</p> <p>[36] Nivel de vibrații la volan</p> <p>[49] Accesorii la cerere</p> <p>[49.A1, 49.A2] Kit pentru „mulching”</p> <p>[49.B1] Încărcător rapid de baterii - ștecher UE</p> <p>[49.B2] Încărcător rapid de baterii - ștecher din Marea Britanie</p> <p>[49.C] Kit de remorcare</p> <p>[49.D] Prelată pentru acoperire</p> <p>[49.E] Set de protecție pentru evacuare posterioară (numai pentru seriile MP)</p> <p>[49.F] Lanțuri de zăpadă</p> <p>[49.G] Roți de noroi / zăpadă</p> <p>[49.H] Remorcă</p> <p>[49.I] Distribuitor</p> <p>[49.J] Utilaj de dezzăpezire cu lamă</p> <p>[43] PRIZĂ AUXILIARĂ PENTRU ACCESORII USB</p> <p>[43.A] Tensiune și curent de încărcare (Ieșire USB)</p> <p>[43.B] Tipul</p> <p>[43.C] Numele și adresa fabricantului</p> <p>* Pentru informația specifică, consultați datele de pe eticheta de identificare a mașinii.</p> <p>** A se vedea presiunea indicată pe anvelope.</p>	<p>[1] RU - ТЕХНИЧЕСКИЕ ХАРАКТЕРИСТИКИ</p> <p>[2] Напряжение питания MAX</p> <p>[3] Напряжение питания NOMINAL</p> <p>[4] Макс. число оборотов двигателя</p> <p>[5] Аккумулятор (примечание: не оснащен аккумулятором)</p> <p>[5a] Литий-ионный (Li-on)</p> <p>[6] Ёмкость аккумулятора</p> <p>[7] Зарядное устройство</p> <p>[8.1] Максимальная продолжительность зарядки (одной батареи)</p> <p>[8.2] Максимальная продолжительность зарядки (двух аккумуляторов)</p> <p>[9] Мощность двигателя сцепления</p> <p>[10] Мощность двигателя резцов</p> <p>[11] Полосы рабочих частот радиооборудования</p> <p>[12] Максимальная мощность радиочастотного сигнала, передаваемого в полосах рабочих частот радиооборудования</p> <p>[13] Передние шины</p> <p>[14] Задние шины</p> <p>[15] Давление в передних шинах</p> <p>[16] Давление в задних шинах</p> <p>[17] Масса (без батареи*)</p> <p>[18] Минимальный радиус нескошенной травы</p> <p>[19] Высота скашиваемой травы</p> <p>[20] Ширина скашивания</p> <p>[21] Скорость хода (ориентировочная) при движении вперед</p> <p>[22] Скорость хода (ориентировочная) при движении задним ходом</p> <p>[23] Допустимый максимальный наклон</p> <p>[24] Габариты</p> <p>[25] Длина</p> <p>[26] Длина с контейнером (длина без контейнера)</p> <p>[27] Ширина</p> <p>[28] Ширина с боковым желобом для выброса (Ширина без бокового желоба для выброса)</p> <p>[29] Высота</p> <p>[30] Код режущего приспособления</p> <p>[31] Уровень звукового давления</p> <p>[32] Погрешность измерения</p> <p>[33] Измеренный уровень звуковой мощности</p> <p>[34] Гарантируемый уровень звуковой мощности</p> <p>[35] Уровень вибрации на месте водителя</p> <p>[36] Уровень вибрации на руле</p> <p>[49] принадлежности – навесные орудия по заказу</p> <p>[49.A1, 49.A2] Комплект для мульчирования</p> <p>[49.B1] быстрое зарядное устройство - вилка стандарта ЕС</p> <p>[49.B2] быстрое зарядное устройство - вилка для Великобритании</p> <p>[49.C] Прицепное устройство</p> <p>[49.D] Защитный чехол</p> <p>[49.E] Комплект защиты заднего выброса (только для серии MP)</p> <p>[49.F] Цепи противоскольжения</p> <p>[49.G] Колеса для грязи/ снега</p> <p>[49.H] Прицеп</p> <p>[49.I] Разбрасыватель</p> <p>[49.J] Шнекороторный снегоочиститель</p> <p>[43] Дополнительный разъем для аксессуаров usb</p> <p>[43.A] Напряжение и зарядный ток (Выход USB)</p> <p>[43.B] Тип</p> <p>[43.C] Наименование и адрес изготовителя</p> <p>* Точное значение см. на идентификационном ярлыке машины</p> <p>** См. давление, указанное на шинах</p>
--	---

[1] SK - TECHNICKÉ PARAMETRE

- [2] Napájacie napätie MAX
- [3] Napájacie napätie NOMINAL
- [4] Maximálna rýchlosť činnosti motora
- [5] Akumulátor (poznámka: nie je vybavený batériou)
- [6] Kapacita akumulátora
- [7] Nabíjačka akumulátora
- [8.1] Maximálne trvanie nabíjania (jedna batéria)
- [8.2] Maximálne trvanie nabíjania (dve batérie)
- [9] Výkon trakčného motora
- [10] Výkon motora nožov
- [11] Frekvenčné pásmo resp. pásma, v ktorých rádiové zariadenie pracuje
- [12] Maximálny vysokofrekvenčný výkon prenášaný vo frekvenčnom pásme, resp. pásmach, v ktorých rádiové zariadenie pracuje.
- [13] Predné pneumatiky
- [14] Zadné pneumatiky
- [15] Tlak hustenia predných pneumatík
- [16] Tlak hustenia zadných pneumatík
- [17] Hmotnosť (bez batérie*)
- [18] Minimálny akčný rádius otáčania
- [19] Výška kosenia
- [20] Šírka orezávania
- [21] Rýchlosť posunu (orientačná), pri posune vpred
- [22] Rýchlosť posunu (orientačná), pri spätnom chode
- [23] Maximálny povolený náklon
- [24] Rozmery
- [25] Dĺžka
- [26] Dĺžka s košom (dĺžka bez koša)
- [27] Šírka
- [28] Šírka vychylovača bočného vyhadzovania (Šírka bez vychylovača bočného vyhadzovania)
- [29] Výška
- [30] Kód kosiaceho zariadenia
- [31] Úroveň akustického tlaku
- [32] Nepresnosť merania
- [33] Úroveň nameraného akustického výkonu
- [34] Úroveň zaručeného akustického výkonu
- [35] Úroveň vibrácií na mieste vodiča
- [36] Úroveň vibrácií na volante

- [49] Prídavné zariadenia na požiadanie
- [49.A1, 49.A2] Súprava pre mulčovanie
- [49.B1] Rýchla nabíjačka batérií - zástrčka EÚ
- [49.B2] Rýchla nabíjačka batérií - zástrčka pre Spojené kráľovstvo
- [49.C] Súprava ťažného zariadenia
- [49.D] Krycia plachta
- [49.E] Súprava ochranného krytu zadného vyhadzovania (výlučne pre sériu MP)
- [49.F] Snehové refaze
- [49.G] Kolesá do blata / snehu
- [49.H] Prives
- [49.I] Posypávač
- [49.J] Snehová radlica

- [43] POMOČNÁ ZÁSUVKA PRE USB PRÍSLUŠENSTVO
- [43.A] Nabíjacie napätie a prúd (výstup USB)
- [43.B] Typ
- [43.C] Názov a adresa Výrobcu

* Ohľadne uvedeného parametra vychádzajte z hodnoty uvedenej na identifikačnom štítku stroja.

** Pozri tlak uvedený na pneumatikách.

[1] SL - TEHNIČNI PODATKI

- [2] Napetost električnega napajanja MAX
- [3] Napetost električnega napajanja NOMINAL
- [4] Najvišja hitrost delovanja motorja
- [5] Akumulator (opomba: ni opremljen z baterijo)
- [5a] z litijevimi ioni
- [6] Zmogljivost baterije
- [7] Polnilnik baterije
- [8.1] Najdaljši čas polnjenja (dva baterija)
- [8.2] Najdaljši čas polnjenja (dve bateriji)
- [9] Moč pogonskega motorja
- [10] Moč motorja rezil
- [11] Frekvenčni pasovi, na katerih deluje radijska oprema
- [12] Največja energija za radijsko frekvenco, preneseno po frekvenčnih pasovih, na katerih radijska oprema deluje
- [13] Prednje pnevmatike
- [14] Zadnje pnevmatike
- [15] Tlak v prednjih pnevmatikah
- [16] Tlak v zadnjih pnevmatikah
- [17] Masa (brez baterije*)
- [18] Najmanjše področje nepokošene trave
- [19] Višina košnje
- [20] Širina reza
- [21] Hitrost napredovanja (indikativna) pri vožnji naprej
- [22] Hitrost napredovanja (indikativna) pri vzvratni vožnji
- [23] Maksimalni dovoljen naklon
- [24] Dimenzije
- [25] Džžka
- [26] Džžka s košom (džžka bez koša)
- [27] Širina
- [28] Širina z odbijačem bočnega izmeta (Širina brez odbijača bočnega izmeta)
- [29] Višina
- [30] Šifra rezalne naprave
- [31] Raven zvočnega tlaka
- [32] Merilna negotovost
- [33] Izmerjena raven zvočne moči
- [34] Zajamčena raven zvočne moči
- [35] Stopnja vibracij na vozniškem sedežu
- [36] Nivo vibracij na volanu

- [49] Dodatni priključki na zahtevo
- [49.A1, 49.A2] Komplet za mulčenje
- [49.B1] Hitri polnilnik baterij - vtič EU
- [49.B2] Hitri polnilnik baterij - vtič za Združeno kraljestvo
- [49.C] Komplet za vleko
- [49.D] Prekrivno platno
- [49.E] Komplet ščitnika zadnjega izmeta (samo za MP serijo)
- [49.F] Snežne verige
- [49.G] Kolesa za blato / sneg
- [49.H] Prikolica
- [49.I] Trosilec
- [49.J] Snežni plug z nožem

- [43] POMOČNA VTIČNICA ZA USB OPREMO
- [43.A] Napetost in tok polnjenja (izhod USB)
- [43.B] Tip
- [43.C] Ime in naslov proizvajalca

* Za specifični podatek glej identifikacijsko nalepko stroja.

** Glejte tlak, ki je naveden na pnevmatikah.

<p>[1] SR - TEHNIČKI PODACI</p> <p>[2] Napon napajanja MAX</p> <p>[3] Napon napajanja NOMINAL</p> <p>[4] Maks. radna brzina motora</p> <p>[5] Baterija (napomena: nije opremljen baterijom)</p> <p>[6] Kapacitet baterije</p> <p>[7] Punjač baterije</p> <p>[8.1] Maksimalno trajanje napunjenosti (jedna baterija)</p> <p>[8.2] Maksimalno trajanje napunjenosti (dve baterije)</p> <p>[9] Snaga pogonskog motora</p> <p>[10] Snaga motora sečiva</p> <p>[11] Frekvencijski pojas (frekvencijski pojasevi) u kojem (u kojima) radijska oprema radi</p> <p>[12] Najveća radiofrekvencijska snaga koja se prenosi u frekvencijskom pojasu (frekvencijskim pojasevima) u kojem (u kojima) radijska oprema radi.</p> <p>[13] Prednje gume</p> <p>[14] Zadnje gume</p> <p>[15] Pritisak vazduha u prednjim gumama</p> <p>[16] Pritisak vazduha u zadnjim gumama</p> <p>[17] Masa (bez baterije*)</p> <p>[18] Minimalni poluprečnik nepokošene trave</p> <p>[19] Visina košenja</p> <p>[20] Širina košenja</p> <p>[21] Brzina kretanja (indikativna), napred</p> <p>[22] Brzina kretanja (indikativna), napred</p> <p>[23] Maksimalni dozvoljen nagib</p> <p>[24] Dimenzije</p> <p>[25] Dužina</p> <p>[26] Dužina s vrećom (dužina bez vreće)</p> <p>[27] Širina</p> <p>[28] Širina s usmerivačem bočnog izbacivanja (Širina bez usmerivača bočnog izbacivanja)</p> <p>[29] Visina</p> <p>[30] Šifra rezne glave</p> <p>[31] Nivo zvučnog pritiska</p> <p>[32] Merna nesigurnost</p> <p>[33] Izmereni nivo zvučne snage</p> <p>[34] Garantovani nivo zvučne snage</p> <p>[35] Nivo vibracija na mestu vozača</p> <p>[36] Nivo vibracija na volanu</p> <p>[49] Dodatna oprema na zahtev</p> <p>[49.A1, 49.A2] Komplet za malčiranje</p> <p>[49.B1] Brzi punjač baterija - EU utikač</p> <p>[49.B2] Brzi punjač baterija - UK utikač</p> <p>[49.C] Komplet za vuču</p> <p>[49.D] Pokrovna cerada</p> <p>[49.E] Komplet štitnika za izbacivanje otpozadi (edina za MP serija)</p> <p>[49.F] Lanci za sneg</p> <p>[49.G] Točkovi za blato / sneg</p> <p>[49.H] Prikolica</p> <p>[49.I] Posipač</p> <p>[49.J] Plug za sneg s nožem</p> <p>[43] Pomoćna utičnica za dodatni pribor usb</p> <p>[43.A] Napon i struja punjenja (izlaz USB)</p> <p>[43.B] Vrsta</p> <p>[43.C] Naziv i adresa proizvođača</p> <p>* Za specifični podatak, pogledajte podatke navedene na identifikacijskoj nalepnici mašine.</p> <p>** Pogledajte pritisak naveden na gumama.</p>	<p>[1] SV - TEKNISKA SPECIFIKATIONER</p> <p>[2] Spänning MAX</p> <p>[3] Spänning NOMINAL</p> <p>[4] Motorns maximala funktionshastighet</p> <p>[5] Batteri (obs: ej utrustad med batteri)</p> <p>[5a] Litiumjon (Li-on)</p> <p>[6] Batteriets kapacitet</p> <p>[7] Batteriladdare</p> <p>[8.1] Laddningens maximala varaktighet (ett batteri)</p> <p>[8.2] Laddningens maximala varaktighet (två batterier)</p> <p>[9] Drivmotorns effekt</p> <p>[10] Bladmotorns effekt</p> <p>[11] Det eller de frekvensband där radioutrustningen arbetar.</p> <p>[12] Den maximala radiofrekvenseffekt som överförs inom det eller de frekvensband där radioutrustningen arbetar.</p> <p>[13] Framdäck</p> <p>[14] Backdäck</p> <p>[15] Däcktryck fram</p> <p>[16] Däcktryck bak</p> <p>[17] Vikt (utan batteri*)</p> <p>[18] Minimiradie på oklippt gräs</p> <p>[19] Klipphöjd</p> <p>[20] Klippbredd</p> <p>[21] Hastighet (indikativ) vid körning framåt</p> <p>[22] Hastighet (indikativ) vid backning</p> <p>[23] Max. tillåten lutning</p> <p>[24] Dimensioner</p> <p>[25] Längd</p> <p>[26] Längd med påse (längd utan påse)</p> <p>[27] Bredd</p> <p>[28] Bredd med sidotömningens riktplatta (Bredd utan sidotömningens riktplatta)</p> <p>[29] Höjd</p> <p>[30] Skärenhetens kod</p> <p>[31] Ljudtrycksnivå</p> <p>[32] Tvivel med mått</p> <p>[33] Uppmått ljudeffektnivå</p> <p>[34] Garanterad ljudeffektnivå</p> <p>[35] Vibrationsnivå på förarplatsen</p> <p>[36] Vibrationsnivå på ratten</p> <p>[49] Fällvalstillbehör</p> <p>[49.A1, 49.A2] Sats för "mulching"</p> <p>[49.B1] Snabb batteriladdare - EU-kontakt</p> <p>[49.B2] Snabb batteriladdare - brittisk kontakt</p> <p>[49.C] Sats för bogsering</p> <p>[49.D] Presenning</p> <p>[49.E] Sats med bakre tömningsskydd (endast för MP-serien)</p> <p>[49.F] Snökedjor</p> <p>[49.G] Hjul för lera/snö</p> <p>[49.H] Spridare</p> <p>[49.I] Släp</p> <p>[49.J] Snöröjare med blad</p> <p>[43] Extra uttag för usb-tillbehör</p> <p>[43.A] Spänning och laddningsström (Utgång USB)</p> <p>[43.B] Typ</p> <p>[43.C] Tillverkarens namn och adress</p> <p>* För specifik information, se uppgifterna på maskinens märkplåt.</p> <p>** Se vilket tryck som anges på däck.</p>
--	--

[1] **TR - TEKNİK VERİLER**

- [2] Besleme gerilimi MAX
[3] Besleme gerilimi NOMINAL
[4] Motorun maksimum çalışma hızı
[5] Batarya (Not: PİL ile birlikte gelmez)
[6] Bataryanın kapasitesi
[7] Batarya şarj cihazı
[8.1] Bataryanın maksimum süresi (bir pil)
[8.2] Bataryanın maksimum süresi (iki pil)
[9] Traksiyon motorunun gücü
[10] Bıçak motorunun gücü
[11] Radyo cihazının çalışma frekans bandı
[12] Radyo cihazının çalıştığı frekans bantlarında iletilen azami radyofrekans gücü.
[13] Ön tekerlekler
[14] Arka tekerlekler
[15] Ön şişirme basıncı
[16] Arka şişirme basıncı
[17] Kütle (batarya olmadan*)
[18] Minimum kesilmemiş çim yarıçapı
[19] Kesim yüksekliği
[20] Kesim genişliği
[21] İleri yönde ilerleme hızı (gösterge niteliğindedir)
[22] Geri yönde ilerleme hızı (gösterge niteliğindedir)
[23] İzin verilen maksimum eğim
[24] Ebatlar
[25] Sepetli
[26] Sepetli uzunluk (sepetsiz uzunluk)
[27] Genişlik
[28] Yandan tahliye deflektörüyle genişlik (Yandan tahliye deflektörü olmadan genişlik)
[29] Yükseklik
[30] Kesim düzeni kodu
[31] Ses basınç seviyesi
[32] Ölçü belirsizliği
[33] Ölçülen ses gücü seviyesi
[34] Garanti edilen ses gücü seviyesi
[35] Sürücü mahalinde titreşim seviyesi
[36] Direksiyonda titreşim seviyesi

[49] Talep üzerine aksesuarlar
[49.A1, 49.A2] "Malçılama" Kıtı
[49.B1] Hızlı pil şarj cihazı - AB fişi
[49.B2] Hızlı pil şarj cihazı - İngiltere fişi
[49.C] Çekış Kıtı
[49.D] Kaplama Kıtı
[49.E] Arka tahliye koruma kıtı (sadece MP serisi için)
[49.F] Kar zincirleri
[49.G] Çamur / kar tekerleri
[49.H] Römork
[49.I] Serpici
[49.J] Bıçaklı kar temizleme makinesi

[43] USB AKSESUARLAR İÇİN YARDIMCI BAĞLANTI NOKTASI
[43.A] Şarj gerilimi ve akımı (Çıkış USB)
[43.B] tipi.
[43.C] Üreticinin adı ve adresi

* Spesifik değer için, makine belirleme etiketinde belirtilenleri referans alın

** Lastiklerin üzerinde gösterilen basıncı kontrol edin



INDICE

1. GENERAL INFORMATION.....	2	8. ROUTINE MAINTENANCE	21
2. GENERAL MACHINE SAFETY WARNINGS2		8.1 General Information.....	21
3. SAFETY WARNINGS FOR RIDE-ON LAWN MOWER WITH SEATED OPERATOR	5	8.2 Battery.....	21
3.1 Training.....	5	8.3 Anti-scalping wheels	23
3.2 Preliminary operations.....	5	8.4 Cleaning	23
3.3 During operation.....	5	8.5 Lubrication.....	24
3.4 Maintenance, storage.....	6	8.6 Nuts and bolts	24
3.5 Battery / battery charger	7	9. EXTRAORDINARY MAINTENANCE.....	24
3.6 Environmental protection.....	7	9.1 Safety recommendations.....	24
4. ABOUT THE MACHINE.....	7	9.2 Cutting means assembly / cutting means	25
4.1 Machine description and intended use 7		9.3 Replacing front / rear wheels	25
4.2 Components of the machine.....	8	10. STORAGE	26
4.3 Safety signs	9	11. HANDLING AND TRANSPORT.....	26
4.4 Identification label	9	12. ASSISTANCE AND REPAIRS.....	26
5. ASSEMBLY	9	13. WARRANTY COVERAGE	27
5.1 Assembly components.....	10	14. MAINTENANCE TABLE	28
5.2 Steering wheel assembly.....	10	15. TROUBLESHOOTING	28
5.3 Seat assembly.....	10	16. ATTACHMENTS	31
5.4 Mounting the rear bumper	10	16.1 "Mulching" kit.....	31
5.5 Side discharge chute assembly (for models with side discharge only).....	10	16.2 Battery charger (fast charge).....	31
5.6 Fitting of the side reinforcements of the cutting means assembly (for models with side discharge only, if available) .	11	16.3 Towing kit.....	31
5.7 Mounting and completing of the rear plate (only for models with rear grass catcher)	11	16.4 Canvas cover.....	31
6. CONTROLS	11	16.5 Rear discharge guard kit	31
6.1 Key ignition switch	11	16.6 Snow chains	31
6.2 Drive pedal	12	16.7 Mud / snow wheels.....	31
6.3 Transmission engagement / disengagement lever	12	16.8 Trailer.....	31
6.4 Cutting height adjustment.....	12	16.9 Sprinkler	31
6.5 Emergency button	12	16.10 Snow shovel	31
6.6 Auxiliary socket for USB accessories	13		
6.7 Warning buzzers.....	13		
6.8 Tipping lever for grass catcher (if available, only for models with rear grass catcher).....	13		
6.9 Pushbutton panel	13		
6.10 Bluetooth function.....	16		
7. USING THE MACHINE.....	16		
7.1 Preliminary operations.....	16		
7.2 Safety checks	17		
7.3 Using on slopes.....	19		
7.4 Start-up	19		
7.5 Operation	19		
7.6 Stop.....	20		
7.7 After use	21		

1. GENERAL INFORMATION

1.1 HOW TO READ THIS MANUAL

Some of the paragraphs in this manual contain particularly important information in terms of safety and operation, and are highlighted differently, according to the following criteria:

DANGER

Failure to comply with this warning gives rise to an imminent risk situation which, if not prevented, causes instant death or serious/permanent injury.

WARNING

Failure to comply with this warning gives rise to a potential risk situation which, if not prevented, may cause instant death or serious harm to health.

ATTENTION

Failure to comply with this warning gives rise to a potential risk situation which, if not prevented, could cause minor damage to the machine.

NOTICE

Provides an instruction that indicates the need to deal with situations not related to physical injury.

SAFETY INSTRUCTION

Provides an instruction referring to specific procedures to be followed if situations arise that may endanger human health or the safety of machines.

NOTE

Provides additional information to the instructions provided in the previous safety messages.

.....
The paragraphs highlighted in a dotted grey square indicate optional characteristics not available on all models documented in this manual. Check if this feature is available on this model.
.....

Whenever reference is made to a position on the machine "front", "back", "left" or "right" hand side, this refers to the operator's working position.

1.2 REFERENCES

1.2.1 Figures

The figures in these instructions for use are numbered 1, 2, 3, etc. Components shown in the figures are marked A, B, C, etc. Reference to component C in figure 2 is indicated with the wording: "See fig. 2.C" or simply "(Fig. 2.C)". The figures are provided by way of example. The actual pieces can differ from those illustrated in this document.

1.2.2 Titles

The manual is arranged in chapters and paragraphs. The title of paragraph "2.1 Training" is a sub-title of "2. Safety regulations". References to titles or paragraphs are marked with the abbreviation chap. or par. and the relevant number. Example: "chap. 2" or "par. 2.1"

2. GENERAL MACHINE SAFETY WARNINGS

2.1 GENERAL SAFETY WARNINGS

WARNING

Read all safety warnings, instruction, illustrations and specifications supplied with the machine. *Failure to follow all instructions listed below may result in electric shock, fire and/or serious injury.*

Save all warnings and instructions for future reference.

The term "power tool" indicated in the warnings refers to a machine powered through the electricity mains (with a power cable) or battery-powered equipment (without cable).

1) Work area safety

- a) **Keep the work area clean and well illuminated.** *Untidy or dark areas may cause accidents.*
- b) **Do not use power tools in explosive atmospheres, such as in the presence of flammable liquids, gases or powder.** *Power tools create sparks which may ignite the dust or fumes.*
- c) **Keep children and bystanders well away while using power tools.** *Distractions can cause you to lose control.*

2) Electrical safety

a) **The battery charging cable plug must match the outlet.**

Never modify the plug in any way. Do not use any adapter plugs with the earthed (grounded) battery charge cable.

Unmodified plugs and matching outlets will reduce the risk of electric shocks.

b) **The plug of the electric tool must be compatible with the power socket.**

Never modify the plug in any way. Do not use adapters with grounded power tools.

Unmodified plugs and matching outlets will reduce the risk of electric shocks.

c) **Avoid body contact with earthed or grounded surfaces, such as pipes, radiators, cookers and refrigerators.**

There is an increased risk of electric shock if your body is earthed or grounded.

d) **Do not expose power tools to rain or wet environments.**

Water entering a power tool will increase the risk of electrical shock.

e) **Never pull on the cord to remove the plug from the socket.**

Keep the battery charge cable away from heat, oil, solvents, sharp objects, sharp edges or moving parts. *Damaged or entangled cords increase the risk of electric shocks.*

f) **Do not use the cable improperly.**

Do not use the cable to carry, pull or disconnect the tool from the socket. Keep the cable away from heat, oil, sharp edges or moving parts. *Damaged or entangled cords increase the risk of electric shocks.*

g) **When using the power tool outdoors, use an extension cable suitable for outdoor use.**

Using an extension cable suitable for outdoor use reduces the risk of electric shock.

h) **If using a power tool in a humid environment cannot be avoided, use a power outlet protected by a residual current device (RCD).**

Using an RCD reduces the risk of electric shock.

i) **Only connect the battery charger to a socket with the mains frequency as indicated on the name plate.**

DANGER

Moisture and electricity are not compatible:

- Make sure your hands are dry when handling and connecting the electrical cables.
- Never connect an electrical socket or a cable in a wet area (presence of puddles or damp terrain).
- If necessary, use an extension cord with integrated watertight and type-approved sockets, available on the market.
- The pre-installation of a charging socket, connected to the mains power network of the building must be carried out by a qualified electrician and must be suitably protected by a differential (RCD-Residual Current Device) with a release current compliant with legislation in force.
- Incorrect connection can cause short circuits and serious personal injury, including death.

• **To prevent interruptions in the supply of electrical power during charging operations:**

- check that the overall capacity of the electrical system is suitable.
- connect the machine to a power socket with sufficient amperage.
- avoid simultaneous use of other electrical appliances with high energy draw.

3) Personal safety

a) **Stay alert, check what you are doing and use common sense when using a power tool. Do not use the power tool when you are tired or under the influence of drugs, alcohol or medicines.**

A moment of inattention while operating a power tool may result in serious personal injury.

b) **Use personal protective equipment (PPE). Always wear eye protection.**

Using protective equipment such as a dust mask, non-slip safety shoes, hard hat or hearing protection helps prevent personal injuries.

c) **Avoid unintentional starting.** Make sure that the switch is in the "OFF" position before inserting the plug, holding or carrying the electric power tool. *Carrying an electric tool with your finger on the switch or connecting to the mains socket with the switch in the "ON" position makes accidents more likely.*

d) **Remove any adjustment spanner or tool before switching the power tool on.** *A wrench or a tool left attached*

to a rotating part of the machine may result in personal injury.

- e) **Do not lean out. Keep proper footing and balance at all times.** *This ensures better control of the power tool in unexpected situations.*
 - f) **Dress appropriately. Do not wear loose clothes or jewellery. Keep hair and clothing away from moving parts.** *Loose clothes, jewellery or long hair can be caught in moving parts.*
 - g) **If devices have to be connected to powder extraction and collection systems, make sure they are connected and used appropriately.** *Using these devices may reduce powder-related hazards.*
 - h) **Do not allow familiarity acquired while using the machine to become complacent and ignore the safety principles of the power tool.** *A careless action can cause severe injury in a fraction of a second.*
- 4) **Using and looking after power tools**
- a) **Do not over-charge the power tool.** **Use a power tool appropriate for the task in question.** *The correct power tool will do the job better and safer at the speed for which it was designed.*
 - b) **Do not use the power tool if the switch does not turn it on and off.** *Any power tool that cannot be controlled with the switch is dangerous and must be repaired.*
 - c) **Do not use the machine if the key ignition switch does not turn it on and off.** *A machine which cannot be controlled with the key switch is dangerous and must be repaired at an Authorised Service Centre.*
 - d) **Remove the ignition key before making any adjustments, changing accessories, or before putting the power tool away.** *These preventive safety measures reduce the risk of accidental start-up of the power tool.*
 - e) **Store unused power tools out of the reach of children and do not allow persons who are not familiar with using the machine and these instructions to use it.** *Power tools are dangerous in the hands of untrained users.*
 - f) **Ensure regular maintenance of power tools and accessories. Check for misalignment or binding of moving parts, breakage of parts and any other condition that may affect power tool operation. In case of damage, the power tool must be repaired**

before it can be used. *Many accidents are caused by poor maintenance.*

- g) **Keep cutting tools sharp and clean.** *Properly maintained cutting tools with sharp cutting edges are less likely to bind and are easier to control.*
- h) **Use the power tool and its accessories in accordance with these instructions, taking into account the working conditions and the task to be performed.** *Using the power tool for operations other than those intended could result in a hazardous situation.*
- i) **Keep handles and grasping surfaces dry, clean and without any trace of oil or grease.** *Slippery grips and gripping surfaces do not allow safe movement and control of the tool in unexpected situations.*

5 Using and looking after battery-operated tools

- a) **Only use battery chargers recommended by the manufacturer to recharge batteries.** *A battery charger suitable for one type of battery pack can create a risk of fire, electric shock, overheating or leakage of corrosive battery fluid when used with another battery pack.*
- b) **Use only batteries specifically designed for your power tool.** *Use of any other battery packs may create a risk of injury and fire.*
- c) **When the batteries are not in use, they should be kept away from other metal objects such as paper clips, coins, keys, nails, screws or other small metal objects that could short-circuit the contacts.** *Short circuits between battery contacts can lead to explosion or fires.*
- d) **A battery in poor condition may allow fluid to leak from it.** *Avoid contact with battery fluids. In case of accidental contact, rinse with water. If battery fluids come into contact with the eyes, also consult a doctor. Liquid leaked from the battery may cause skin irritation or burns.*
- e) **Do not use a machine or battery pack that are damaged or modified.** *Damaged or modified batteries may exhibit unpredictable behaviour resulting in fire, explosion or risk of injury.*
- f) **Do not expose the battery pack or the tool to fire or excessively high temperatures.** *Exposure to fire or temperatures exceeding 130°C may cause an explosion.*
- g) **Follow all the charging instructions and do not charge the battery pack**

or tool outside the temperature range specified in the instructions. *Improper charging or at temperatures outside the specified range can damage the batteries and increase the risk of fire.*

- h) **Do not charge the battery pack in places with vapours or flammable substances present or in rooms which are damp.** If it is not possible to avoid damp environments, use a power socket protected by a differential switch (RCD-Residual Current Device) to reduce the risk of electric shocks.
- i) **Keep the battery charge cable out of the reach of children.**

6) Technical Assistance

- a) **Have your power tool serviced by a qualified repair person using only identical replacement parts.** *This will ensure that the safety of the power tool is maintained.*
- b) **Do not carry out repairs on the battery.** *Repairs must be carried out by the manufacturer or by a specialized service centre.*

3. SAFETY WARNINGS FOR RIDE-ON LAWN MOWER WITH SEATED OPERATOR

3.1 TRAINING

- Become acquainted with the controls and the proper use of the machine. Learn how to stop the machine quickly.
- Never allow the machine to be used by children or individuals who are not familiar with the instructions. Local laws may establish a minimum age for users.
- Do not allow children or other passengers to ride on the machine.
- Bear in mind that the user is responsible for accidents or unexpected events occurring to other people or their property. It is the user's responsibility to assess the potential risk of the area where work is to be carried out and to take all the necessary precautions to ensure his own safety and that of others, particularly on slopes or rough, slippery and unstable ground.
- This manual is an integral part of the machine and therefore must always accompany it in the case of temporary or definitive transfer.

3.2 PRELIMINARY OPERATIONS

Personal Protective Equipment (PPE)

- Wear suitable clothing, strong work shoes with anti-slip soles, and long pants. Do not operate the machine barefoot or wearing open sandals. Wear hearing protection devices.
- Use of hearing protections can reduce the ability to hear any warnings (shouting or alarms). Be careful of what occurs around you in the work area.
- Never wear scarves, shirts, necklaces, bracelets, loose flowing clothing, laces or ties or any hanging or flapping accessory that could catch in the machine or in any objects or materials in the work area.
- Tie up long hair.

Work / Machine Area

Thoroughly inspect the entire work area and remove anything that could be thrown by the machine or damage the cutting means/rotating units (stones, branches, iron wire, bones, etc.).

3.3 DURING OPERATION

Work Area

- Do not use the machine in environments that pose the risk of explosion, in the presence of flammable liquids, gases or powders. Electrical contact or mechanical rubbing can generate sparks that can ignite powder or vapour.
- Work only in daylight or with good artificial light in good visibility conditions.
- Keep people, children and animals away from the work area. Children must be supervised by another adult.
- Avoid working with wet grass, in the rain and when there is a risk of a thunderstorm, and especially of lightning.
- Pay careful attention to uneven ground (hills, dips), slopes, hidden hazards and obstacles that could limit visibility.
- Be very careful near ravines, ditches or embankments. The machine could overturn if a wheel slides over the edge or if the earth gives way.
- Pay close attention on sloping ground which requires special care to prevent overturning or loss of control of the machine. The main reasons for loss of control are:
 - Insufficient wheel grip.
 - Excessive speed.
 - Sharp changes of direction.
 - Inadequate braking.
 - Type of machine unsuitable for its task.
 - Lack of awareness of the effect of ground conditions.

- Using the machine for towing.
- Look out for traffic when using the machine near the road.

NOTICE

The machines detailed in this manual are not designed for use as towing vehicles.

Conduct

- When working behind the wheel, do not become distracted and maintain the required level of concentration.
- Exercise caution when reversing or moving backwards. Look behind you to make sure there are no obstacles before and during operations in reverse gear.
- Pay careful attention when using the attachments that can alter the stability of the machine, especially on slopes.
- Always keep hands and feet away from the cutting means, when starting and when using the machine.
- Keep hands and feet away from the seat support. There is the risk of crushing injuries.

WARNING

the cutting means will continue to rotate for a few seconds after disengagement or after switching off the motor.

WARNING

Pay attention to the cutting means assembly with more than one cutting element, since one rotating cutting means can trigger rotation of the others.

SAFETY INSTRUCTION

If something breaks or an accident occurs during work, turn off the motor immediately and move the machine away to prevent further damage; if an accident occurs with injuries or third parties are injured, carry out the first aid measures most suitable for the situation immediately and contact the medical authorities for any necessary health care. Carefully remove any debris which could cause damage or injury to persons or animals if ignored.

Restrictions of use

- Never operate the machine with guards damaged, missing or incorrectly assembled (grass catcher, side discharge guards rear discharge guards)
- Don't use the machine if the attachments/ tools are not installed in their seats.

- Never disengage, deactivate, remove or tamper with the safety systems/ micro switches installed.
- Do not strain the machine too much and do not use an inappropriate machine for heavy-duty work; if you use the correct machine, you will reduce the risk of hazards and improve the quality of your work.
- The machine has not been approved for use on public roads. It must be used (as indicated by the highway code) in private areas closed to traffic.

3.4 MAINTENANCE, STORAGE

Ensure regular maintenance and correct storage to maintain machine safety and high performance levels.

Maintenance

- Never use the machine with worn or damaged parts. Faulty or worn-out parts must always be replaced and never repaired.
- Be careful during adjustment of the machine to prevent entrapment of the fingers between moving parts of the cutting means and fixed parts of the machine.
- Have your machine serviced by a qualified repair person using only identical replacement parts. This will ensure that the safety of the machine is maintained.
- Do not carry out repairs on the battery. Repairs must be carried out by the manufacturer or by a specialized service centre.

SAFETY INSTRUCTION

The noise and vibration levels shown in these instructions are the maximum levels when using the machine. The use of an unbalanced cutting element, the excessive speed of movement, or the absence of maintenance have a significant influence on noise emissions and vibrations. Consequently, it is necessary to take preventive steps to eliminate possible damage due to high levels of noise and stress from vibration; maintain the machine well, wear ear protection devices, and take breaks whilst working.

Storage

To reduce fire risks, do not leave containers with debris inside a room.

3.5 BATTERY / BATTERY CHARGER

- Only use battery chargers recommended by the manufacturer to recharge batteries. An inadequate battery charger may cause electric shock, overheating or corrosive liquid to leak from the battery.
- Use only batteries specifically designed for your machine. The use of other batteries may cause injuries and fire risks.
- Keep unused batteries away from metal objects (office clips, coins, keys, nails, screws, etc.) which could cause a short circuit of the contacts. Short circuits between battery contacts can lead to explosion or fires.
- Never use the battery charger in environments in the presence of vapours, flammable substances or on easily flammable surfaces such as paper, fabric, etc. The battery charger heats up during recharging and may cause a fire.
- When transporting batteries, make sure the contacts never come into contact with each other and never use metal containers to transport them.
- Only connect the battery charger to a socket with the mains frequency as indicated on the name plate.
- The battery charging cable plug must match the outlet. Never modify the plug in any way. Do not use any adapter plugs with the earthed (grounded) battery charge cable. Unmodified plugs and matching outlets will reduce the risk of electric shocks.
- To prevent interruptions in the supply of electrical power during charging operations:
 - check that the overall capacity of the electrical system is suitable;
 - connect the machine to a power socket with sufficient amperage;
 - avoid simultaneous use of other electrical appliances with high energy draw.
- Keep the battery charge cable out of the reach of children.
- Do not charge the single battery inserted into the machine.
- The charger must not be exposed to water or humidity. Be careful not to place containers containing liquids near the charger.

3.6 ENVIRONMENTAL PROTECTION

Protecting the environment must be a significant and top priority for machine use, to the benefit of civil co-habitation and of the environment that we live in.

- Scrupulously comply with local regulations for the disposal of packaging, deteriorated parts or any elements with a strong environmental impact; this waste must

- not be disposed of with regular waste, but must be separated and taken to collection centres, which will recycle the materials.
- Comply with local regulations for the disposal of waste materials.
- When the machine is withdrawn from service, do not dispose of it in the environment, but take it to a waste disposal facility in accordance with the local regulations in force.



Do not throw electrical equipment away with domestic waste. In observance of European Directive 2012/19/EU on electrical and electronic equipment waste and its implementation, in observance of UK Regulation "The waste electrical and electronic equipment regulations 2013 (as amended)" and in accordance with national regulations, old electrical equipment must be collected separately, for eco-compatible recycling. If electrical equipment is disposed of in dumps or in landfills, hazardous substances can leak into the groundwater and contaminate the food chain, damaging your health and well-being. For further information on the disposal of this product, contact your dealer or a domestic waste collection service.



At the end of their working life, dispose of batteries with all due care and in compliance with applicable local legislation. Batteries contain materials classified as hazardous for people and the environment. They must be removed and disposed of separately at a facility that accepts lithium-ion batteries.



Separate waste collection of the products and packaging used allows the materials to be recycled and reused. Reuse of recycled materials help to prevent environmental pollution and reduces the demand for raw materials.

4. ABOUT THE MACHINE

4.1 MACHINE DESCRIPTION AND INTENDED USE

This machine is a ride-on lawn mower with seated operator.

The machine is equipped with an electric motor that drives the cutting means and an electric drive motor. The machine has rear-wheel drive.

The operator is able to operate the machine and use the main controls, always seated in the operator's position.

The safety devices installed on the machine will disengage the engine and cutting means in a couple of seconds (par. 7.2.2).

4.1.1 Intended use

This machine was designed and built to cut grass in gardens and grassy areas. The use of special attachments provided for by the Manufacturer as original equipment or which may be purchased separately, allows this work to be done in various operating modes, illustrated in this manual or the instructions that accompany the single attachments. Likewise, the intended use can be extended to include other functions by applying supplementary attachments (if provided for by the Manufacturer), abiding by the restrictions and conditions indicated in the instructions accompanying the attachment.

4.1.2 Improper use

Any use other than those mentioned above may be hazardous and cause harm to persons and/or damage things. Examples of improper use may include, but are not limited to:

- Allowing children, animals or other passengers on the machine as they could fall off and injure themselves or compromise safe driving by the operator;
- Using the machine to push loads;
- Using the machine for riding over unstable, slippery, icy, stony, rough, marshy ground or puddles that do not allow the consistency of the ground to be assessed;
- Using the cutting means on surfaces other than grass;
- Using of the machine for leaf or debris collection.

NOTICE

Improper use of the machine will void the warranty and relieves the Manufacturer of any liability, placing all responsibility for damage or injury, to him/herself or third parties, on the user.

AVVISO

The machine must be used by a single operator.

AVVISO

The vehicle is not approved for use on public roads. Its use (pursuant to the Highway Code) must take place exclusively in private areas closed to traffic.

4.1.3 Type of user

This machine is intended for use by consumers, i.e. non-professional operators. It is intended for "hobby use" and must be only used by a single operator.

4.2 COMPONENTS OF THE MACHINE

The machine comprises the following main components having the following functions (fig.1):

- A. Cutting means assembly:** this is the assembly comprising the casing housing the rotating cutting means assembly and the cutting means.
- B. Cutting means:** these are what cut the grass; the fins at the ends help convey the cut grass towards the discharge chute.
- C. Side discharge chute:** it is a safety protection and prevents any objects collected by the cutting means from being thrown away from the machine (only for models with side discharge).
- D. Discharge chute:** this is the part connecting the cutting means assembly to the grass catcher (for models with rear collector only).
- E. Grass catcher:** in addition to collecting the mown grass, the grass catcher also constitutes a safety element, since it prevents any objects picked up by the cutting means from being projected long distance from the machine (for models with rear collector only).
- F. Rear discharge guard (available upon request):** this can be fitted in place of the grass catcher and prevents objects from being drawn up by the cutting means and hurled away from the machine (for rear collection models only).
- G. Driving seat:** this is where the machine operator sits. It has a sensor connected to safety devices for detecting the presence of the operator.
- H. Blade motor:** drives the cutting means.
- I. Drive motor:** drives the wheels.
- J. Battery:** provides power to the motor and all electrical components of the machine.
- K. Front bumper:** this protects the front section of the machine.
- L. Steering wheel:** turns the front wheels.
- M. Pushbutton panel:** interface comprising all the main commands for using the machine.

4.3 SAFETY SIGNS

The machine has various symbols on it (fig. 2). Their function is to remind the operator of the correct conduct for use, with due care and caution.

Meanings of the symbols:



ATTENTION

Read the instructions before use.



ATTENTION

Remove the key and read the instructions before carrying out any maintenance or repair work.



HAZARD OF EJECTED OBJECTS.

Do not operate without either the rear discharge guard or the grass catcher being in place. (for models with rear collection system only).



HAZARD OF EJECTED OBJECTS.

Do not work without having fitted the side discharge chute. (only for models with side discharge)



HAZARD OF EJECTED OBJECTS.

Keep all persons away and outside the work area during machine use.



RISK OF MACHINE ROLL-OVER:

Do not use the machine on gradients in excess of 10°.



CRUSHING HAZARD

Make sure that children remain at a safe distance from the machine when it is running.



CUTTING HAZARD

Cutting means in operation. Do not insert hands or feet into the cutting means housing.

⚠ SAFETY INSTRUCTION

Any damaged or illegible decals must be replaced. Order replacement decals from an Authorised Service Centre.

4.4 IDENTIFICATION LABEL

The identification label includes the following data (fig. 1):

1. Sound power level.
2. Conformity marks.
3. Year of manufacture.
4. Type of machine.
5. Serial number.
6. Name and address of Manufacturer.
7. Article code.
8. Max. motor operation speed.
9. Weight in kg.
10. Electrical protection rating.
11. Rated voltage.
12. Battery capacity.

Write the identification data of the machine in the specific space on the label on the back of the cover page.

⚠ SAFETY INSTRUCTION

State the identification data on the product identification label whenever you contact an Authorised Service Centre.

NOTE

An example of the Declaration of Conformity is provided on the last pages of this manual.

5. ASSEMBLY

⚠ WARNING

The safety regulations to follow are described in chap. 2. Strictly comply with these instructions to avoid serious risks or hazards. Do not use the machine until all the instructions provided in the "ASSEMBLY" section have been carried out.

For storage and transport purposes, some components of the machine are not installed in the factory and have to be assembled after unpacking.

Unpacking and completing the assembly should be done on a flat and stable surface, with enough space for moving the machine and its packaging, always making use of suitable equipment.

5.1 ASSEMBLY COMPONENTS

The packaging holds the components needed for assembly as listed in the table below:

	Description
1	Steering wheel
2	Dashboard cover and steering wheel assembly parts
3	Driving seat
4	Battery charger
5	Front bumper
6	Anti-scalping wheels
7	Grass catcher with relative mounting screws and relative instructions (only for models with rear grass catcher)
8	Lower part of the rear plate, the grass catcher bag supports and relative attachment and fitting accessories (only for models with rear grass catcher)
9	Side discharge chute (for models with side discharge only)
10	Side reinforcements of the cutting means assembly (for models with side discharge only, if available)
11	Envelope containing: - the instruction manuals and documents - driving seat assembly screws - side discharge chute assembly fittings (for models with side discharge only) - 2 starter keys
12	Mobile phone holder kit

5.1.1 Unpacking

1. Carefully open the packaging, paying attention not to lose components.
2. Consult the documentation in the box, including these instructions.
3. Remove all the unassembled parts from the box.
4. Remove the machine from the packaging taking the following precautions:
 - move the cutting means assembly to its maximum height (par. 6.4) to protect it against damage when the machine is lifted off the base pallet;
 - Move the front drive release lever to the released position (par. 6.3);
 - Lift the machine off the base pallet.

5.2 STEERING WHEEL ASSEMBLY

1. Put the machine on a flat surface and straighten the front wheels.
2. Fit the hub on the steering shaft making sure that the pin is correctly inserted into its seat in the hub (fig. 3).
3. Replace the cap on the dashboard inserting the five fittings so they click into place.
4. Fit the steering wheel on the hub with the spokes pointing towards the seat.
5. Fix the steering wheel using the supplied screws in the indicated sequence (fig. 3).
6. Pre-assemble the cell phone holder on the steering wheel cover (fig. 3).
7. Apply the steering wheel cover using the supplied screws.

5.3 SEAT ASSEMBLY

Fit the seat on the plate using cam levers (fig. 4). Make sure the seat slides freely before tightening the cam levers.

5.4 MOUNTING THE REAR BUMPER

- 1a. **Only for bumper of type "I"** - Fit the front bumper (fig. 5.A) on the lower part of the frame (fig. 5.B) using the four screws (fig. 5.C).
- 1b. **Only for bumper of type "II"**
 1. Fit the two supports (fig. 5.A) and (fig. 5.B) on the lower part of the frame (fig. 5.C) observing the fitting order indicated in the figure R= right; L= left.
 2. Fully tighten the screws (Fig. 5.D).
 3. Fix the front bumper (fig. 5.E) to the supports (fig. 5.A) and (fig. 5.B) using the screws (fig. 5.F) and nuts (fig. 5.G).

5.5 SIDE DISCHARGE CHUTE ASSEMBLY (FOR MODELS WITH SIDE DISCHARGE ONLY)

1. From the inside of the side discharge chute (fig. 6.A), fit the spring (fig. 6.B) by inserting the terminal (fig. 6.B.1) into the hole and turning it so that both the spring (fig. 6.B) and the terminal (fig. 6.B.2) are securely positioned in their housings.
2. Position the side discharge chute (fig. 6.A) in line with the cutting means assembly brackets (fig. 6.C). Using a screwdriver, turn the second terminal (fig. 6.B.2) of the spring (fig. 6.B) to bring it outside the side discharge chute.

3. Fit the pin (fig. 6.D) in the holes on the brackets (fig. 6.C) and on the side discharge chute, so that it passes through the coils of the spring (fig. 6.B) and the drilled end comes out of the inner most bracket.
4. Insert the cotter pin (fig. 6.E) into the hole (fig. 6.D.1) on the pin (fig. 6.D) and rotate the pin in order to bend the two ends (fig. 6.E.1) of the cotter pin, (with the aid of a pair of pliers), so that it cannot slide out, causing the pin (fig. 6.D) to disengage.

WARNING

Check that the spring works correctly and keep the side discharge chute securely lowered. Make sure that the pin is fitted properly to prevent it from falling out accidentally. make sure that the side discharge guard (Fig. 7.A) is lowered and locked with the safety lever (Fig. 7.B).

ATTENTION

Before disassembling or servicing the deflector, always push the safety lever (Fig. 8.B) and lift the side unloading guard (Fig. 8.A) to allow disassembly.

NOTE

To remove the deflector, perform assembly steps in reverse order.

5.6 FITTING OF THE SIDE REINFORCEMENTS OF THE CUTTING MEANS ASSEMBLY (FOR MODELS WITH SIDE DISCHARGE ONLY, IF AVAILABLE)

Finish the fitting cutting means assembly mounting the side reinforcements on the profile of the cutting means assembly using the relative screws (fig. 9)

5.7 MOUNTING AND COMPLETING OF THE REAR PLATE (ONLY FOR MODELS WITH REAR GRASS CATCHER)

1. Remove the two screws (fig. 10.H), which will be used later.
2. Fit the lower part (fig. 10.E) of the rear plate and fix it to the lower brackets with the screws (fig. 10.F) and nuts (fig. 10.G), without tightening them completely.
3. Complete the fastening of the lower part (fig. 10.E) of the rear plate by fully tightening the two central screws (fig. 10.H) previously removed and the four upper screws (fig. 10.I)
4. Fully tighten the two lower nuts (fig. 10.G).
5. Insert the lever (fig. 10.J) of the full collection bag indicator in its seat (fig. 10.K) and push it down until a click is heard.
6. Fit the two supports of the grass catcher (fig. 10.L) and (fig. 10.M), respecting the assembly sequence indicated in the figure, and fix them with the screws (fig. 10.N) and spring washers (fig. 10.O), tightening them fully.

6. CONTROLS

6.1 KEY IGNITION SWITCH

This key-operated command serves as the main switch to enable or disable the machine's ignition circuit. The key-operated switched (fig. 12.A) has 2 positions:

1. **Key removed.** The power circuit is disabled and the machine turns off. No function can be activated.
2. **Key fully inserted.** the machine is ready to be turned ON.

6.2 DRIVE PEDAL

The drive pedal (Fig. 12.F) activates wheel drive and adjusts machine speed in forward and reverse gears.



1. **Forward drive gear:** by pressing the pedal forwards, the machine advances. Increasing the pressure on the pedal progressively increases the speed of the machine.



2. **Reverse drive gear:** by pressing the pedal backwards, the machine moves in reverse gear. Reducing the pressure on the pedal progressively reduces the speed of the machine.
3. **Parking:** when the pedal is released, a service brake engages automatically which serves to decelerate and stop the machine, preventing any additional movement until the drive pedal is once again pressed.

NOTE

The drive pedal deactivates when the operator leaves the seat.

6.3 TRANSMISSION ENGAGEMENT / DISENGAGEMENT LEVER

The transmission engagement/disengagement lever (Fig. 12.H) allows the machine to be moved manually without having to switch on the machine. This command has two positions, indicated by the following symbols:



1. **Drive engaged :** move the lever (fig. 12.H) into the horizontal position (A). The machine can be moved normally by starting the machine.



2. **Transmission disengaged:** move the lever (fig. 12.H) downwards (B). The machine can be moved manually without having to start the machine.

WARNING

Only move the machine manually on a level surface.

SAFETY INSTRUCTION

The engagement/disengagement lever must never be in the intermediate position. This condition will cause overheating and damage the transmission.

6.4 CUTTING HEIGHT ADJUSTMENT

6.4.1 Adjustment lever (only for models of type "I" and "II")

This lever (fig. 12.G) is used to raise and lower the cutting means assembly, which may be positioned at 7 different cutting heights.



The seven positions for this lever, shown as «1» to «7» on the label, correspond to various cutting heights between 3 and 8 cm.



To move from one position to another, the lever must be moved sideways and repositioned in one of the stop notches.

6.5 EMERGENCY BUTTON

The emergency button (Fig. 12.B) allows the machine to be stopped immediately in the event of an emergency.

The button has two positions:



1. **Activated:** pressing the emergency button stops the cutting means motors and drive control devices.



2. **Deactivated:** turn the emergency button clockwise to deactivate it and restore all functions. To start the machine, repeat the starting procedure using the key (par.7.4).

NOTE

The machine cannot be started when the emergency button is activated.

NOTICE

The emergency button should never be used as a routine method for stopping the machine.

6.6 AUXILIARY SOCKET FOR USB ACCESSORIES

This socket (fig. 12.I) can charge USB devices. It only has a recharging function. The socket has no communication function with the connected USB device.

The socket is only live when the key (fig. 12.A) is fully inserted.

Do not recharge the accessory connected to the USB socket in rainy, humid or high temperature conditions with direct exposure to sunlight. Use in these conditions invalidates the warranty and waives the Manufacturer from any liability in the event of problems.

Do not open the USB plug in rainy or dusty areas.

The Manufacturer declines any and all liability in the event of damage to the accessory connected to the USB socket or loss of data during its use.

6.7 WARNING BUZZERS

- A double buzzer signal indicates that the grass catcher has not been fitted. Check the presence or correct assembly of the grass catcher (only for models with rear grass catcher).
- A continuous buzzer signal indicates that the grass catcher is full. Empty it (see par. 7.5.4) (only for models with rear grass catcher).
- A single buzzer signal indicates the lack of consent for reverse cutting. See icon fig. 13.C.
- The emission of an intermittent sound signal indicates that the key is inserted but the machine has not been started within a few minutes of its insertion.

6.8 TIPPING LEVER FOR GRASS CATCHER (IF AVAILABLE, ONLY FOR MODELS WITH REAR GRASS CATCHER)

This lever, removable from its seat, allows the grass catcher to be overturned for emptying, reducing the effort required by the operator (fig. 12.E).

6.9 PUSHBUTTON PANEL

Depending on the model, the machine can be equipped with one of the pushbutton panel versions (fig. 12.C, fig. 12.D) described below:

6.9.1 Pushbutton panel (*type "I"*) fig. 13



Machine start button

With the key fully inserted this button (fig. 13.A) turns the machine ON and enables all functions.

NOTE

If all safety conditions are met, the "READY" icon comes ON (fig. 13.K) and the machine is ready to be used (see par. 7.4).



Cutting means engage and disengage pushbutton

Press the button fig. 13.B to engage/disengage the cutting means.

- When the cutting means are engaged, they become operational after a few seconds.
- When the cutting means are disengaged, a brake is applied simultaneously to stop them rotating after a few seconds.

NOTE

If the cutting means are engaged without taking the necessary safety precautions, the machine shuts down and cannot be restarted (see par. 7.2.2)



Reverse gear cutting enable button

Pressing the button once fig. 13.C gives consent for reverse mowing.

For reverse cutting, engage the cutting means and simultaneously press the button once.

NOTE

A single buzzer signal indicates the lack of consent for reverse cutting.



Beacon ON button

Pushing the button fig. 13.D turns the beacon on/off.

When the beacons are ON, icon fig. 13.L is illuminated



Attention icon

If icon fig. 13.E is illuminated, it this indicates failure to comply with safety conditions or a possible malfunction of the machine (see chap. 15).



Battery LED

The LEDs fig. 13.F generally indicate the charge level of the machine's batteries but in particular combinations their lighting status provides information about machine malfunctions (see chap. 15).



"Ready" icon

The icon in fig. 13.K is illuminated when the machine is ON and ready to be used.



"Bluetooth" icon

The icon in fig. 13.M is illuminated when the machine and the data exchange device are connected.



Controller and/or motor over-temperature icon

The icon in fig. 13.N indicates overheating of electrical components. See chap. 15.



Transmission engagement / disengagement lever icon

The icon in fig. 13.O is illuminated when the transmission is not engaged (see par. 6.3 and chap. 15).



Operator on-board icon

The icon in fig. 13.P is illuminated when operator leaves the driving seat (see par. 7.2.2).



Emergency pushbutton icon

The icon in fig. 13.Q is illuminated if the emergency button is activated (see par. 6.5).

6.9.2 Pushbutton panel (type "II") fig. 13



Machine start button

With the key fully inserted this button (fig. 13.A) turns the machine ON and enables all functions.

NOTE

If all safety conditions are met, the "READY" icon comes ON (fig. 13.K) and the machine is ready to be used (see chap. 7.4).



Cutting means engage and disengage pushbutton

Press the button fig. 13.B to engage/disengage the cutting means.

- When the cutting means are engaged, they become operational after a few seconds.
- When the cutting means are disengaged, a brake is applied simultaneously to stop them rotating after a few seconds.

NOTE

If the cutting means are engaged without taking the necessary safety precautions, the machine shuts down and cannot be restarted (see par. 7.2.2)



Reverse gear cutting enable button

Pressing the button once fig. 13.C gives consent for reverse mowing.

For reverse cutting, engage the cutting means and simultaneously press the button once.

NOTE

A single buzzer signal indicates the lack of consent for reverse cutting.



Beacon ON button

Pushing the button fig. 13.D turns the beacon on/off.

When the beacons are ON, icon fig. 13.L is illuminated



"CRUISE CONTROL" button

Pressing the button in fig. 13.G activates/deactivates the "CRUISE CONTROL" function. The Cruise Control command is used to maintain the desired speed in forward gear without having to keep the drive pedal pressed.

- By pressing the "CRUISE CONTROL" button (Fig. 13.G) while moving forwards, the machine will maintain the speed reached at that moment, without the driver having to act on the drive pedal (Fig. 12.F). When the function is active, the icon in fig. 13.I. is illuminated

NOTE

The "CRUISE CONTROL" function cannot be activated in reverse gear.

NOTE

Speeds may vary with respect to the selected values when the machine is moving up or down slopes.

To disengage the device and reset speed control using the drive pedal (fig. 12.F) simply:

- press the button fig. 13.G.
- Or
- press the drive pedal (fig. 12.F).



Cutting means operating speed selector button

This button (fig. 13.H) is used to select 3 different cutting means rotation speeds.

1. ECO: The cutting means rotation speed is reduced to extend the battery life. When this function is selected, the "leaf" icon is illuminated (fig. 13.J).

ATTENTION

It is not recommended to use this function in heavy grass cutting conditions (cutting of dense, high, humid grass).

2. NORMAL: standard cutting means rotation speed for use in normal mowing conditions
3. BOOST: The rotation speed of the cutting means is increased to cut grass in more difficult conditions (dense, tall, wet grass). When this function is selected, the "rotary blade" icon is illuminated (fig. 13.R). Battery life is reduced.

Attention icon

If icon fig. 13.E is illuminated, it this indicates failure to comply with safety conditions or a possible malfunction of the machine (see chap. 15).



Battery LED

The LEDs fig. 13.F generally indicate the charge level of the machine's batteries but in particular combinations their lighting status provides information about machine malfunctions (see chap. 15).



"Ready" icon

The icon in fig. 13.K is illuminated when the machine is ON and ready to be used.



"Bluetooth" icon

The icon in fig. 13.M is illuminated when the machine and the data exchange device are connected.



Controller and/or motor over-temperature icon

The icon in fig. 13.N indicates overheating of electrical components. See chap. 15.





Transmission engagement / disengagement lever icon

The icon in fig. 13.O is illuminated when the transmission is not engaged (see par. 6.3 and chap. 15).



Operator on-board icon

The icon in fig. 13.P is illuminated when operator leaves the driving seat (see par. 7.2.2).



Emergency pushbutton icon

The icon in fig. 13.Q is illuminated if the emergency button is activated (see par. 6.5).



ECO icon

The icon in fig. 13.J is illuminated when the ECO mowing mode is selected.



BOOST icon

The icon in fig. 13.R is illuminated when the BOOST mowing mode is selected.

6.10 BLUETOOTH FUNCTION

The Bluetooth function provides short-distance direct wireless connection between the machine and another device. The specific data exchange App must be installed on the device:

1. Download the App using the QR Code shown in fig. 11.
2. Follow the instructions.



The bluetooth connection is activated automatically when the machine is started and successful connection with the device is confirmed when the icon in fig. 13.M is illuminated.

Make sure that the connection with the device/App is active.

7. USING THE MACHINE

WARNING

The safety regulations to follow are described in chap. 2. Strictly comply with these instructions to avoid serious risks or hazards.

7.1 PRELIMINARY OPERATIONS

Before starting to mow, it is necessary to carry out several checks and operations to ensure you can work efficiently and in maximum safety.

7.1.1 Checking the battery

Charge the battery fully before using the machine for the first time after purchase (chap. 8.2.3).

Always check the battery state of charge before using the machine (Fig. 13.F).

7.1.2 Seat adjustment

To change the position of the seat, loosen the two cam levers (fig. 14.A) and slide the seat along the slots in the support. When the required position is found, fully tighten the two cam levers (fig. 14.A).

7.1.3 Tyre pressure

Having the right tyre pressure is the main condition for ensuring that the cutting means assembly is horizontal and mows evenly.

1. Unscrew the protective caps
2. Connect a compressed air line with a gauge to the valves (fig. 15)
3. Adjust the pressure according to the values indicated in the "Technical Data" chart.

7.1.4 Preparing the machine before starting work

NOTE

This machine can be used to mow lawns in a number of different ways; before starting, prepare the machine based on how the lawn is to be mowed.

a. Prepare the machine for cutting and lateral grass discharge (for models with side discharge only):

Always make sure that the spring inside the deflector (Fig. 6.B) and the safety lever (Fig. 7.B, 8.B) operate correctly, holding it firmly in the lowered position.

b. Pre-set for cutting and chopping grass in the grass catcher (only for models with rear grass catcher "I" and "II")

Hook the grass catcher (fig. 16.A) to the supports (fig. 16.B) and centre it with respect to the rear plate. Centring is ensured by using the right support as a lateral support. Make sure that the lower pipe of the grass catcher opening is attached to the pawl (fig. 16.C).

c. Pre-set for grass cutting and rear grass discharge on the ground (only for models with rear grass catcher)

If you decide to work without the grass catcher, a rear discharge guard kit is available upon request (fig. 17; par 16.5) which must be securely mounted on the rear plate as indicated in the instructions provided.

d. Pre-set for cutting and chopping grass

If you decide to mow grass, mulch it and leave it on the lawn, a "mulching" kit is available upon request (chap. 16.1). This has to be attached to the rear plate as indicated in the instructions.

7.1.5 Positioning the anti-scalping wheels

The anti-scalping wheels are used to reduce the risk of tearing up sections of lawn, which can occur when the edge of the cutting means assembly drags over irregular ground. Position the wheels as indicated (par. 8.3).

7.2 SAFETY CHECKS

Run the following safety checks and ensure that the results correspond to those outlined in the tables.



SAFETY INSTRUCTION

Always perform safety checks before use.



7.2.1 General safety check

Object	Result
Battery	No damage to casing and cover.
Rear discharge protection, grass catcher (only for models with rear grass catcher)	Good condition. No damage. Properly installed.
Side discharge protection (for models with side discharge only)	Good condition. No damage. Properly installed .
Electrical cables	All insulation intact. No mechanical damage.
Operate the machine forwards/reverse and release the drive pedal.	The machine slows down and stops.
Safety devices	Proceed as indicated in par. 7.2.2

7.2.2 Control of safety devices

The safety devices work in two ways:

- A. they prevent the electric engine from starting if all the safety requirements have not been met;
- B. by stopping the electric engine if even just one of the safety requirements is lacking.

Status	Action	Result
Operator seated. Drive pedal in neutral position (pedal released). Emergency button deactivated.	Fully insert the key	The machine is ready to be turned ON.
Machine on or in operation.	The operator stands up from the seat.	All services are deactivated. The icon in fig. 13.E icon flashes and the icon in fig. 13.P is illuminated. 
Operator seated. Drive pedal in forward or reverse position.	Try to start the machine.	The icons in fig. 13.E and fig. 13.O remain ON, battery LEDs 1, 2, 4 and 5 flash. Pushbutton panel of type "I" e "II" 
Emergency button activated.	Attempt to start the machine.	The machine switches ON. The icon in fig. 13.E flashes and the icon in fig. 13.O is illuminated. Drive and cutting means do not work. 
Cutting means engaged.	Reverse is activated without holding down the reverse mowing consent button.	The cutting means disengage.
Cutting means engaged.	Lift the grass catcher or remove the rear discharge guard (for rear collection models only)	The cutting means disengage.
Machine ON and Operating.	Release the drive pedal.	The machine slows down and stops.
Machine ON and Operating.	Test drive.	No unusual vibrations, no unusual sound, correct operation of the steering, controls and pedals.

 **DANGER**

If any results do not to match the indications in the tables, do not use the machine!
Contact an Authorised Service Centre to have it checked and repaired if necessary.

NOTE

Always bear in mind that the safety devices prevent the electric engine from starting if safety requirements have not been met. In such cases, once start-up consent has been reset, remove the key before starting the machine again.

7.3 USING ON SLOPES

Comply with the limits indicated in the "Technical Data" Tables as in "fig. 18" regardless of the mowing direction.

Remember there is no such thing as a "safe" slope. Driving on grass slopes requires particular care. To prevent overturning or loss of control over the machine:

- Never mow across the face of the slope. Lawns on slopes must be mowed by moving up and down and never across them in forward gear. When changing direction, take great care that the wheels facing the slope do not hit any obstacles (such as stones, branches, roots, etc.) that may cause the machine to slide sideways, tip over or make you lose control.
- Do not stop or start suddenly when going up or downhill;
- Shift to drive gear very gently paying particular attention to prevent the machine from tipping up.
- Reduce speed:
 - before changing direction and during tight turns
 - before tackling a slope, especially downhill, to ensure a safe braking distance.
- Never switch to reverse gear to decrease speed when going downhill: this could cause loss of control of the machine, especially on slippery ground.

7.4 START-UP

To start the machine:

1. Check that the transmission is engaged (par. 6.3).
2. Sit in the operator's position.
3. Fully insert the key (fig. 12.A).
 - a. **For models type "I" and "II":**
4. Wait for the machine's electrical check to be performed, during which the icons on the pushbutton panel will flash.
5. Press the power button (Fig. 13.A).
6. Wait until the "Ready" icon (fig. 13.K) is ON steady.

NOTE

At the end of the electrical check, the headlights light up for a moment.

7.5 OPERATION

7.5.1 Drive and transfers

When moving the machine:

1. disengage the cutting means (fig. 13.B);
2. bring the cutting means assembly to the highest position;
3. Press the drive pedal to move the machine in the required direction of driving and set the required speed by adjusting the pressure on the pedal.
4. Go to the work area.

DANGER

Drive must be engaged in accordance with the modes described (paragraph 6.2) to avoid sudden meshing, jerking start and loss of control of the vehicle, especially on slopes.

NOTE

Reverse must only be engaged when the machine has stopped.

7.5.2 Grass cutting

1. Set the cutting means assembly to the work position (par. 6.4).
2. Engage the cutting means (fig.13.B) only on grass lawns; do not engage them on stony ground or when the grass is very high.
3. When starting to cut grass, start off slowly and carefully.
4. Adjust speed and cutting height (par. 6.4) in relation to lawn conditions (grass height, density and humidity) and the amount of grass to be cut.

NOTICE

The forward work speed decreases if the battery charge threshold falls below 40% (par. 8.2.3).

NOTE

The appearance of the lawn will be improved if the grass is always cut at the same height and in two alternating directions (fig. 20).

NOTE

To proceed in reverse gear with the cutting means engaged, press and hold the consent button (fig 13.C) so that the motor does not stop.

Disengage the cutting means and move the cutting means assembly to the highest position:

- When moving between work areas
- When driving on grass free surfaces
- Every time it is necessary to overcome an obstacle.

7.5.3 Suggestions for maintaining a nice lawn

- To keep a lawn green and soft with a good appearance, it should be cut regularly. A lawn can be composed of different types of grass. If the lawn is cut frequently, grass and roots grow more vigorously, forming a solid grassy bed; if the lawn is cut is less frequently, higher grass and weeds start growing (clover and daisies, etc.).
- It is always better to cut the grass when dry.
- The cutting means must be in good condition and well sharpened so that the grass is cut straight without a ragged edge that leads to yellowing at the ends.
- The frequency of mowing should be in relation to the rate of growth of the grass, which should not be left to grow too much between one cut and the next.
- During hot and dry periods, the grass should be cut a little higher to prevent the ground from drying out.
- The best height of the grass on a well-kept lawn is approx. 4-5 cm and with one mowing, you do not need to remove more than one third of the total height. If the grass is very tall, it should be cut twice in a twenty-four hour period; The first time with the cutting means at maximum cutting height and if necessary with open trail and the second cut at the height desired.
- The lawn will have a better appearance if the cuts are made by alternating them in both directions (fig. 20).
- If the discharge chute tends to get blocked with grass, you should reduce the forward speed as it may be too high for the condition of the grass. If the problem persists, the probable causes are either badly sharpened cutting means or deformed fins.
- Be very careful when mowing near bushes or kerbs as these could distort the horizontal position of the cutting means assembly and damage its edge as well as the cutting means.

7.5.4 Emptying of the grass catcher (for rear collection models only)

NOTE

The grass catcher can only be emptied with the cutting means disengaged, otherwise the machine turns off.

NOTE

Do not let the grass catcher become too full as this may block the discharge chute.

A continuous buzzer indicates when the grass catcher is full: Proceed as follows:

1. Disengage the cutting means (par.13.B) and the audible signal will stop;
2. Stop the machine.
a. For models type "I" and "II":
3. Extract the lever (fig. 21.A - if available) or grasp the rear handle (fig. 21.A1) and overturn the grass catcher to empty it.
4. Move the machine about 1 m.
5. Close the grass catcher again so that it remains coupled to the pawl (fig. 21.B).

7.5.5 Cleaning the discharge chute (for rear collection models only)

Cutting very tall or wet grass, particularly at excessively high speed, can clog up the discharge chute. If it clogs, follow the instructions provided in par. 8.4.2.

7.5.6 Mowing completed

When mowing has been completed:

1. disengage the cutting means;
2. turn around with the cutting means assembly in its highest position. (par. 6.4)

7.6 STOP

To stop the machine:

1. Release the drive pedal to stop the drive gear.
 2. Turn off the machine by removing the key.
-

NOTE

To save battery power, do not leave the key in the "run" position when the machine is not in use.

7.7 AFTER USE

1. Allow the machine to cool before storing it in an enclosed space.
2. Clean (par. 8.4).
3. Make sure there are no loose or damaged components. If necessary, replace the damaged components and tighten any screws and loose bolts or contact the authorised service centre.
4. Position the machine near to a power socket and charge the battery (par. 8.2.2) so that it is ready to be used when next required.

Whenever the machine is left unattended, the operator leaves the driving seat or parks the machine:

1. Stop the machine;
2. bring the cutting means assembly to the lowest height position (1)
3. make sure that all moving parts have come to a complete stop;
4. remove the ignition key.

ATTENTION

Always leave the machine in a shaded area or sheltered environment at a temperature below +35°C.

8. ROUTINE MAINTENANCE

8.1 GENERAL INFORMATION

DANGER

The safety regulations to follow are described in chap. 2. Strictly comply with these instructions to avoid serious risks or hazards.

Before commencing any inspections, cleaning or maintenance/adjustments on the machine:

1. disengage the cutting means;
2. stop the machine;
3. make sure that all moving parts have come to a complete stop;
4. Remove the key from the ignition;

DANGER

Never leave the key inserted or within reach of children or inappropriate people.

5. read the relevant instructions;
6. use suitable clothing, protective gloves and goggles.

The frequency and type of procedures are outlined in the "Maintenance table". The table will help you maintain your machine's safety and performance. It summarises the main interventions to be made and the frequency applicable to each of them. Carry out the relevant task as soon as it is scheduled to be performed. The use of non-genuine and/or incorrectly assembled spare parts and attachments could adversely affect machine operation and safety. The manufacturer shall decline all liability in the event of injuries or damages caused by such parts. Genuine spare parts are supplied by Authorised Assistance Centres and Dealers.

8.2 BATTERY

8.2.1 Battery power reserve

Battery life (and therefore the area of lawn that can be mowed before recharging) is essentially affected by:

- A. Work factors involving higher energy requirement (e.g. cutting with dense, tall, humid grass).
- B. Operator behaviour that should be avoided:
 - switching the machine on and off frequently whilst working;
 - Setting a cutting height that is too low for the lawn conditions;
 - Working at a speed that is too high for the amount of grass to be removed.
- C. Environmental factors, such as a high ambient temperature, above +35 °C.

To optimize the life of

the batteries, it is always advisable to:

- Cut the grass when the lawn is dry;
- Cut the grass frequently so that it doesn't grow too tall;
- Set a higher cutting height when the grass is very tall, then set a lower height and cut the lawn again;
- Do not use the machine in "mulching" mode with very high grass.
- cut the grass at a temperature between +5 and +35 °C;
- Use of the "ECO" mode (par. 6.9.2).

8.2.2 Charging the batteries on board the machine

IMPORTANT *Charging must be done exclusively using the battery charger (fig. 23.A). Other charging systems may irreparably damage the battery.*



The single battery cannot be recharged on board the machine.

To recharge the batteries on board the machine:

1. Move the machine to a power outlet and remove the key (fig. 12.A);
2. Raise the seat;
3. Lift the charging port cap (fig. 22.A);
4. Connect the supplied battery charger to the charging port (fig. 23.A) using the appropriate bayonet connector (fig. 23.B);
5. Connect the battery charger to the mains socket by inserting the corresponding plug (fig. 24).

During recharging, the battery indicator LEDs (fig. 13.F) flash progressively. When each individual charge threshold is reached, the respective LED remains lit steadily, while the others continue to flash.

8.2.3 Charging the batteries outside the machine

IMPORTANT *The battery can be recharged independently using the same charger used to recharge the machine:*

1. Remove the battery from the vehicle (fig. from 34 to 37);
2. Place the battery in a dry, safe and stable location;
3. Remove the rubber protective cap from the connector;
4. Connect the charger to the mains socket by inserting the appropriate plug;
5. Connect the supplied battery charger to the battery charging socket, using the appropriate bayonet to secure the respective connector Refer to the battery's user manual.

IMPORTANT *While charging, all machine functions are disabled, even when the key is fully inserted.*

The energy required for operating the machine is provided by a battery which requires careful maintenance to ensure efficiency and a long service life. The machine battery must always be charged:

- Before using the machine for the first time after purchase;
- When the minimum state of charge is reached (Fig. 13 F).
- Before any prolonged period when the machine is not in use
- At least once a month during storage.
- Before starting up the machine after a prolonged period of inactivity.

⚠ ATTENTION

When the battery is not connected to the mains network with the specific battery charger, battery charge will be lost even if the battery

is not used. If the battery is subject to a deep discharge, it could be seriously damaged to the point that it can no longer be used. The warranty does not cover damage caused by a battery not having charged correctly.

⚠ ATTENTION

Charging must take place exclusively via the battery charger (fig. 23.A). Other recharging systems can irreversibly damage the battery.

⚠ ATTENTION

The batteries must only be charged in an area protected against poor weather conditions, in the shade, at a recommended temperature of between +5 e +35 °C.

NOTE

The battery can be charged at any time, even partially, with no risk of damaging it.

⚠ SAFETY INSTRUCTION

Do not carry out maintenance or cleaning operations while the battery is charging.

To charge the battery, a socket with a differential safety switch (Fig. 25.A) is supplied (where required) to which the charge cable (Fig. 25 E) must be connected.





- The socket with the differential safety switch must be connected to the mains power network and an operating test must be carried out:
1. Press the "RESET" button (Fig. 25 BA) to activate operation. The indicator light must be "ON" (Fig. 25.C).
 2. Press the "TEST" button (Fig. 25.D) to perform the operating test. The indicator light must be "OFF" (Fig. 25.C).

⚠ DANGER

If the operating test is not completed successfully, the socket with the differential switch must not be used. If the operating test is completed successfully, it can be used and the operator can proceed with the charging stage.

The complete recharge takes about 2-8.5 hours (depending on the battery and the battery charger), during which the signalling LEDs (fig. 13.F) flash progressively. When each individual charge threshold is reached,

the respective LED remains lit steadily, while the others continue to flash. The battery can be kept in charge mode for an indefinite period of time.

Charge status (SOC)	Led lighting (type "I" and "II")
SOC > 80%	
60% ≤ SOC < 80%	
40% ≤ SOC < 60%	
20% ≤ SOC < 40%	
10% ≤ SOC < 20%	

NOTICE

Battery charging times may increase if the machine has been used in heavy-duty work conditions with consequent indication of battery overheating (chap. 15).

NOTICE

If a battery becomes completely discharged, the signalling LEDs remain off until the minimum charge threshold is reached.

NOTE

When the charge level drops below the 10% threshold, the first battery LED begins flashing. The cutting means are disengaged and the battery must be re-entered and recharged.

NOTICE

If, when the battery charger is connected to the tractor, the 5 LEDs fig. 13.F all flash at the same time, it means charging is not in progress. Check the battery charger/mains connection.

NOTE

Energy consumption to maintain the battery charge is extremely low with negligible cost.

NOTE

While charging, all machine functions are disabled, even when the key is fully inserted.

8.3 ANTI-SCALPING WHEELS

Thanks to the various mounting positions of the wheels, it is possible to maintain a safety distance "H" between the edge of the cutting means assembly and the ground (fig. 26, fig. 27). Adjust the position of the anti-scalping wheels according to how irregular the ground is.

SAFETY INSTRUCTION

This operation must always be performed on both wheels, positioning them at the same height, with the machine off.

a. For models with side discharge

To change the position:

1. unscrew and remove the screw (fig. 26.B);
2. reposition the small wheel (fig. 26.A) with the spacer (fig. 26.C) in the hole corresponding to the desired distance;
3. fully tighten the screw (fig. 26.B) in the nut (fig. 26.D).

b. For models with rear grass catcher:

To change the position:

1. unscrew the nut (fig. 27.B) and remove the pin (fig. 27.C);
2. Reposition the wheel (fig. 27.A) in the desired position
3. reassemble the pin (fig. 27.C), making sure that the head of the pin (fig. 27.C) is facing the inside of the machine;
4. fully tighten the nut (fig. 27.B).

8.4 CLEANING

Clean thoroughly following the instructions below every time it is used.

8.4.1 Cleaning the machine

- Clean the outside of the machine washing the plastic parts of the bodywork with a damp sponge using water and detergent, taking care not to wet the electric motors, the battery or the parts of the electrical system.
- To reduce fire hazards, keep the engine and the battery housing free of grass, leaves, or excessive grease.
- Lift the hood and clean with compressed air any dirt or grass residues that accumulate on top of the battery pack.

- Keep the pushbutton panel free of dirt and debris.

ATTENTION

Never use high pressure water or aggressive fluids to wash the bodywork and electric motors.

ATTENTION

Never use liquids for cleaning the transmission system, batteries and electronic components (fig. 30, fig. 31). To clean them, blow with a jet of compressed air.

8.4.2 Cleaning the discharge chute (for rear collection models only)

If the discharge chute is clogged:

1. remove the grass catcher or the rear discharge guard;
2. remove the grass cuttings; you can reach them from the chute discharge opening.

8.4.3 Cleaning the grass catcher (only for rear grass catchers of type "I" and "II")

1. Empty the grass catcher (par. 7.5.4).
2. Shake it to remove grass cuttings and soil residue.
3. Replace the grass catcher and clean the interior of the cutting means assembly (par. 8.4.4-a), now remove the grass catcher, empty and rinse it, then place it where it can dry quickly.

8.4.4 Cleaning the cutting means assembly

Clean cutting means assembly thoroughly to remove any grass residue or debris.

WARNING

Keep people or animals away from the surrounding area when cleaning the cutting means assembly.

a. Cleaning the interiors

When washing the inside of the cutting means assembly and the discharge chute, the machine must be on firm ground with:

- the grass catcher or the rear discharge guard mounted in place (for rear collection models only)
- the side discharge chute mounted (for models with side discharge only);
- the operator seated;

- the cutting means assembly in the lowest position;
- the transmission in neutral;
- the cutting means engaged;

- Alternatively, connect a water tube to the dedicated coupling (fig. 28.A), allowing water to flow through each cutting means for a few minutes, while they are in motion.

b. Cleaning the exterior

SAFETY INSTRUCTION

Do not allow debris and dried grass to accumulate in the upper part of the cutting means assembly in order to maintain maximum machine efficiency and safety levels.

To clean the upper part of the cutting means assembly:

- fully lower the cutting means assembly;
- blow with a jet of compressed air (fig. 29).

8.5 LUBRICATION

Object	Action
Steering wheel	Clean with compressed air.
Cutting means assembly	Lubricate the lifting points with oil (fig. 38).
Wheel axles	Remove the wheels. Lubricate the axles with grease (Fig. 46).

8.6 NUTS AND BOLTS

- Keep all nuts, bolts and screws tight to be sure the equipment is in safe working condition.

9. EXTRAORDINARY MAINTENANCE

9.1 SAFETY RECOMMENDATIONS

SAFETY INSTRUCTION

You must immediately contact your Authorised Service Centre or Dealer if the following malfunctions are found:

- the neutral position of the drive pedal (service brake)
- cutting means engage and disengage functions
- switching the drive to forward or reverse gears.

9.2 CUTTING MEANS ASSEMBLY / CUTTING MEANS

9.2.1 Aligning the cutting means assembly

The cutting means assembly should be properly adjusted to obtain an evenly mown lawn (fig. 19). If mowing is uneven, check the tyre pressure (par. 7.1.3). If this is not sufficient to achieve an even cut, please contact your Dealer to adjust the alignment of the cutting means assembly.

9.2.2 Cutting means

Badly sharpened cutting means pull at the grass and cause the lawn to turn yellow.

SAFETY INSTRUCTION

Always replace damaged, bent or worn pairs of cutting means, together with their nuts and bolts, in order to maintain their balance.

WARNING

All work on the cutting means (disassembly, sharpening, balancing, repairing, reassembly and/or replacing) are demanding jobs that require special skills as well as special tools; For safety reasons, these jobs are best carried out at a Authorised Service Centre.

ATTENTION

Always use original cutting means bearing the code indicated in the "Technical Data".

NOTE

Given product evolution, the cutting means listed in the "Technical Data" table may be replaced in time with others having similar interchangeable and operating safety features.

9.3 REPLACING FRONT / REAR WHEELS

9.3.1 Preliminary operations

DANGER

Use a suitable lifting device.

Before changing the wheels it is necessary to complete some preliminary operations:

1. Position the machine on a solid and even surface that guarantees stability of the machine.
2. Stop the machine;
3. Remove the key from the ignition;
4. Position the lifting device in the lifting position near the wheel to be changed (par. 9.3.2; par. 9.3.3).
5. Check that the lifting device is perfectly perpendicular to the ground.

9.3.2 Choice and positioning of the jack on the rear wheels

Position some wooden wedges (fig. 39.A) at the base of the wheel (fig. 39.B) next to the wheel to be changed (fig. 39.C).

For models with rear collection:

- The maximum possible jack height when closed is 110 mm. (fig. 40).
- Position the jack under the rear plate (fig. 41.A) at 180 mm from the side edge (fig. 40).

For side discharge models:

- The maximum possible jack height when closed is 110 mm. (fig. 42).
- Position the jack under the rear axle, in the point indicated in the diagram (fig. 43.A).

NOTE

In this position the jack allows you to raise only the wheel to be changed.

9.3.3 Choice and positioning of the jack on the front wheels

1. Position some wooden wedges (fig. 44.A) at the base of the wheel (fig. 44.B) behind the wheel to be changed (fig. 44.C).
2. The maximum possible jack height when closed is 110 mm.
3. Place on top of the jack (fig. 45.A) a squared piece of wood (fig. 45.B) having a cross-section of about 10 x 10 cm.

ATTENTION

The thickness of the wood prevents damage to the front axle.

4. During this stage, keep the wooden pad balanced on the jack with one hand. Lift the jack making sure that the wooden pad rests against the frame and the structural parts (fig. 45.C).

NOTE

The jack positioned in this way makes it possible to lift the entire front axle.

9.3.4 Changing the wheel

SAFETY INSTRUCTION

Make sure that the machine remains still and stable during the lifting process. If you notice anything out of the ordinary, lower the jack immediately, check and resolve any problems and lift the machine again.

1. Remove the cover (fig. 46.A).
 2. Raise it enough to extract the wheel easily.
 3. Use a screwdriver to remove the snap ring (fig. 46.B) and the shoulder washer (fig. 46.C).
 4. Remove the wheel to be changed.
 5. Smear the axle (fig. 46.D) with grease.
 6. Mount the spare wheel.
 7. Carefully replace the shoulder washer and snap ring.
-

NOTE

Check that the two rear wheels are the same height (fig. 47.A) and that the difference between the external diameters of the two wheels (fig. 47.B) is no greater than 8-10 mm. On the contrary, to avoid uneven mowing, the cutting means assembly must be aligned by an Authorised Service Centre.

9.3.5 Repairing or changing tyres

The tyres are "Tubeless" and so all punctures must be repaired by a tyre repairer following the procedures required for this type of tyre.

10. STORAGE

When you intend to put your machine away for more than 30 days:

1. Remove the ignition key.
2. Clean the machine thoroughly.
3. Check the machine for any damage. If necessary, contact the authorised service centre.
4. Store the machine:
 - with the cutting means assembly lowered
 - in a dry place;
 - protected against poor weather conditions, at a recommended temperature of between 0 and +40 °C.
 - covered with a sheet if possible;
 - in a place out of children's reach;

- making sure that keys or tools used for maintenance are removed.

ATTENTION

Make sure that the battery is fully charged at least once a month and always before use.

When re-starting the machine, set it up as indicated in chapter "7. "Using the machine".

11. HANDLING AND TRANSPORT

- When handling the machine, always:
 1. disengage the cutting means;
 2. bring the cutting means assembly to the highest position;
 3. switch off the machine and remove the ignition key
 4. disengage the drive (par.6.3).
- When transporting the machine on a vehicle or trailer, always:
 - use an access ramp of suitable strength, width and length;
 - load the machine with the electric motor switched off, with the key removed from the ignition, without a driver and pushed by an adequate number of people;
 - lower the cutting -device assembly;
 - position it so that it does not cause a hazard to anyone;
 - engage the drive (par.6.3).
 - lock it firmly on the means of transport using ropes or chains to prevent it from tipping over and possible damage.

SAFETY INSTRUCTION

If you feel unable to carry out handling or transport in safe conditions, contact the Service Centre.

12. ASSISTANCE AND REPAIRS

This manual provides all the necessary information to run the machine and for correct basic maintenance operations which can be performed by the user. Any regulations and maintenance operations not described herein must be carried out by your Dealer or Authorised Service Centre, which have the necessary knowledge and equipment to ensure that the work is carried out correctly, maintaining the correct degree of safety and the original operating conditions of the machine. Any operations performed in unauthorised centres or by unqualified persons will totally

invalidate the warranty and all obligations and responsibilities of the manufacturer.

- Only Authorised Service Centres can carry out guaranteed repairs and maintenance.
- The Authorised Service Centres only use genuine spare parts. Genuine spare parts and attachments have been designed specifically for machines.
- Non-original parts and attachments are not approved; use of non-original spare parts and attachments will jeopardise the safety of the machine and relieve the Manufacturer from all obligations or liabilities.
- It is advisable to send your machine once a year to an Authorised Service Centre for servicing, assistance and safety device inspection.

13. WARRANTY COVERAGE

The warranty conditions are intended for consumers only, i.e. non-professional operators. The warranty covers all material quality and manufacturing defects recognised during the warranty period by your Dealer or Authorised Service Centre. The warranty is restricted to the repair or replacement of components recognised as faulty. The warranty only applies to machines subjected to regular maintenance. The user must follow all the instructions provided in the accompanying documentation. The warranty does not cover damages resulting from:

- Failure to become familiar with the documentation accompanying the machine (Instruction manual).
- Professional use.
- Carelessness, negligence.
- External causes (lightning, impact, presence of foreign bodies inside the machine) or incidents.
- Incorrect use or assembly or prohibited by the manufacturer.
- Poor maintenance.
- Modification to the machine.
- Use of non-genuine spare parts (adaptable parts).
- Use of attachments not supplied or not approved by the manufacturer.

The warranty does not cover:

- The routine/occasional maintenance operations (described in the owner's manual).
- Normal wear and tear of consumables such as cutting means, wheels, beacons, safety bolts and wiring.
- Normal wear and tear.
- Deterioration in the appearance of the machine due to use.
- Cutting means supports.
- Any accessory expenses related to the enforcement of the warranty, such as costs incurred to travel to the user's location, transfer of the machine to the Dealer, rental of replacement equipment or calling of independent enterprises to perform maintenance work.

The user is protected by his or her own national legislation. The purchaser's rights under the national laws or his or her own country are not in any way restricted by this warranty.

14. MAINTENANCE TABLE

Use the boxes at the side to note the date or number of operating hours when the intervention was performed.





Intervention	Frequency (hours)	Performed (Date or Time)					Notes
Check all fasteners	Before each use						
Tyre pressure check	Before each use						para. 7.1.3
Safety checks/check controls	Before each use						par. 7.2
Check the drive release lever	Before each use						para. 6.3
Assembly / Check of the protections at the exit	Before each use						para. 5.5
Charging the battery	Before each use After each use Before storage						par. 8.2
General cleaning and inspection	After each use						para. 8.4
Checking for any damage to the machine. If necessary, contact the authorised service centre.	After each use						
Cutting means positioning and sharpening check	25						*
Replacing cutting means	100						*
General lubrication	25						par. 8.5 **





* This operation must be carried out by your Dealer or an Authorised Service Centre.

** General lubrication of all joints should also be carried out whenever the machine is to be left unused for a long period

15. TROUBLESHOOTING

PROBLEM	Cause	Remedy
1. The machine will not switch on.	Low battery.	Charge the battery (par. 8.2.2).
2. Irregular cutting	Cutting means sharpening is reduced.	Contact an Authorised Service Centre Authorized.
	High forward speed in relation to the height of the grass to be cut. Cutting means assembly full of grass.	Reduce forward speed and/or Increase the cutting height: Wait for the grass to dry. Clean the cutting means assembly.
3. Unusual vibrations during use.	Cutting means incorrectly balanced.	Contact an Authorised Service Centre authorized for verification, replacements or repairs.
	Cutting means loose.	
	Loose parts.	
	Possible damage	

PROBLEM	Cause	Remedy
<p>4. The icon in fig. 13.E remains ON and battery LEDs 2 and 5 flash.</p> <p>Pushbutton panel type "I" and "II"</p> 	<p>Battery current overload caused by:</p> <ol style="list-style-type: none"> 1. Work conditions too demanding. 2. Slope too steep . 	<p>Reduce forward speed: Increase the cutting height:</p> <p>Reduce the forward speed and check the slope of the ground where you are working.</p>
<p>5. The icon in fig. 13.N flashes. All the other indications in the push-button panel (icons/LEDs) remain functional and visible.</p> 	<p>Pre-alarm for battery, drive motor and/or cutting means motor over-temperature because of:</p> <ol style="list-style-type: none"> 1. Work conditions too demanding. 	<p>Reduce forward speed: Increase the cutting height:</p>
<p>6. The icons in fig. 13.E and fig. 13.O remain ON, battery LEDs , 2, and 4 flash.</p> <p>Pushbutton panel type "I" and "II"</p> 	<p>Battery over/under temperature caused by:</p> <ol style="list-style-type: none"> 1. Work conditions too demanding. 2. Unsuitable environmental conditions. 	<p>Turn off the machine, wait for at least 5 minutes and then restart it.</p> <p>Reduce forward speed: Increase the cutting height:</p> <p>Work in an environment with a temperature appropriate for the machine's operating conditions.</p>
<p>7. The icon in fig. 13.E remains ON and battery LEDs 1, 4 and 5 flash.</p> <p>Pushbutton panel type "I" and "II"</p> 	<p>Current overload to cutting means caused by:</p> <ol style="list-style-type: none"> 1. Work conditions too demanding. 2. Obstructions that prevent rotation of the cutting means. 3. The cutting means assembly is full of grass 	<p>Reduce forward speed: Increase the cutting height:</p> <p>Remove the obstructions.</p> <p>Clean the cutting means assembly:</p>
<p>8. The icons in fig. 13.E and fig. 13.O remain ON, battery LEDs 1 and 3 flash.</p> <p>Pushbutton panel type "I" and "II"</p> 	<p>Cutting means motor over-temperature caused by:</p> <p>Work conditions too demanding.</p>	<p>Turn off the machine, wait for at least 5 minutes and then restart it.</p> <p>Reduce forward speed: Increase the cutting height:</p>

PROBLEM	Cause	Remedy
<p>9. The icon in fig. 13.E remains ON and battery LEDs 1, 3 and 5 flash.</p> <p>Pushbutton panel type "I" and "II"</p> 	<p>Cutting means motor stall caused by:</p> <ol style="list-style-type: none"> 1. Work conditions too demanding. 2. Obstructions that prevent rotation of the cutting means. 3. The cutting means assembly is full of grass 	<p>Reduce forward speed: Increase the cutting height:</p> <p>Remove the obstructions.</p> <p>Clean the cutting means assembly:</p>
<p>10. The icons in fig. 13.E and fig. 13.O remain ON, battery LEDs 1, 2 and 4 flash.</p> <p>Pushbutton panel type "I" and "II"</p> 	<p>Drive motor over-temperature caused by.</p> <ol style="list-style-type: none"> 1. Drive motor under stress. 2. Slope too steep . 3. Excessive mud on the wheels. 	<p>Switch off the machine and wait for at least 5 minutes before repeating the starting procedure.</p> <p>Reduce forward speed:</p> <p>Reduce speed and check the slope of the ground where you are working.</p> <p>Make sure that the wheels are not blocked and clean as needed.</p>
<p>11. The icons in fig. 13.E and fig. 13.O remain ON, battery LEDs 1, 2, 4 and 5 flash.</p> <p>Pushbutton panel of type "I" e "II"</p> 	<p>The machine starts with the drive pedal not released (not in neutral position).</p>	<p>Switch off the machine and repeat the starting procedure only after having checked that the drive pedal is in the neutral position (pedal released).</p>
<p>12. The icons in fig. 13.E and fig. 13.O remain ON, battery LEDs 1, 2, 3 and 5 flash.</p> <p>Pushbutton panel type "I" and "II"</p> 	<p>Drive engagement/disengagement lever in drive disengaged position.</p>	<p>Check the position of the drive engagement/disengagement lever and, if necessary, return it to the drive engaged position.</p> <p>If the problem persists, contact a Service Centre.</p>
<p>13. The battery LEDs in fig. 13.F turn ON and OFF in sequence, from left to right, and vice versa.</p>	<p>Communication error between on-board electronic modules.</p>	<p>Switch off the machine and repeat the starting procedure</p> <p>If the problem persists, contact a Service Centre.</p>

NOTE

For any further problems not listed in the table, immediately contact an Authorized Assistance Centre.

16. ATTACHMENTS

16.1 "MULCHING" KIT

It finely chops the grass cuttings and leaves them on the lawn (fig. 49.A1; fig 49.A2).

16.2 BATTERY CHARGER (FAST CHARGE)

This battery charger helps reduce battery recharging time. The list of type-approved battery chargers for this machine can be found in the "Technical Data" table. This keeps the battery in good working order when the machine is in storage, guaranteeing an optimum level of charge and longer battery life (fig. 49.B).

16.3 TOWING KIT

To tow a small trailer (fig. 49.C).

16.4 CANVAS COVER

Protects the machine from dust when not in use (fig. 49.D)

16.5 REAR DISCHARGE GUARD KIT

Can be used in place of the grass catcher when mown grass is not collected (Fig. 49.A) (Only for models with rear grass catcher).

16.6 SNOW CHAINS

Improved adherence of the rear wheels on the snow-covered sections and possibility of using snow ploughs (Fig. 49.F).

16.7 MUD / SNOW WHEELS

Improve drive performance on snow and mud (Figure 49.G).

16.8 TRAILER

To transport tools or tall objects within permitted load limits (Fig. 49.H).

16.9 SPRINKLER

To spread salt or fertilizers (Fig. 49.I).

16.10 SNOW SHOVEL

For clearing and accumulating removed snow at sides (Fig. 49.J).

DICHIARAZIONE CE DI CONFORMITÀ (Istruzioni Originali)
(Direttiva Macchine 2006/42/CE, Allegato I), paragrafo A)

- La Società: ST S.p.A. – Via del Lavoro, 6 – 31033 Castelfranco Veneto (TV) – Italy
- Dichiara sotto la propria responsabilità, che la macchina:
(Tesaerba con conduttore a bordo seduto (taglio erba))

e) Tipo / Modello Base: MP84 LJ 55 V1
c) Numero di Serie: 25A*FON000001 + 99L*FON899999
d) Motore: a batteria

3. È conforme alle specifiche delle direttive:

- MD: 2006/42/EC
- OND: 2000/14/EC, ANNEX VI - 2005/98/EC - (EU) 2024/1208

e) Ente certificatore:

N. 0197 – TÜV Rheinland LGA Products GmbH
Tillystrasse 2, 90431 Nurnberg – Germany

- EMC/D: 2014/30/EU
- RoHS II: 2011/65/EU - 2015/863/EU
- RED: 2014/53/EU

4. Riferimento alle norme armonizzate:

EN IEC 55014-2:2021
EN 62841-1:2015 + AC:2016 + A11:2022
EN ISO 5395-1:2013 + A1:2018
EN ISO 5395-3:2013 + A1:2017 + A2:2018
EN IEC 55014-1:2021
EN 301489-1 V2.2.3
EN 301489-1 V3.2.4

- Livello di potenza sonora misurato:
- Livello di potenza sonora garantito:
- Ampliezza di taglio:

98,21 dB(A)
99 dB(A)
84 cm

n) Persona autorizzata a costruire il Fascicolo Tecnico:

ST S.p.A.
Via del Lavoro, 6
31033 Castelfranco Veneto (TV) - Italia

o) Castelfranco Veneto, 30/09/2025

CEO Stiga Group
Sean Robinson



1715127630

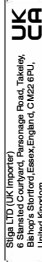

1715127630

UK DECLARATION OF CONFORMITY

(Supply of Machinery (Safety) Regulations 2008, SI. 2008 No. 1597, Annex II, part A)

- The company: ST S.p.A. – Via del Lavoro, 6 – 31033 Castelfranco Veneto (TV) – Italy
- Hereby declares under its own responsibility, that the machine:
(Idle-on lawnmower with seated operator (grass cutting))

a) Homologation type: MP84 LJ 55 V1
c) Serial number: 25A*FON000001 + 99L*FON899999
d) Engine: battery-operated

3. Conforms to UK Regulations:

- SI. 2008/1597 - Supply of Machinery (Safety) Regulations 2008
- SI. 2001/17701 - Schedule 9 - Noise Emission in the Environment by Equipment for use Outdoors Regulations 2001
- Notified body: N. 0197 – TÜV Rheinland LGA Products GmbH
Tillystrasse 2, 90431 Nurnberg – Germany

- SI. 2016/1091 - Electromagnetic Compatibility Regulations 2016
- SI. 2016/3632 - The Restriction of the Use of Certain Hazardous Substances in Electrical and Electronic Equipment Regulations 2012
- SI. 2017/1206 - Radio Equipment Regulations 2017

4. Reference to harmonised standards:

EN 62841-1:2015 + AC:2016 + A11:2022
EN ISO 5395-1:2013 + A1:2018
EN ISO 5395-3:2013 + A1:2017 + A2:2018
EN IEC 55014-1:2021
EN 301489-1 V2.2.3
EN 301489-1 V3.2.4

- Measured sound power level:
- Guaranteed sound power level:
- Cutting width:

98,21 dB(A)
99 dB(A)
84 cm

n) Person authorised to compile the technical file:

ST S.p.A.
Via del Lavoro, 6
31033 Castelfranco Veneto (TV) - Italia

o) Castelfranco Veneto, 30/09/2025

CEO Stiga Group
Sean Robinson



DICHIARAZIONE CE DI CONFORMITÀ (Istruzioni Originali)
(Direttiva Macchine 2006/42/CE, Allegato II, paragrafo A)

- La Società: ST S.p.A. – Via del Lavoro, 6 – 31033 Castelfranco Veneto (TV) – Italy
- Dichiara sotto la propria responsabilità, che la macchina:
Tosaerba con conduttore a bordo seduto (taglio erba)

a) Tipo / Modello Base: MP98 L 56 V2
c) Numero di Serie: 25A*RON00001 + 99L*RON99999
d) Motore: a batteria

3. È conforme alle specifiche delle direttive:

- MD: 2006/42/EC
- OND: 2000/4/EC, ANNEXXI - 2005/69/EC - (EU) 2024/1208

e) Ente certificatore:

N. 0197 – TÜV Rheinland LGA Products GmbH
Tillystrasse 2, 90431 Nürnberg – Germany

- EMC: 2014/30/EU
- RoHS II: 2011/65/EU - 2015/863/EU
- RED: 2014/53/EU

4. Riferimento alle norme armonizzate:

EN IEC 55014-2:2021
EN 62841-1:2015 + AC:2015 + A11:2022
EN ISO 5385-1:2013 + A1:2018
EN ISO 5385-3:2013 + A1:2017 + A2:2018
EN IEC 55014-1:2021
EN 301489-1 V2.2.3
EN 301489-1 V3.2.4

- g) Livello di potenza sonora misurato:
h) Livello di potenza sonora garantito:
i) Ampiezza di taglio:

98,14 dB(A)
100 dB(A)
98 cm

n) Persona autorizzata a costituire il Fascicolo Tecnico:

ST S.p.A.
Via del Lavoro, 6
31033 Castelfranco Veneto (TV) - Italia

o) Castelfranco Veneto, 30/09/2025

CEO Stiga Group
Sean Robinson



1715127640

UK DECLARATION OF CONFORMITY

(Supply of Machinery (Safety) Regulations 2008, SI. 2008 No. 1597, Annex II, part A)

- The company: ST S.p.A. – Via del Lavoro, 6 – 31033 Castelfranco Veneto (TV) – Italy
- Hereby declares under its own responsibility that the machine:
Ride-on lawnmower with seated operator (grass cutting)

a) Homologation type: MP98 L 56 V2
c) Serial number: 25A*RON00001 + 99L*RON99999
d) Engine: battery-operated

3. Conforms to UK Regulations:

- SI. 2008/1597 - Supply of Machinery (Safety) Regulations 2008
- SI. 2001/1701 - Schedule 9 - Noise Emission in the Environment by Equipment for use Outdoors Regulations 2001
- SI. 2017/1206 - Radio Equipment Regulations 2017

N. 0197 – TÜV Rheinland LGA Products GmbH
Tillystrasse 2, 90431 Nürnberg – Germany

- SI. 2016/1091 - Electromagnetic Compatibility Regulations 2016
- SI. 2012/3632 - The Restriction of the Use of Certain Hazardous Substances in Electrical and Electronic Equipment Regulations 2012
- SI. 2017/1206 - Radio Equipment Regulations 2017

4. References to harmonised standards:

EN 62841-1:2015 + AC:2015 + A11:2022
EN ISO 5385-1:2013 + A1:2018
EN ISO 5385-3:2013 + A1:2017 + A2:2018
EN IEC 55014-1:2021
EN 301489-1 V2.2.3
EN 301489-1 V3.2.4

- g) Measured sound power level:
h) Guaranteed sound power level:
i) Cutting width:

98,14 dB(A)
100 dB(A)
98 cm

n) Person authorised to compile the technical file:

ST S.p.A.
Via del Lavoro, 6
31033 Castelfranco Veneto (TV) - Italia

o) Castelfranco Veneto, 30/09/2025

CEO Stiga Group
Sean Robinson



1715127640

DICHIARAZIONE CE DI CONFORMITÀ (Istruzioni Originali)
(Direttiva Macchine 2006/42/CE, Allegato II, paragrafo A)

- La Società: ST S.p.A. – Via del Lavoro, 6 – 31033 Castelfranco Veneto (TV) – Italy
- Dichiara sotto la propria responsabilità, che la macchina:
Tosareba con conduttore a bordo seduto (taglio erba)

a) Tipo / Modello Base: SD98 LI 56 V1
c) Numero di Serie: 25A*RON00001 + 99L*RON999999
d) Motore: a batteria

- È conforme alle specifiche delle direttive:
 - MD: 2006/42/EC
 - OND: 2000/14/EC, ANNEXXI - 2005/68/EC - (EU) 2024/1208

e) Ente certificatore: N. 0197 – TÜV Rheinland LGA Products GmbH
Tillystrasse 2, 90431 Nürnberg – Germany

- EMC-D: 2014/30/EU
- RoHS II: 2011/65/EU - 2015/863/EU
- RED: 2014/53/EU

- Riferimento alle norme armonizzate:
 - EN IEC 55014-2:2021
 - EN 62841-1:2015 + AC:2015 + A11:2022
 - EN ISO 63000:2018
 - EN ISO 5385-3:2013 + A1:2018
 - EN ISO 5385-3:2013 + A1:2017 + A2:2018
 - EN IEC 55014-1:2021
 - EN 301489-1 V2.2.3
 - EN 301489-1 V3.2.4

- Livello di potenza sonora misurato: 98,13 dB(A)
- Livello di potenza sonora garantito: 100 dB(A)
- Ampliezza di taglio: 98 cm

- Persona autorizzata a costituire il Fascicolo Tecnico: ST S.p.A.
Via del Lavoro, 6
31033 Castelfranco Veneto (TV) - Italia

c) Castelfranco Veneto, 30/09/2025
CEO Stiga Group
Sean Robinson



1715127650

UK DECLARATION OF CONFORMITY
(Supply of Machinery (Safety) Regulations 2008, SI. 2008 No. 1597, Annex II, part A)

- The company: ST S.p.A. – Via del Lavoro, 6 – 31033 Castelfranco Veneto (TV) – Italy
- Hereby declares under its own responsibility that the machine:
Ride-on lawnmower with seated operator (grass cutting)

a) Homologation type: SD98 LI 56 V1
c) Serial number: 25A*RON00001 + 99L*RON999999
d) Engine: battery-operated

- Conforms to UK Regulations:
 - SI. 2008/1597 - Supply of Machinery (Safety) Regulations 2008
 - SI. 2001/1701 - Schedule 9 - Noise Emission in the Environment by Equipment for use Outdoors Regulations 2001
 - SI. 2017/1206 - Radio Equipment Regulations 2017

a) Notified body: N. 0197 – TÜV Rheinland LGA Products GmbH
Tillystrasse 2, 90431 Nürnberg – Germany

- SI. 2016/1091 - Electromagnetic Compatibility Regulations 2016
- SI. 2012/3632 - The Restriction of the Use of Certain Hazardous Substances in Electrical and Electronic Equipment Regulations 2012
- SI. 2017/1206 - Radio Equipment Regulations 2017

- References to harmonised standards:
 - EN 62841-1:2015 + AC:2015 + A11:2022
 - EN ISO 5385-1:2013 + A1:2018
 - EN ISO 5385-3:2013 + A1:2017 + A2:2018
 - EN IEC 55014-1:2021
 - EN IEC 55014-2:2021
 - EN IEC 63000:2018
 - EN ISO 63028 V2.2.2
 - EN 301489-1 V2.2.3
 - EN 301489-1 V3.2.4

- Measured sound power level: 98,13 dB(A)
- Guaranteed sound power level: 100 dB(A)
- Cutting width: 98 cm

- Person authorised to compile the technical file: ST S.p.A.
Via del Lavoro, 6
31033 Castelfranco Veneto (TV) - Italia

c) Castelfranco Veneto, 30/09/2025
CEO Stiga Group
Sean Robinson



1715127650

DICHIARAZIONE CE DI CONFORMITÀ (Istruzioni Originali)
(Direttiva Macchine 2006/42/CE, Allegato II, paragrafo A)

1. La Società: ST, S.p.A. – Via del Lavoro, 6 – 31033 Castelfranco Veneto (TV) – Italy
2. Dichiaro sotto la propria responsabilità, che la macchina:
Tosaerba con conduttore a bordo seduto (taglio erba)

a) Tipo / Modello Base: SD108 LI 56 V2
c) Numero di Serie: 25A**RON000001 + 99L**RON999999
d) Motore: a batteria

3. È conforme alle specifiche delle direttive:

- MD: 2006/42/EC
- OND: 2000/14/EC, ANNEX VI - 2005/69/EC - (EU) 2024/1208

e) Ente certificatore:

- N. 0197 – TÜV Rheinland LGA Products GmbH
Tillystrasse 2, 90431 Nürnberg – Germany
- EMC-D: 2014/30/EU
 - RoHS II: 2011/65/EU - 2015/863/EU
 - RED: 2014/53/EU

4. Riferimento alle norme armonizzate:

- EN IEC 55014-2:2021
- EN 62984-1:2015 + AC:2015 + A11:2022
- EN ISO 63000:2018
- EN ISO 5395-3:2013 + A1:2018
- EN ISO 5395-3:2013 + A1:2017 + A2:2018
- EN IEC 55014-1:2021
- EN 301489-1 V2.2.3
- EN 301489-1 V3.2.4

- g) Livello di potenza sonora misurato: 96,59 dB(A)
h) Livello di potenza sonora garantito: 99 dB(A)
i) Ampiezza di taglio: 108 cm

n) Persona autorizzata a costituire il Fascicolo Tecnico:

ST, S.p.A.
Via del Lavoro, 6
31033 Castelfranco Veneto (TV) - Italia

o) Castelfranco Veneto, 30/09/2025

CEO Stiga Group
Sean Robinson



1715127660

UK DECLARATION OF CONFORMITY

(Supply of Machinery (Safety) Regulations 2008, S.I. 2008 No. 1597, Annex II, part A)

1. The company: ST, S.p.A. – Via del Lavoro, 6 – 31033 Castelfranco Veneto (TV) – Italy
2. I hereby declare under its own responsibility that the machine:
Ride-on lawnmower with seated operator (grass cutting)

a) Homologation type: SD108 LI 56 V2
c) Serial number: 25A**RON000001 + 99L**RON999999
d) Engine: battery-operated

3. Conforms to UK Regulations:

- S.I. 2008/1597 - Supply of Machinery (Safety) Regulations 2008
 - S.I. 2001/1701 - Schedule 9 - Noise Emission in the Environment by Equipment for use Outdoors Regulations 2001
 - S.I. 2017/1206 - Radio Equipment Regulations 2017
- e) Notified body:
N. 0197 – TÜV Rheinland LGA Products GmbH
Tillystrasse 2, 90431 Nürnberg – Germany
- S.I. 2016/1091 - Electromagnetic Compatibility Regulations 2016
 - S.I. 2012/3632 - The Restriction of the Use of Certain Hazardous Substances in Electrical and Electronic Equipment Regulations 2012
 - S.I. 2017/1206 - Radio Equipment Regulations 2017

4. Reference to harmonised standards:

- EN 62984-1:2015 + AC:2015 + A11:2022
- EN ISO 5395-1:2013 + A1:2018
- EN ISO 5395-3:2013 + A1:2017 + A2:2018
- EN IEC 55014-1:2021
- EN 301489-1 V2.2.3
- EN 301489-1 V3.2.4

- g) Measured sound power level: 96,59 dB(A)
h) Guaranteed sound power level: 99 dB(A)
i) Cutting width: 108 cm

n) Person authorised to compile the technical file:

ST, S.p.A.
Via del Lavoro, 6
31033 Castelfranco Veneto (TV) - Italia

o) Castelfranco Veneto, 30/09/2025

CEO Stiga Group
Sean Robinson



1715127660

IT • Il contenuto e le immagini del presente manuale d'uso sono stati realizzati per conto di ST. S.p.A. e sono tutelati da diritto d'autore – È vietata ogni riproduzione o alterazione anche parziale non autorizzata del documento.

BG • Съдържанието и изображенията в настоящото ръководство са извършени за ST. S.p.A. и са защитени с авторски права – Забранява се всяко неотризирано възпроизвеждане или промяна, дори и отчасти на документа.

BS • Sadržaj i slike iz ovog korisničkog priručnika napravljeni su isključivo za ST. S.p.A. i zaštićeni su autorskim pravima – zabranjena je svaka neovlaštena reprodukcija ili izmjena dokumenta, djelomično ili u potpunosti.

CS • Obsah a obrázky v tomto návodu k použití byly zpracovány jménem společnosti ST. S.p.A. a jsou chráněny autorským právem – Reprodukce či nepovolené pozměňování tohoto dokumentu, a to i částečné, je zakázáno.

DA • Indhold og illustrationer i denne vejledning er blevet skabt på vegne af ST. S.p.A. og er beskyttet af ophavsret – Enhver gengivelse eller ændring, også delvis, af dokumentet uden autorisation hertil er forbudt.

DE • Inhalt und Bilder dieser Bedienungsanleitung wurden im Namen von ST. S.p.A. erstellt und sind urheberrechtlich geschützt – Jede nicht genehmigte Vervielfältigung oder Veränderung, auch auszugsweise, dieses Dokuments ist verboten.

EL • Το περιεχόμενο και οι εικόνες στο παρόν εγχειρίδιο χρήσης δημιουργήθηκαν για λογαριασμό της εταιρείας ST. S.p.A. και προστατεύονται από πνευματικά δικαιώματα – Απαγορεύεται οποιαδήποτε αναπαραγωγή ή τροποποίηση, έστω και μερική, του εγχειρίδιου χωρίς έγκριση.

EN • The content and images in this User Manual were produced expressly for ST. S.p.A. and are protected by copyright – any unauthorised reproduction or modification to the document, either partially or in full, is prohibited.

ES • El contenido y las imágenes del presente manual de uso han sido creados por ST. S.p.A. y están protegidos por los derechos de autor – Se prohíbe toda reproducción o modificación, incluso parcial, no autorizada del documento.

ET • Käesoleva kasutusjuhendi sisu ja kujutised on toodetud konkreetselt ettevõttele ST. S.p.A. ja neile rakendub autoriõiguseseadus – dokumendi igasugune osaline või täielik ilma loata reprodutseerimine või muutmine on keelatud.

FI • Tämän käyttöoppaan sisältö ja kuvat on valmistettu ST. S.p.A. -yhtiön toimesta ja niitä suojava tekijänoikeuslaki. – Asiakirjan kaikenlainen kopioiminen tai muuttaminen, osittainkin, on kielletty ilman erityistä lupaa.

FR • Le contenu et les images du présent manuel d'utilisation ont été réalisés pour le compte de ST. S.p.A. et sont protégés par un droit d'auteur – Toute reproduction ou modification non autorisée, même partielle, du document, est interdite.

HR • Sadržaj i slike u ovom priručniku za uporabu izrađeni su za tvrtku ST. S.p.A. te su obuhvaćeni autorskim pravima – Zabranjuje se neovlašteno umnožavanje ili prilagodba, djelomična ili u cijelosti, ovog dokumenta.

HU • Ennek a használati útmutatónak a tartalma és a benne szereplő képek kizárólag a ST. S.p.A. számára készültek és szerzői joggal védettek – tilos a dokumentum bármely részének vagy egészének engedély nélküli sokszorosítása és módosítása.

LT • Šio naudotojų vadovo turinys ir paveikslėliai skirti tik „ST. S.p.A.“ ir yra saugomi autorių teisėmis – dokumentą atgaminti ar modifikuoti, visiškai arba iš dalies, yra draudžiami.

LV • Šis lietotāja rokasgrāmatas saturs un attēli ir veidoti tikai ST. S.p.A. un ir aizsargāti ar autortiesībām. Jebkāda dokumenta vai tā daļas prettiesiska kopēšana vai pārveide ir stingri aizliegta.

MK • Содржината и сликите во Упатството за корисникот се подготвени исклучиво за ST. S.p.A. и се заштитени со авторски права – забрането е секое делумно или целосно неовластено репродуцирање или измена на документот.

NL • De inhoud en de afbeeldingen van deze gebruikshandleiding werden gerealiseerd voor rekening van ST. S.p.A. en zijn beschermd door het auteursrecht – Elke niet-geautoriseerde reproductie of wijziging, ook gedeeltelijke, van het document is verboden.

NO • Innholdet og bildene i denne brukerveiledningen er utført på oppdrag fra ST. S.p.A. og er beskyttet ved opphavsrett – Enhver gjengivelse eller endring, selv kun delvis, er forbudt.

PL • Treść oraz ilustracje zawarte w niniejszej instrukcji obsługi powstały na zlecenie spółki ST. S.p.A. i są chronione prawami autorskimi – Zabrania się wszelkiego kopiowania bądź modyfikowania, także częściowego, niniejszego dokumentu bez uzyskania stosownej zgody.

PT • As imagens e os conteúdos contidos no presente Manual do Utilizador foram expressamente criados para uso exclusivo da ST. S.p.A., encontrando-se protegidos por direitos de autor. Qualquer tipo de reprodução ou alteração, parcial ou integral, não autorizadas deste Manual estão expressamente proibidas.

RO • Conținutul și imaginile din manualul de utilizare de față au fost realizate în numele ST. S.p.A. și sunt protejate de drepturi de autor – Este interzisă orice reproducere sau modificare chiar și parțială neautorizată a documentului.

RU • Тесты и изображения, содержащиеся в настоящем руководстве, были созданы в интересах ST. S.p.A. и защищены авторскими правами – Любое несанкционированное воспроизведение или изменение документа запрещено.

SK • Obsah a obrázky v tomto návode na používanie boli spracované menom spoločnosti ST. S.p.A. a sú chránené autorským právom – Reprodukcie či nepovolené pozměňovanie tohto dokumentu, a to aj čiastočné, je zakázané.

SL • Vsebine in slike v tem uporabniškem priručniku so izdelane za podjetje ST. S.p.A. in so zaščitene z avtorskimi pravicami – vsakršno nepooblaščenno razmnoževanje ali spreminjanje dokumenta, v celoti ali delno, je prepovedano.

SR • Sadržaj i slike ovog priručnika za upotrebu su napravljeni u ime ST. S.p.A. i zaštićeni su autorskim pravima – Zabranjena je svaka potpuna ili delimična reprodukcija ili izmena dokumenta bez odobrenja.

SV • Innehållet och bilderna i denna användarhandbok har framställts för ST. S.p.A. och skyddas av upphovsrätt – all form av reproduktion eller ändring, även partiell, som inte auktoriserats är förbjuden.

TR • Bu Kullanıcı Kilavuzundaki içerik ve resimler açığıca ST. S.p.A. için üretilmiştir ve telif hakkı ile korunmaktadır – dokümanın izinsiz olarak tamamen ya da kısmen herhangi bir şekilde çoğaltılması ya da dağıtılması yasaktır.



REPRIS ET ÉCOLOGIQUE	 LWA dB
Type:	
Art.N-s/n	



FR

Cet appareil,
ses accessoires,
piles et cordons
se recyclent

REPRISE
À LA LIVRAISON



OU

À DÉPOSER
EN MAGASIN



OU

À DÉPOSER
EN DÉCHÈTERIE



Points de collecte sur www.quefairedemesdechets.fr
Privilégiez la réparation ou le don de votre appareil !



FR



ST. S.p.A.
Via del Lavoro, 6
31033 Castelfranco Veneto (TV)
ITALY

STIGA LTD (UK Importer)
6 Stansted Courtyard, Parsonage Road,
Takeley, Bishop's Stortford, Essex, England,
CM22 6PU, United Kingdom