

- IT** **Potatrice ad Asta alimentata a batteria**  
MANUALE DI ISTRUZIONI  
ATTENZIONE: prima di usare la macchina, leggere attentamente il presente libretto.
- BG** **Акумулаторна ножица с прът**  
УПЪТВАНЕ ЗА УПОТРЕБА  
ВНИМАНИЕ: преди да използвате машината прочетете внимателно настоящата книжка.
- BS** **Akumulatorska teleskopska pila**  
UPUTSTVO ZA UPOTREBU  
PAŽNJA: prije nego što koristite ovu mašinu, pažljivo pročitajte priručnik s uputama.
- CS** **Akumulátorová tyčová vyvѣtňovací pila**  
NÁVOD K POUŽITÍ  
UPOZORNĚNÍ: před použitím stroje si pozorně přečtěte tento návod k použití.
- DA** **Bæskæringsmaskine med batteriforsynet stang**  
BRUGSANVISNING  
ADVARSEL: læs instruktionsbogen omhyggeligt igennem, før du tager denne maskine i brug.
- DE** **Batteriebetriebener Hoch-Entaster**  
GEBRAUCHSANWEISUNG  
ACHTUNG: Vor Inbetriebnahme des Geräts die Gebrauchsanleitung aufmerksam lesen.
- EL** **Κλαδευτήρι μπαταρίας τηλεσκοπικό**  
ΟΔΗΓΙΕΣ ΧΡΗΣΗΣ  
ΠΡΟΣΟΧΗ: πριν χρησιμοποιήσετε το μηχάνημα, διαβάστε προσεκτικά το παρον εγχειρίδιο.
- EN** **Battery powered pole-mounted pruner**  
OPERATOR'S MANUAL  
WARNING: read thoroughly the instruction booklet before using the machine.
- ES** **Podadora alimentada por batería**  
MANUAL DE INSTRUCCIONES  
ATENCIÓN: antes de utilizar la máquina, leer atentamente el presente manual.
- ET** **Akutoitega varrega oksakäärid**  
KASUTUSJUHEND  
TÄHELEPANU: enne masina kasutamist lugeda tähelepanelikult antud kasutusjuhendit.
- FI** **Akkukäyttöinen pystykarsintasaha**  
KÄYTTÖOHJEET  
VAROITUS: lue käyttöopas huolellisesti ennen koneen käyttöä
- FR** **Perche élagueuse à batterie**  
MANUEL D'UTILISATION  
ATTENTION: lire attentivement le manuel avant d'utiliser cette machine.
- HR** **Obrezač za rad na visini, s baterijskim napajanjem**  
PRIRUČNIK ZA UPORABU  
POZOR: prije uporabe stroja, pažljivo pročitajte ovaj priručnik.
- HU** **Rúdra szerelt akkumulátoros gallyazók**  
HASZNÁLATI UTASÍTÁS  
FIGYELEM! a gép használatá előtt olvassa el figyelmesen a jelen kézikönyvet.
- LT** **Akumulatorinė teleskopinė aukštapijovė**  
NAUDOJIMO INSTRUKCIJOS  
DĖMESIO: prieš naudojant enginį, atidžiai perskaityti šį naudotojo vadovą.
- LV** **Masta zargriezis ar barošānu no akumulatora**  
LIETOŠANAS INSTRUKCIJA  
UZMANĪBU: pirms aparāta lietošanai rūpīgi izlasiet doto instrukciju.
- MK** **Режач на шипка со напојување на батерија**  
УПАТСТВА ЗА УПОТРЕБА  
ВНИМАНИЕ: прочитајте го внимателно ова упатство пред да ја користите машината.
- NL** **Batteridrevet sag med forlengelse**  
GEBRUIKERSHANDLEIDING  
LET OP: vooraleer de machine te gebruiken, dient men deze handleiding aandachtig te lezen.
- NO** **Beskæringsmaskin og hekksakser multiverktøy batteridrevet**  
INSTRUKSJONSBOK  
ADVARSEL: les denne bruksanvisningen nøye før du bruker maskinen.

**PL** Okrzesywarka akumulatorowa z wysięgnikiem  
INSTRUKCJE OBSŁUGI

OSTRZEŻENIE: przed użyciem maszyny, należy uważnie przeczytać niniejszą instrukcję.

**PT** Podadora com Haste alimentada a bateria  
MANUAL DE INSTRUÇÕES

ATENÇÃO: antes de usar a máquina, leia atentamente o presente manual.

**RO** Motoferăstrău cu tijă pentru elagaj alimentat cu baterie  
MANUAL DE INSTRUCȚIUNI

ATENȚIE: înainte de a utiliza mașina, citiți cu atenție manualul de față.

**RU** Секатор на штанге с батарейным питанием  
РУКОВОДСТВО ПО ЭКСПЛУАТАЦИИ

ВНИМАНИЕ: прежде чем пользоваться оборудованием, внимательно прочтите это руководство по эксплуатации.

**SK** Akumulátorová tyčová vyvetvovacia píla  
NÁVOD NA POUŽITIE

UPOZORNENIE: pred použitím stroja si pozorne prečítajte tento návod.

**SL** Akumulatorska žaga za obvejevanje z drogom  
PRIROČNIK ZA UPORABO

POZOR: preden uporabite stroj, pazljivo preberite priloženi priročnik z navodili.

**SR** Akumulatorska teleskopska testera  
PRIRUČNIK SA UPUTSTVIMA

PAŽNJA: pre korišćenja mašine pažljivo pročitati ovaj priručnik.

**SV** Batteridrivna Häcksaxar  
BRUKSANVISNING

VARNING: läs igenom hela detta häfte innan du använder maskinen.

**TR** Batarya beslemeli Çubuklu Budama Makinesi  
KULLANIM KILAVUZU

DİKKAT: makineyi kullanmadan önce talimatlar içeren kilavuzu dikkatle okuyun.

ITALIANO - Istruzioni Originali .....	<b>IT</b>
БЪЛГАРСКИ - Инструкция за експлоатация .....	<b>BG</b>
BOSANSKI - Prijevod originalnih uputa .....	<b>BS</b>
ČESKY - Překlad původního návodu k používání .....	<b>CS</b>
DANSK - Oversættelse af den originale brugsanvisning .....	<b>DA</b>
DEUTSCH - Übersetzung der Originalbetriebsanleitung .....	<b>DE</b>
ΕΛΛΗΝΙΚΑ - Μετάφραση των πρωτοτύπων οδηγιών .....	<b>EL</b>
ENGLISH - Translation of the original instruction .....	<b>EN</b>
ESPAÑOL - Traducción del Manual Original .....	<b>ES</b>
EESTI - Algupärase kasutusjuhendi tõlge .....	<b>ET</b>
SUOMI - Alkuperäisten ohjeiden käännös .....	<b>FI</b>
FRANÇAIS - Traduction de la notice originale .....	<b>FR</b>
HRVATSKI - Prijevod originalnih uputa .....	<b>HR</b>
MAGYAR - Eredeti használati utasítás fordítása .....	<b>HU</b>
LIETUVIŠKAI - Originalių instrukcijų vertimas .....	<b>LT</b>
LATVIEŠU - Instrukciju tulkojums no oriģināl valodas .....	<b>LV</b>
МАКЕДОНСКИ - Превод на оригиналните упатства .....	<b>MK</b>
NEDERLANDS - Vertaling van de oorspronkelijke gebruiksaanwijzing .....	<b>NL</b>
NORSK - Oversettelse av den originale bruksanvisningen .....	<b>NO</b>
POLSKI - Tłumaczenie instrukcji oryginalnej .....	<b>PL</b>
PORTUGUÊS - Tradução do manual original .....	<b>PT</b>
ROMÂN - Traducerea manualului fabricantului .....	<b>RO</b>
РУССКИЙ - Перевод оригинальных инструкций .....	<b>RU</b>
SLOVENSKY - Preklad pôvodného návodu na použitie .....	<b>SK</b>
SLOVENŠČINA - Prevod izvornih navodil .....	<b>SL</b>
SRPSKI - Prevod originalnih uputstva .....	<b>SR</b>
SVENSKA - Översättning av bruksanvisning i original .....	<b>SV</b>
TÜRKÇE - Orijinal Talimatların Tercümesi .....	<b>TR</b>

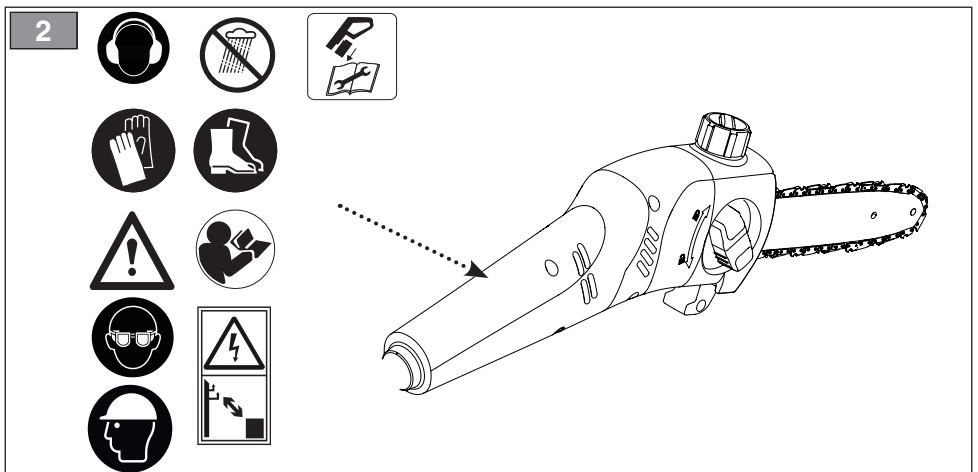
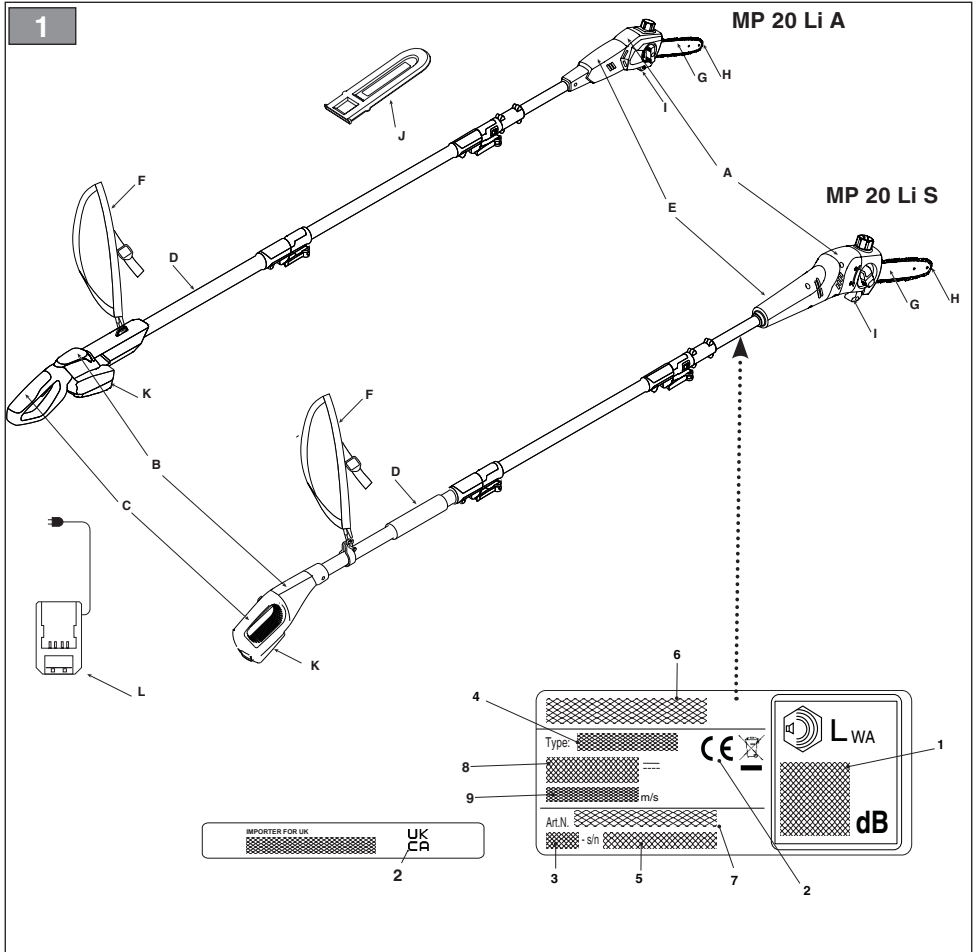

3

MP 20 Li A

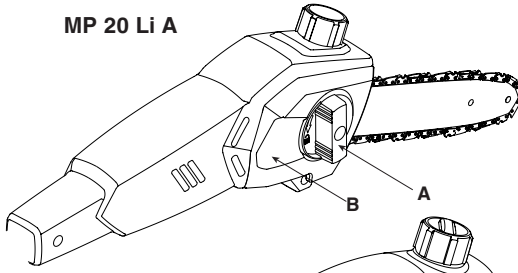

MP 20 Li S

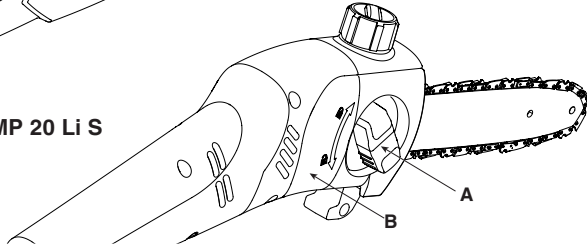

4

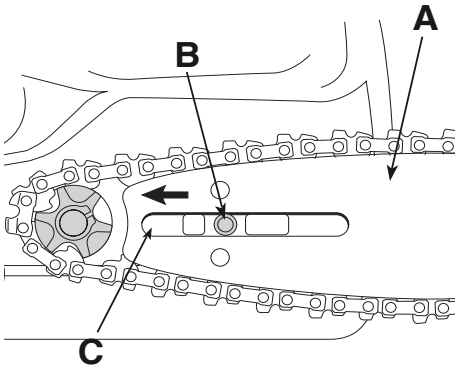

5

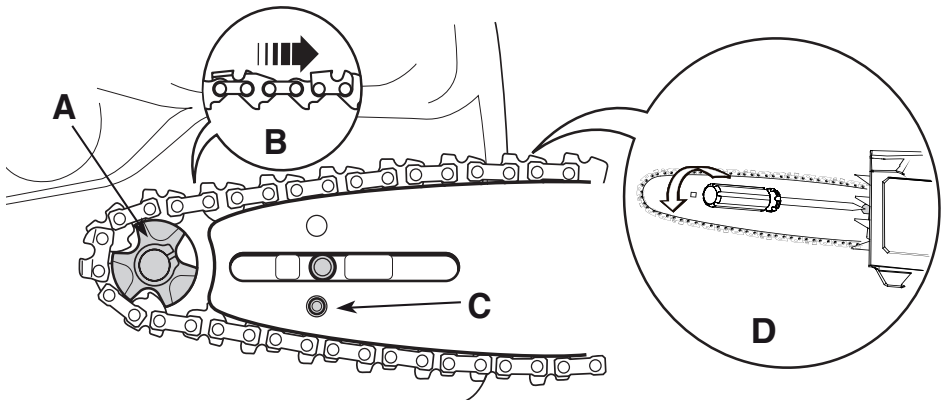

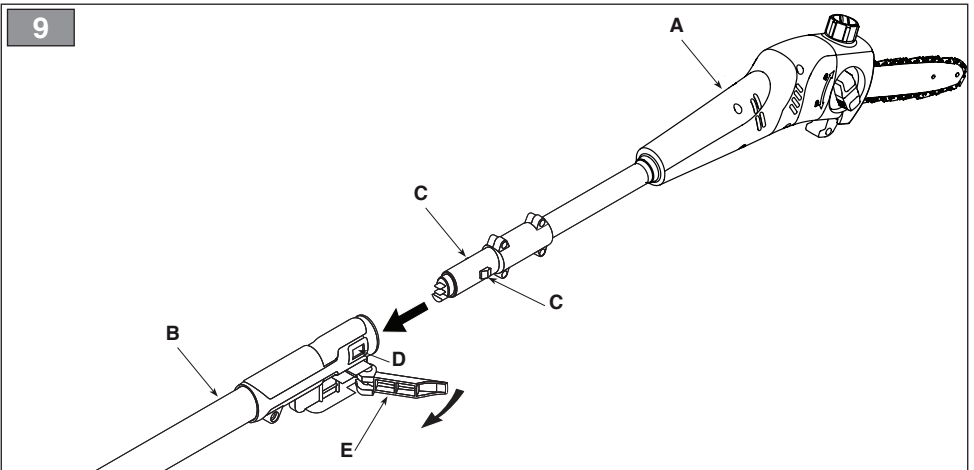
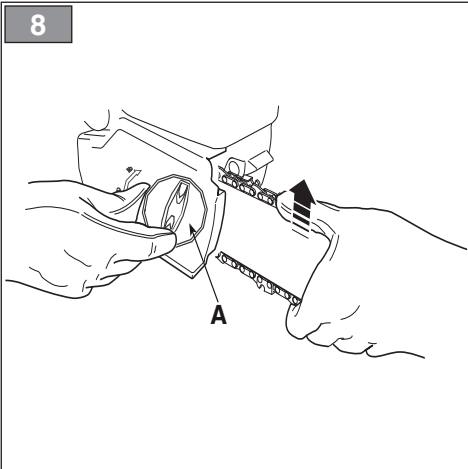
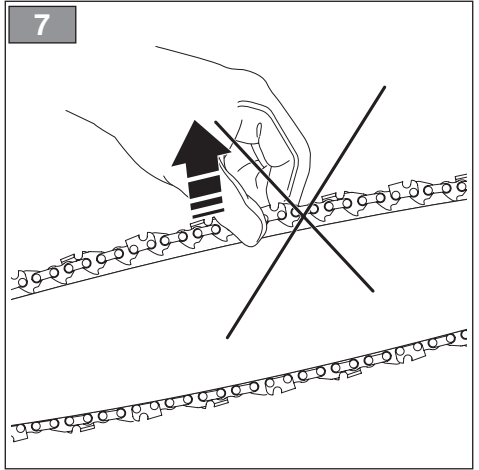
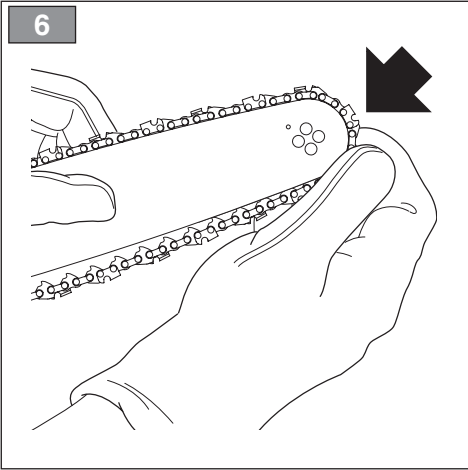

10

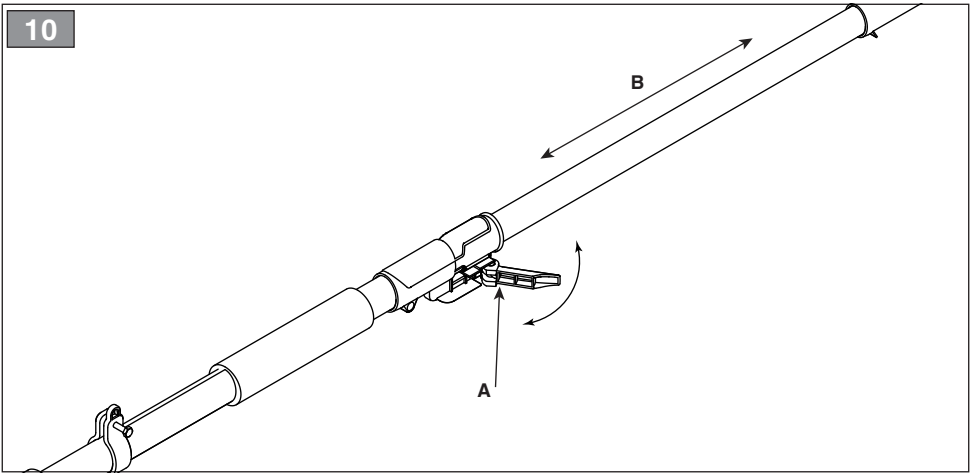

11

MP 20 Li A

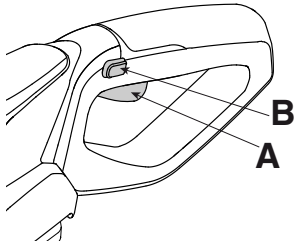

MP 20 Li S

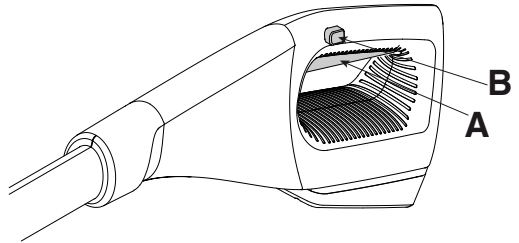

12

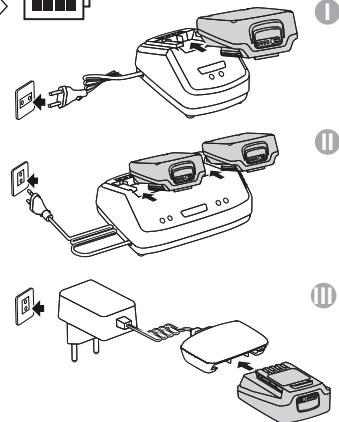

13

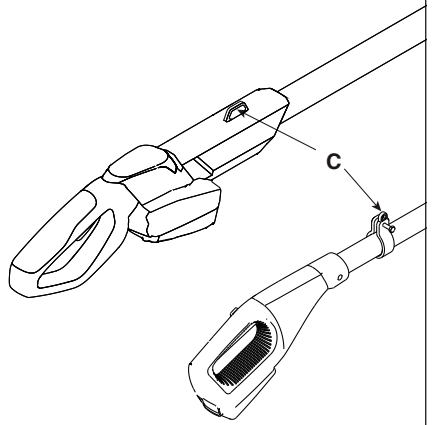
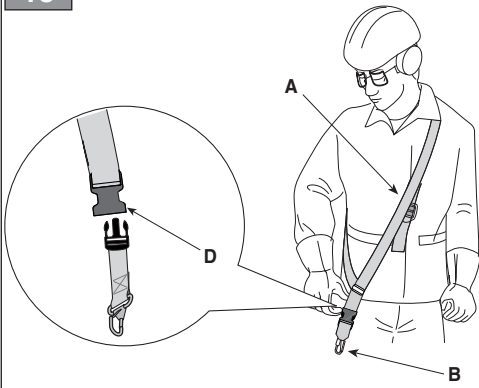

14

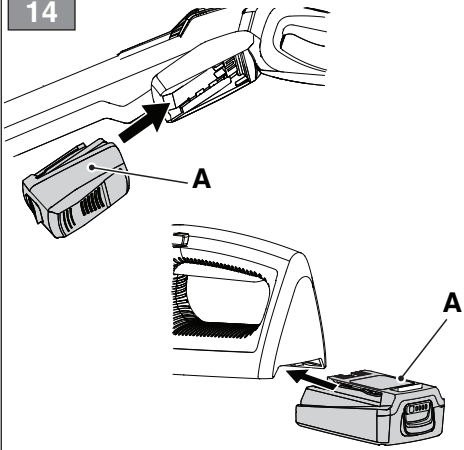

15

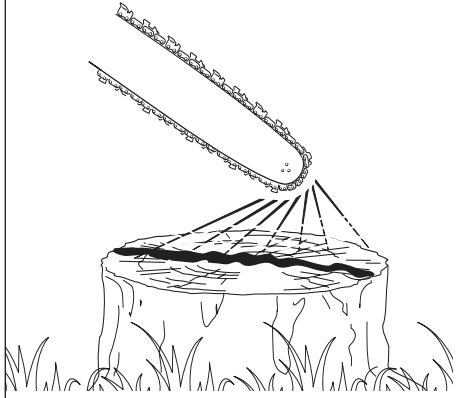

16

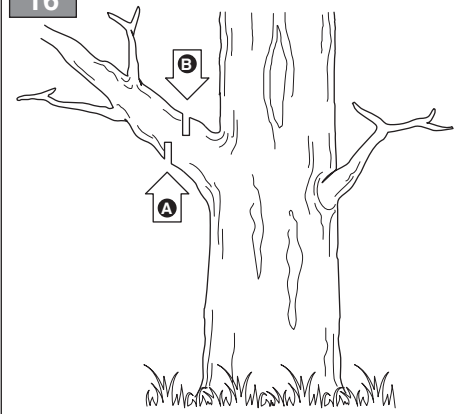

17

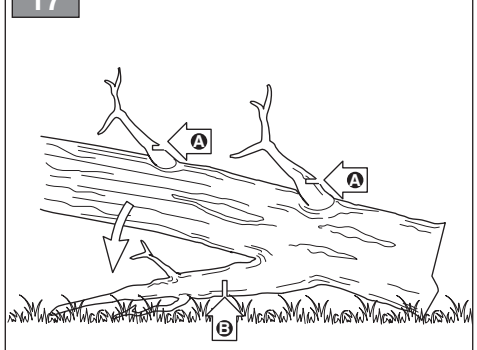



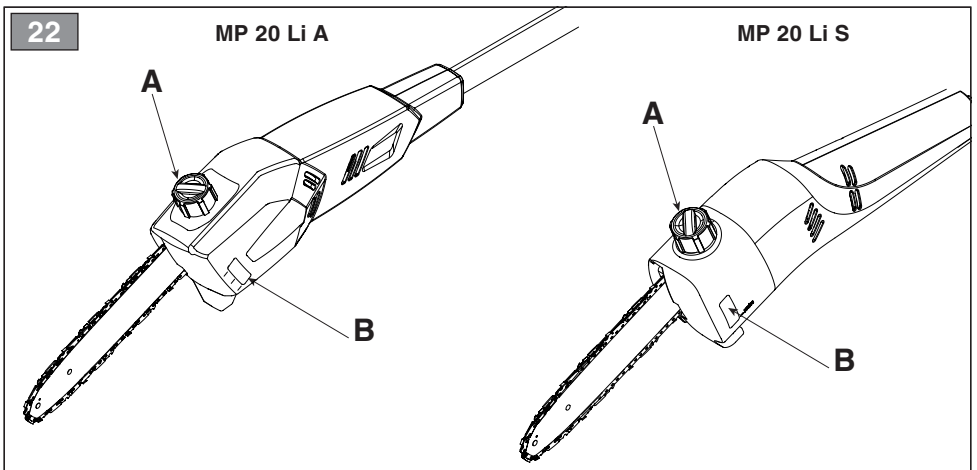
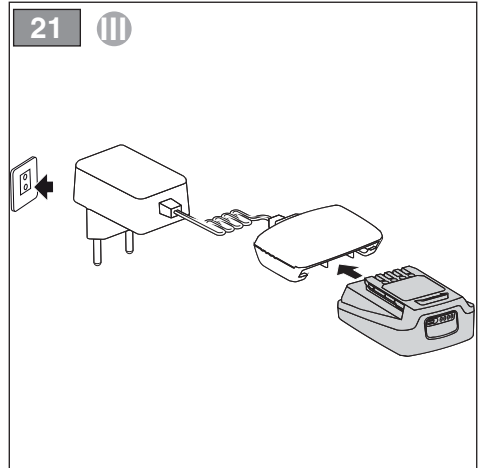
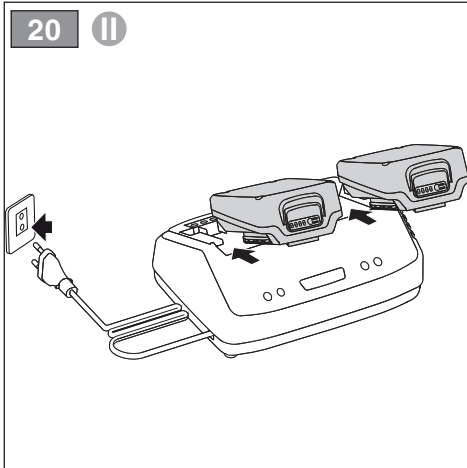
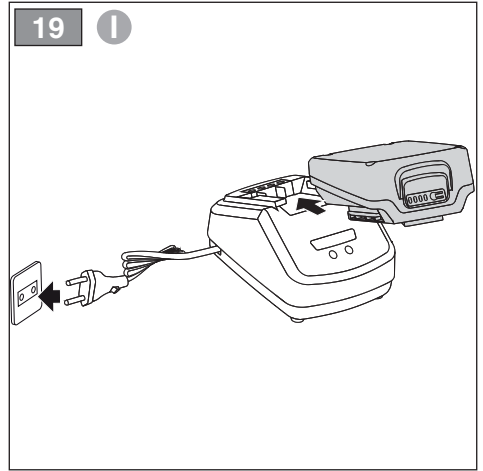
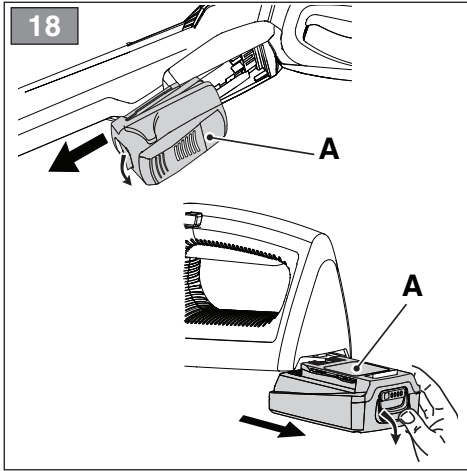

23

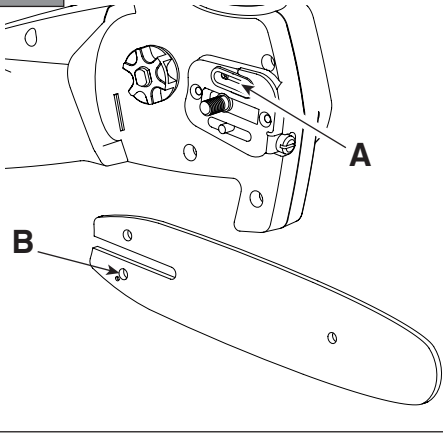

24

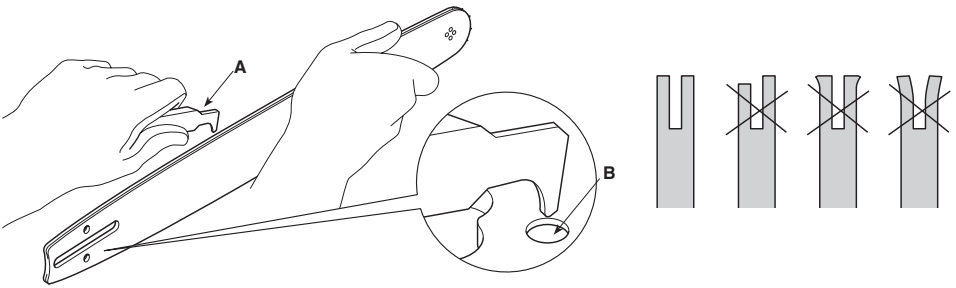

25

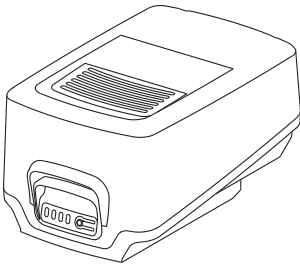

26

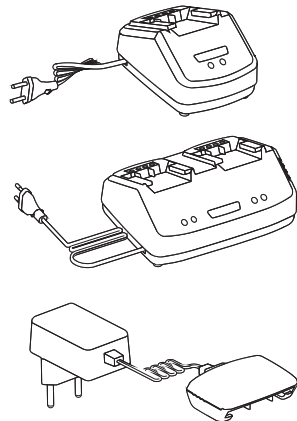

[1]	DATI TECNICI		MP 20 Li A	MP 20 Li S
[2]	Tensione e frequenza di alimentazione MAX	V / d.c.	20	20
[3]	Tensione e frequenza di alimentazione NOMINAL	V / d.c.	18	18
[4]	Velocità massima della catena	m/s	5	5
[5]	Frequenza massima di rotazione del mandrino	min <sup>-1</sup>	2500	2500
[6]	Lunghezza di taglio	cm	20	20
[7]	Spessore catena	mm	1,3	1,3
[8]	Denti / passo del pignone catena		33 / 3/8"	33 / 3/8"
[9]	Capacità del serbatoio dell'olio	ml	115	115
[10]	Peso senza dispositivo di taglio e imbracatura	kg	3,3	3,2
[11]	Livello di pressione acustica misurato	dB(A)	73,4	73,4
[12]	Incertezza di misura	dB(A)	3	3
[13]	Livello di potenza acustica misurato	dB(A)	85,4	85,4
[12]	Incertezza di misura	dB(A)	1,02	1,02
[14]	Livello di potenza acustica garantito	dB(A)	87	87
[15]	Livello di vibrazioni			
[16]	- Impugnatura anteriore	m/s <sup>2</sup>	1,10	1,10
[17]	- Impugnatura posteriore	m/s <sup>2</sup>	1,14	1,14
[12]	Incertezza di misura	m/s <sup>2</sup>	1,5	1,5

[18]	ACCESSORI A RICHIESTA	
[19]	Gruppo batteria, mod.	BT 20 Li 2.0 S BT 20 Li 4.0 S
[20]	Carica batteria	CG 20 Li CGD 20 Li CGW 20 Li

a) *NOTA: il valore totale dichiarato delle vibrazioni è stato misurato attenendosi ad un metodo normalizzato di prova e può essere utilizzato per fare un paragone tra un utensile e l'altro. Il valore totale delle vibrazioni può essere utilizzato anche in una valutazione preliminare dell'esposizione.*

b) *AVVERTENZA: l'emissione di vibrazioni nell'uso effettivo dell'utensile può essere diversa dal valore totale dichiarato a seconda dei modi in cui si utilizza l'utensile. Pertanto è necessario, durante il lavoro, adottare le seguenti misure di sicurezza volte a proteggere l'operatore: indossare guanti durante l'uso, limitare i tempi d'utilizzo della macchina e accorciare i tempi in cui si tene premuta la leva comando acceleratore.*

[21] TABELLA PER LA CORRETTA COMBINAZIONE DI BARRA E CATENA (Cap. 13.3)				
[22] PASSO	[23] BARRA			[24] CATENA
[25] Pollici	[26] Lunghezza: Pollici / cm	[27] Larghezza scanalatura: Pollici / mm	[28] Codice	[28] Codice
3/8" / 9,525 mm	8" / 20,32	0.50" / 1.3mm	080SDEA	91P033X

<p>[1] <b>BG - ТЕХНИЧЕСКИ ДАННИ</b></p> <p>[2] МАХ напрежение и честота на захранване</p> <p>[3] НОМИНАЛНО напрежение и честота на захранване</p> <p>[4] Максимална скорост на веригата</p> <p>[5] Максимална честота на въртене на шпиндела</p> <p>[6] Дължина на срязване</p> <p>[7] Дебелина на веригата</p> <p>[8] Събци / съгълка на пиърона на верига</p> <p>[9] Вместимост на резервоара на маслото</p> <p>[10] Тегло (без акумулатор, без шина и верига)</p> <p>[11] Измерено ниво на акустична мощност</p> <p>[12] Измервателна грешка</p> <p>[13] Ниво на измерена акустична мощност</p> <p>[14] Гарантирано ниво на звукова мощност</p> <p>[15] Ниво на вибрации</p> <p>[16] - Предна ръкохватка</p> <p>[17] - Задна ръкохватка</p> <p>[18] ПРИНАДЛЕЖНОСТИ ПО ЗАЯВНА</p> <p>[19] Блок на акумулатора, мод.</p> <p>[20] Заредане на акумулатора</p> <p>[21] ТАБЛИЦА ЗА ПРАВИЛНА КОМБИНАЦИЯ НА ШИНА И ВЕРИГА (Гл. 15.3)</p> <p>[22] СЪГЪЛКА</p> <p>[23] ШИНА</p> <p>[24] ВЕРИГА</p> <p>[25] Палци / mm</p> <p>[26] Дължина: Палци / cm</p> <p>[27] Ширина на жлеба: Палци / mm</p> <p>[28] Код</p> <p>a) ЗАБЕЛЕЖЕНА: декларираната обща стойност на вибрации е измерена придръжвайки се към стандартизиран метод на изпитване и може да се използва за сравнение на сравнение между един и друг инструмент. Общата стойност на вибрации може да се използва и за предварителна оценка на излагането.</p> <p>b) ПРЕДУПРЕЖДЕНИЕ: издаването на вибрации при реалното използване на инструмента може да бъде различна от общата декларирана стойност, в зависимост от начините на използване на инструмента. Поради това е необходимо по време на работа да се вземат следните предпазни мерки целящи предпазването на оператора: носете ръкавици по време на използването, ограничете времето на използване на машината и намалете времето, през които се държи натиснат лоста за управление на ускорителя.</p>	<p>[1] <b>BS - TEHNIČKI PODACI</b></p> <p>[2] MAKS. napon i frekvencija napajanja</p> <p>[3] NAZIVNI napon i frekvencija napajanja</p> <p>[4] Maksimalna brzina lanca</p> <p>[5] Maksimalna frekvencija okretanja vretena</p> <p>[6] Dužina reza</p> <p>[7] Debljina lanca</p> <p>[8] Zupci / korak gonjenog zupčanika lanca</p> <p>[9] Kapacitet spremnika za ulje</p> <p>[10] Težina (bez baterije, bez vodilice lanca i lanca)</p> <p>[11] Izmjereni nivo zvučnog pritiska</p> <p>[12] Mjerna nesigurnost</p> <p>[13] Izmjereni nivo zvučne snage</p> <p>[14] Zajamčeni nivo zvučne snage</p> <p>[15] Nivo vibracija</p> <p>[16] - Prednji rukohvat</p> <p>[17] - Zadnji rukohvat</p> <p>[18] DODATNA OPREMA NA ZAHTJEV</p> <p>[19] Baterija, mod.</p> <p>[20] Punjač baterije</p> <p>[21] TABELA ZA ISPRAVNU KOMBINACIJU VODILICE LANCA I LANCA (Pogl. 15.3)</p> <p>[22] KORAK</p> <p>[23] VODILICA LANCA</p> <p>[24] LANAC</p> <p>[25] Inč / mm</p> <p>[26] Dužina: Inč / mm</p> <p>[27] Širina žljeba: Inč / mm</p> <p>[28] Sifra</p> <p>a) NAPOMENA: ukupna prijavljena vrijednost vibracija izmjerena je prema normalizovanoj metodi ispitivanja i može se koristiti za vršenje poređenja između dvije alatke. Ukupna vrijednost vibracija može se koristiti i prilikom prethodne procjene izloženosti.</p> <p>b) UPOZORENJE: emisija vibracija prilikom stvarne upotrebe alatke može se razlikovati od ukupne prijavljene vrijednosti u zavisnosti od načina na koji se koristi alatka. Stoga je neophodno, za vrijeme rada, primijeniti sljedeće sigurnosne mjere za zaštitu radnika: koristiti rukavice za vrijeme upotrebe, ograničiti vrijeme upotrebe mašine i skratiti vrijeme za koje se drži pritisnuta poluga komande gasa.</p>	<p>[1] <b>CS - TECHNICKÉ PARAMETRY</b></p> <p>[2] MAX. napájecí napětí a frekvence</p> <p>[3] JMENOVITÉ napájecí napětí a frekvence</p> <p>[4] Maximální rychlost řetězu</p> <p>[5] Maximální frekvence otáčení vřetena</p> <p>[6] Řezná délka</p> <p>[7] Tloušťka řetězu</p> <p>[8] Zuby / rozteč řetězky</p> <p>[9] Kapacita olejové nádrže</p> <p>[10] Hmotnost (bez akumulátoru, bez vodící lišty a řetězu)</p> <p>[11] Naměřená úroveň akustického tlaku</p> <p>[12] Nepřesnost měření</p> <p>[13] Naměřená úroveň akustického výkonu</p> <p>[14] Zaručená úroveň akustického výkonu</p> <p>[15] Úroveň vibrací</p> <p>[16] - Přední rukojeť</p> <p>[17] - Zadní rukojeť</p> <p>[18] VOLÍTELENE PRÍSLUŠENSTVÍ</p> <p>[19] Akumulátorová jednotka, mod.</p> <p>[20] Nabíječka akumulátoru</p> <p>[21] TABUĽKA PRO SPRÁVNOU KOMBINACI VODIČI LISTY A RETEZU (kap. 15.3)</p> <p>[22] ROZTEČ</p> <p>[23] VODIČI LISTA</p> <p>[24] RETEZ</p> <p>[25] Palce / mm</p> <p>[26] Délka: Palce / cm</p> <p>[27] Šířka drážky: Palce / mm</p> <p>[28] Kód</p> <p>a) POZNÁMKA: prohlášená celková hodnota vibrací byla naměřena s použitím normalizované zkušební metody a lze ji použít pro srovnání jednotlivých nástrojů. Celková hodnota vibrací může být použita také při přípravěm vyhodnocování vystavení vibračním.</p> <p>b) VAROVÁNÍ: emise vibrací při skutečném použití nástroje může být odlišná od deklarované celkové hodnoty v závislosti na režimech, ve kterých se daný nástroj používá. Proto je třeba během práce přijmout níže uvedené bezpečnostní opatření, jejichž cílem je ochránit operátora: během běžného použití mějte nasazené rukavice a omezte dobu použití stroje a zkratěte dobu, během kterých je zatlačena ovládací páka plynu.</p>
--	---	---

<p>[1] <b>DA - TEKNISKE DATA</b></p> <p>[2] MAKS. forsyningspænding og -frekvens</p> <p>[3] NOMINEL forsyningspænding og -frekvens</p> <p>[4] Maksimal kædehastighed</p> <p>[5] Maksimal omdrejningsfrekvens for spindel</p> <p>[6] Klippelængde</p> <p>[7] Kædens tykkelse</p> <p>[8] Antal tænder/deiling på kædehjul</p> <p>[9] Oiletankens-kapacitet</p> <p>[10] Vægt (uden batteri, uden sværd og kæde)</p> <p>[11] Målt lydtryksniveau</p> <p>[12] Usikkerhed ved målingen</p> <p>[13] Målt lydeffektniveau</p> <p>[14] Garanteret lydeffektniveau</p> <p>[15] Vibrationsniveau</p> <p>[16] - Forreste håndtag</p> <p>[17] - Bagerste håndtag</p> <p>[18] TILBÆHØR</p> <p>[19] Batterienhed, mod.</p> <p>[20] Batterioplader</p> <p>[21] TABEL TIL DEN KORREKTE KOMBINATION AF SVÆRD OG KÆDE (Kap. 15.3)</p> <p>[22] AKSELAFSTAND</p> <p>[23] SVÆRD</p> <p>[24] KÆDE</p> <p>[25] Tommer / mm</p> <p>[26] Længde: Tommer / cm</p> <p>[27] Sporbrede: Tommer / mm</p> <p>[28] Kode</p> <p>a) BEMÆRK: den samlede erklærede værdi af vibrationer blev målt ifølge en standardiseret metode til afprøvning og kan bruges til at foretage en sammenligning mellem forskellige redskaber. Den samlede værdi af vibrationer kan også bruges til en indledende vurdering af eksponeringen.</p> <p>b) ADVARSEL: den faktiske udsendelse af vibrationer i forbindelse med brug af redskabet kan afvige fra den samlede atterestede værdi afhængigt af den konkrete brug af redskabet. Derfor er det nødvendigt, at man under arbejdet tager følgende sikkerhedsforanstaltninger for at beskytte brugeren. Bær handsker under brug, begræns den tid maskinen bruges og forkort den tid hvor gashåndtaget holdes indtrykket.</p>	<p>[1] <b>DE - TECHNISCHE DATEN</b></p> <p>[2] Netzspannung und -frequenz / Stromaufnahme MAX</p> <p>[3] Netzspannung und -frequenz / Stromaufnahme NOMINAL</p> <p>[4] Maximale Geschwindigkeit der Kette</p> <p>[5] Max Spindelrehzahl</p> <p>[6] Schnittlänge</p> <p>[7] Dicke der Kette</p> <p>[8] Zähne / Teilung des Kettenrads</p> <p>[9] Fassungsvermögen Öltank</p> <p>[10] Gewicht (ohne Batterie, Schwert und Kette)</p> <p>[11] Gemessener Schalldruckpegel</p> <p>[12] Messunsicherheit</p> <p>[13] Gemessener Schalleistungspegel</p> <p>[14] Garantiertes Schalleistungspegel</p> <p>[15] Vibrationspegel</p> <p>[16] - Vorderer Handgriff</p> <p>[17] - Hinterer Handgriff</p> <p>[18] SONDERZUBEHÖR</p> <p>[19] Batterieeinheit, Mod.</p> <p>[20] Batterieabladegerät</p> <p>[21] TABELLE FÜR DIE KORREKTE KOMBINATION VON SCHWERT UND KETTE (Kap. 15.3)</p> <p>[22] GLIEDLÄNGE</p> <p>[23] SCHWERT</p> <p>[24] KETTE</p> <p>[25] Zoll</p> <p>[26] Länge: Zoll / cm</p> <p>[27] Nutbreite: Zoll / mm</p> <p>[28] Code</p> <p>a) HINWEIS: Der erklärte Gesamtwert der Vibrationen wurde durch eine standardisierte Methode gemessen. Er kann verwendet werden, um einen Vergleich zwischen verschiedenen Werkzeugen anzustellen. Der Gesamtwert der Vibrationen kann auch bei einer Vorabewertung der Vibrationsbelastung eingesetzt werden.</p> <p>b) WARNUNG: Die Schwingungsemission bei der effektiven Verwendung des Werkzeugs kann sich je nach den Einsatzarten des Werkzeugs vom erklärten Gesamtwert unterscheiden. Deshalb ist es notwendig, während der Arbeit die folgenden Sicherheitsmaßnahmen zu ergreifen, um den Bediener zu schützen: Handschuhe während der Verwendung anziehen, die Einsatzzeiten der Maschine begrenzen und die Zeiten verkürzen, in denen man den Gashebel gedrückt hält.</p>	<p>[1] <b>EL - ΤΕΧΝΙΚΑ ΧΑΡΑΚΤΗΡΙΣΤΙΚΑ</b></p> <p>[2] Τάση και συχνότητα τροφοδοσίας ΜΕΓ.</p> <p>[3] Τάση και συχνότητα τροφοδοσίας ΟΝΟΜΑΣΤΙΚΗ</p> <p>[4] Μέγιστη ταχύτητα της αλυσίδας</p> <p>[5] Μέγιστη συχνότητα περιστροφής του τoοκ</p> <p>[6] Μήκος κοπής</p> <p>[7] Πάχος αλυσίδας</p> <p>[8] Δόντα / βήμα πινión αλυσίδας</p> <p>[9] Χωρητικότητα του δοχείου λαδιού</p> <p>[10] Βάρος (χωρίς μπαταρία, χωρίς μάτσο και αλυσίδα)</p> <p>[11] Μετρούμενη στάθμη ακουστικής πίεσης</p> <p>[12] Αβεβαιότητα μέτρησης</p> <p>[13] Μετρούμενη στάθμη ακουστικής ισχύος</p> <p>[14] Στάθμη εγγυώμενης ηχητικής ισχύος</p> <p>[15] Επίπεδο κραδασμών</p> <p>[16] - Εμπρός χειροαίτη</p> <p>[17] - Πίσω χειροαίτη</p> <p>[18] ΠΡΟΑΪΓΕΤΙΚΑ ΑΞΕΣΟΥΑΡ</p> <p>[19] Μπαταρία, μοντ.</p> <p>[20] Φορτιστής Μπαταρίας</p> <p>[21] ΠΙΝΑΚΑΣ ΓΙΑ ΤΟ ΣΩΣΤΟ ΣΥΝΔΥΑΣΜΟ ΤΗΣ ΠΙΝΑΚΑΣ ΚΑΙ ΤΗΣ ΑΛΥΣΙΔΑΣ (Κεφ. 15.3)</p> <p>[22] ΒΗΜΑ</p> <p>[23] ΛΑΜΑ</p> <p>[24] ΑΛΥΣΙΔΑ</p> <p>[25] Ίντσες / mm</p> <p>[26] Μήκος: Ίντσες / mm</p> <p>[27] Πλάτος αλυσάκας: Ίντσες / mm</p> <p>[28] Κωδικός</p> <p>a) ΣΗΜΕΙΩΣΗ: Η συνολική δηλωμένη τιμή των κραδασμών έχει μετρηθεί με βάση μια πρότυπη μέθοδο δοκιμής και μπορεί να χρησιμοποιηθεί για να γίνει ένα παράγων μεταξύ ενός εργαλείου και ενός άλλου. Η συνολική τιμή των κραδασμών μπορεί επίσης να χρησιμοποιηθεί για μια προκαταρκτική εκτίμηση της έκθεσης.</p> <p>b) ΠΡΟΕΙΔΟΠΟΙΗΣΗ: Η εκτίμηση κραδασμών κατά την πραγματική χρήση του εργαλείου μπορεί να είναι διαφορετική από τη συνολική δηλωμένη τιμή ανάλογα με τον τρόπο χρήσης του εργαλείου. Ωστόσο είναι αναγκαίο, κατά τη διάρκεια της εργασίας, να υποβιβαστείτε να ακολουθήα μέτρα ασφαλείας για να προσταφέιτε το χειρίστη: φορέστε γάντια κατά τη χρήση, περιορίστε το χρόνο χρήσης του μηχανήματος και μείωστε το χρόνο που κρατείται πατημένος ο μοχλός εντολής γκασιού.</p>
<p>[1] <b>EN - TECHNICAL DATA</b></p> <p>[2] Power supply frequency and voltage MAX</p> <p>[3] Power supply frequency and voltage NOMINAL</p> <p>[4] Maximum chain speed</p> <p>[5] Maximum rotational frequency of the spindle</p> <p>[6] Cutting length</p> <p>[7] Chain gauge</p> <p>[8] Chain pinion teeth / pitch</p> <p>[9] Oil tank capacity</p> <p>[10] Weight (without battery, bar and chain)</p> <p>[11] Measured sound pressure level</p> <p>[12] Uncertainty of measure</p> <p>[13] Guaranteed sound power level</p> <p>[14] Vibration level</p> <p>[15] Front handle</p> <p>[16] Rear handle</p> <p>[17] ACCESSORIES AVAILABLE ON REQUEST</p> <p>[18] Battery pack, model</p> <p>[19] Battery charger</p> <p>[20] CORRECT BAR AND CHAIN COMBINATION TABLE (Chap. 15.3)</p> <p>[22] PITCH</p> <p>[23] BAR</p> <p>[24] CHAIN</p> <p>[25] Inches</p> <p>[26] Length: Inches / cm</p> <p>[27] Groove width: Inches / mm</p> <p>[28] Code</p> <p>a) NOTE: the declared total vibration value was measured using a normalised test method and can be used to conduct comparisons between one tool and another. The total vibration value can also be used for a preliminary exposure evaluation.</p> <p>b) WARNING: the vibrations emitted during actual use of the tool can differ from the declared total value according to how the tool is used. Whilst working, therefore, it is necessary to adopt the following safety measures designed to protect the operator: wear protective gloves whilst working, use the machine for limited periods at a time and decrease the time during which the throttle trigger lever is pressed.</p>	<p>[1] <b>ES - DATOS TÉCNICOS</b></p> <p>[2] Tensión y frecuencia de alimentación MÁX</p> <p>[3] Tensión y frecuencia de alimentación NOMINAL</p> <p>[4] Velocidad máxima de la cadena</p> <p>[5] Frecuencia máxima de rotación del mandril</p> <p>[6] Longitud de corte</p> <p>[7] Cadená cadena</p> <p>[8] Dientes / paso del piñón cadena</p> <p>[9] Capacidad del depósito de aceite</p> <p>[10] Peso (sin batería, sin barra ni cadena)</p> <p>[11] Nivel de presión acústica medido</p> <p>[12] Incertidumbre de medida</p> <p>[13] Nivel de potencia acústica medido</p> <p>[14] Nivel de potencia acústica garantizado</p> <p>[15] Nivel de vibraciones</p> <p>[16] - Empuñadura anterior</p> <p>[17] - Empuñadura posterior</p> <p>[18] ACCESORIOS POR ENCARGO</p> <p>[19] Grupo de la batería, mod.</p> <p>[20] Cargador de la batería</p> <p>[21] TABLA PARA LA CORRECTA COMBINACIÓN DE BARRA Y CADENA (Cap. 15.3)</p> <p>[22] PASO</p> <p>[23] BARRA</p> <p>[24] CADENA</p> <p>[25] Pulgadas/mm</p> <p>[26] Longitud: Pulgadas/cm</p> <p>[27] Anchura ranura: Pulgadas/mm</p> <p>[28] Código</p> <p>a) NOTA: el valor total de la vibración se ha medido según un método normalizado de prueba y puede utilizarse para realizar una comparación entre una máquina y otra. El valor total de la vibración también se puede emplear para la valoración preliminar de la exposición.</p> <p>b) ADVERTENCIA: la emisión de vibración en el uso efectivo del aparato puede ser diferente al valor total declarado según los modos en los que se utiliza la herramienta. Por ello, durante la actividad se deben poner en práctica las siguientes medidas de seguridad para el usuario: usar guantes, limitar el tiempo de uso de la máquina, así como el tiempo que se mantiene presionado la palanca de mando del acelerador.</p>	<p>[1] <b>ET - TEHNILISED ANDMED</b></p> <p>[2] Pinge ja toitesagedus / MAKS.</p> <p>[3] Pinge ja toitesagedus / NOMINAALNE.</p> <p>[4] Keti maksimaalne kiirus</p> <p>[5] Võlli maksimaalne pöörlemissagedus</p> <p>[6] Lõikepikkus</p> <p>[7] Keti lõimõõt</p> <p>[8] Keti hammassratata hambad/samm</p> <p>[9] Õlipaagi maht</p> <p>[10] Kaal ilma aku, latti ja ketita</p> <p>[11] Mõõdetud helirõhutase</p> <p>[12] Mõõtemääramatus</p> <p>[13] Mõõdetud müra võimsuse tase</p> <p>[14] Garanteeritud müra võimsuse tase</p> <p>[15] Vibratsiooni tase</p> <p>[16] - Eesmine käepide</p> <p>[17] - Tagumine käepide</p> <p>[18] LISASEADMED TELLIMISEL</p> <p>[19] Aku, mud.</p> <p>[20] Akulaadaja</p> <p>[21] TABEL "SÄEKETTIDE JA -LATTIDE ÕIGE KOMBINATSIOON" (Ptk 15.3)</p> <p>[22] SAMM</p> <p>[23] LATT</p> <p>[24] KETT</p> <p>[25] Tollid / mm</p> <p>[26] Pikkus: Tollid / cm</p> <p>[27] Soone laius: Tollid / mm</p> <p>[28] Kood</p> <p>a) MÄRKUS: deklareeritud koguvibratsiooni tase mõõdeti standardiseeritud testi käigus, mille abil on võimalik võrrelda omavahel erinevate tööriistade vibratsiooni. Deklareeritud koguvibratsiooni võib kasutada ka eeldatava vibratsiooni käes olemise hindamiseks.</p> <p>b) HOIATUS: tegelikult tööriista kasutamisel tekkinud vibratsioonid võivad erineda deklareeritud koguvibratsiooni tasemest sõltuvalt tööriista kasutamise viisist. See pärast tuleb töö ajal kasutuses võtta ohutusmeetodid, millelga töötaajal kaitsta: kanda kasutamise ajal kindaid, piirata masina kasutamise aega ja lühendada perioode, mille vältel hoitakse gaasihooba all.</p>

<p><b>[1] FI - TEKNISET TIEDOT</b></p> <p>[2] Syöttöjännite ja -taajuus MAX</p> <p>[3] Syöttöjännite ja -taajuus NOMINAL</p> <p>[4] Ketjun maksiminopeus</p> <p>[5] Karan maksimipöyrimistaajuus</p> <p>[6] Leikkauksen pituus</p> <p>[7] Ketjun paksuus</p> <p>[8] Ketjun hammasrattaan kapasiteetti / hammasluku</p> <p>[9] Ojyissäiliön tilavuus</p> <p>[10] Paimo (ilman akkuja, terälevyä ja ketjuja)</p> <p>[11] Mittattu äänenpaineen taso</p> <p>[12] Mittauspöyryvarmuus</p> <p>[13] Mittattu äänitehotaso</p> <p>[14] Taattu äänitehotaso</p> <p>[15] Tärinätaaso</p> <p>[16] - Etukahva</p> <p>[17] - Takakahva</p> <p>[18] SAATAVANA OLEVAT LISÄVARUSTEET</p> <p>[19] Akkuyksikkö, malli</p> <p>[20] Akkukaltri</p> <p>[21] TAULUKKO TERÄLEVYN JA KETJUN OIKEA YHDISTELMÄ (luku 15.3)</p> <p>[22] KULKU</p> <p>[23] TERÄLEVY</p> <p>[24] KETJU</p> <p>[25] Tuumat / mm</p> <p>[26] Pituus: Tuumat / cm</p> <p>[27] Uran leveys: Tuumat / mm</p> <p>[28] Koodi</p> <p>a) HUOMAUTUS: tärinän kokonaisarvo on mitattu käytännöllä normalisoitua testimenetelmää ja sitä voidaan käyttää verrattaessa työkaluja keskenään. Tärinän kokonaisarvoa voidaan käyttää myös kun tehdään alitustamista koskeva esiarvio.</p> <p>b) VAROITUS: laitteen tuottama tärinä työvälineen todellisen käytön aikana saattaa poiketa ilmoitetusta kokonaisarvosta käyttötavasta riippuen. Tämän vuoksi on tarpeen selvittää seuraavia käyttäjäjä suojajava turvatoimenpiteitä: käyttää käsinettä käytön aikana, rajoittaa laitteen käyttöaikaa ja yhtenäistä aikoja jolloin kaasuttimen vipua pidetään painettuna.</p>	<p><b>[1] FR - DONNÉES TECHNIQUES</b></p> <p>[2] Tension et fréquence d'alimentation MAX</p> <p>[3] Tension et fréquence d'alimentation NOMINAL</p> <p>[4] Vitesse maximum de la chaîne</p> <p>[5] Fréquence maximum de rotation du mandrin</p> <p>[6] Longueur de coupe</p> <p>[7] Epaisseur de la chaîne</p> <p>[8] Dents / pas du pignon de chaîne</p> <p>[9] Capacité du réservoir d'huile</p> <p>[10] Poids (sans batterie; sans guide-chaîne et chaîne)</p> <p>[11] Niveau de pression acoustique mesuré</p> <p>[12] Incertitude de mesure</p> <p>[13] Niveau de puissance acoustique mesuré</p> <p>[14] Niveau de puissance acoustique garanti</p> <p>[15] Niveau de vibrations</p> <p>[16] - Poignée avant</p> <p>[17] - Poignée arrière</p> <p>[18] EQUIPEMENTS SUR DEMANDE</p> <p>[19] Groupe de batteries, mod.</p> <p>[20] Chargeur de batterie</p> <p>[21] TABLEAU DES COMBINAISONS CORRECTES ENTRE GUIDE-CHAÎNE ET CHAÎNE (Chap. 15.3)</p> <p>[22] PAS</p> <p>[23] GUIDE-CHAÎNE</p> <p>[24] CHAÎNE</p> <p>[25] Pouces / mm</p> <p>[26] Longueur : Pouces / cm</p> <p>[27] Largeur rainure : Pouces / mm</p> <p>[28] Code</p> <p>a) REMARQUE : la valeur totale déclarée des vibrations a été mesurée selon une méthode d'essai normalisée et peut être utilisée pour comparer un outillage avec un autre. La valeur totale des vibrations peut être utilisée aussi pour une évaluation préalable à l'exposition.</p> <p>b) AVERTISSEMENT : l'émission de vibrations lors de l'utilisation effective de l'outillage peut différer de la valeur totale déclarée en fonction des modes d'utilisation de l'outillage. Par conséquent, il est nécessaire, pendant le travail, d'adopter les mesures de sécurité suivantes en vue de protéger l'opérateur : porter des gants durant l'utilisation, limiter les temps d'utilisation de la machine et écouter les temps pendant lesquels le levier de commande de l'accélérateur est enfoncé.</p>	<p><b>[1] HR - TEHNIČKI PODACI</b></p> <p>[2] Napon i frekvencija napajanja MAKS.</p> <p>[3] Napon i frekvencija napajanja NAZIVNI</p> <p>[4] Maksimalna brzina lanca</p> <p>[5] Maksimalna frekvencija vrtnje vretena</p> <p>[6] Dužina košnje</p> <p>[7] Debljina lanca</p> <p>[8] Zupci/korak lančanika</p> <p>[9] Zapremina spremnika ulja</p> <p>[10] Težina (bez baterije, bez vodilice i lanca)</p> <p>[11] Izmjerena razina zvučnog tlaka</p> <p>[12] Mjerna nesigurnost</p> <p>[13] Izmjerena razina zvučne snage</p> <p>[14] Zajamčena razina zvučne snage</p> <p>[15] Razina vibracija</p> <p>[16] - Prednja ručka</p> <p>[17] - Stražnja ručka</p> <p>[18] DODATNA OPREMA PO NARUDŽBI</p> <p>[19] Sklop baterije, mod.</p> <p>[20] Punjač baterija</p> <p>[21] TABLICA ZA PRAVILNO KOMBINIRANJE VODILICE I LANCA (pog. 15.3)</p> <p>[22] KORAK</p> <p>[23] VODILICA</p> <p>[24] LANAC</p> <p>[25] inča/mm</p> <p>[26] Dužina: inča/cm</p> <p>[27] Širina žlijeba: inča/mm</p> <p>[28] Šifra</p> <p>a) NAPOMENA: izmjerena ukupna vrijednost vibracija izmjerena je pridržavajući se normirane probne metode i može se koristiti za usporedbu jednog alata s drugim. Ukupna vrijednost vibracija može se koristiti i u preliminarnoj procjeni izloženosti.</p> <p>b) UPOZORENJE: emisija vibracija pri stvarnoj uporabi alata može se razlikovati od izvijene ukupne vrijednosti, ovisno o načinima korištenja alata. Stoga je za vrijeme rada potrebno poduzeti sljedeće sigurnosne mjere namijenjene zaštiti rukovatelja: nositi rukavice tijekom uporabe, ograničiti vrijeme korištenja stroja te skratiti vrijeme držanja pristenje upravljačke ručice gasa.</p>
<p><b>[1] HU - MŰSZAKI ADATOK</b></p> <p>[2] MAX hálózáti feszültség és frekvencia</p> <p>[3] NÉVLEGES hálózáti feszültség és frekvencia</p> <p>[4] LANC max. sebessége</p> <p>[5] A tokmány maximális forgási sebessége</p> <p>[6] Vágás hossza</p> <p>[7] LANC vastagsága</p> <p>[8] LANC fogaskerek fogai / osztása</p> <p>[9] Az olajtartály kapacitása</p> <p>[10] Súly (akkumulátor, vezetőlemez és lánccső nélkül)</p> <p>[11] Mért hangnyomás szint</p> <p>[12] Mérési bizonytalanság</p> <p>[13] Mért egyenértékű hangnyomás szint</p> <p>[14] Garantált zajteljesítmény szint</p> <p>[15] Vibrációs szint</p> <p>[16] - Elűlső markolat</p> <p>[17] - Hátsó markolat</p> <p>[18] RENDELHETŐ KIEGÉSZÍTŐK</p> <p>[19] Akkumulátor-egység, típus</p> <p>[20] Akkumulátor-töltő</p> <p>[21] TÁBLÁZAT A HELYES VEZETŐLEMEZ-LANCCOMBINÁCIÓ MEGÁLLAPÍTÁSÁHOZ (15.3. feje.)</p> <p>[22] OSZTÁS</p> <p>[23] VEZETŐLEMEZ</p> <p>[24] LANC</p> <p>[25] Hűvelék / mm</p> <p>[26] Hosszúság: Hűvelék / cm</p> <p>[27] Vájt szélesség: Hűvelék / mm</p> <p>[28] Kód</p> <p>a) MEGJEGYZÉS: a rezgés névleges összértékét szabványos teszt módszerrel mértük, ezért alkalmazható más szerszámokkal való összehasonlításra. A rezgés névleges összértéke a kitettés előzetes értékelésére is alkalmas.</p> <p>b) FIGYELMEZTETÉS: a szerszám való használata során keletkező rezgés eltérhet a névleges összértéktől a szerszám használati módjának függvényében. Ezért a munka alatt alkalmazni kell a kezelő védelméltől alag biztonsági intézkedéseket: viseljen munkakesztyűt a használat során, korlátozza a gép használati idejét és lehetőleg rövid ideig tartsa nyomva a gázkart.</p>	<p><b>[1] LT - TECHINIAI DUOMENYS</b></p> <p>[2] Maksimali malinimo įtampa ir dažnis</p> <p>[3] NOMINALI malinimo įtampa ir dažnis</p> <p>[4] Grandinės maksimalus greitis</p> <p>[5] Maksimalus griebtuvo sukimosi greitis</p> <p>[6] Pjovimo ilgis</p> <p>[7] Grandinės storis</p> <p>[8] Dantys / grandinės žvaigždutės žingsnis</p> <p>[9] Alyvos bako talpa</p> <p>[10] Svoris (be akumulatoriaus, be strypo ir grandinės)</p> <p>[11] Išmatuotas garso slėgio lygis</p> <p>[12] Matavimo paklaida</p> <p>[13] Išmatuotas garso galios lygis</p> <p>[14] Garantuotas garso galios lygis</p> <p>[15] Vibracijų lygis</p> <p>[16] - Priekinė rankena</p> <p>[17] - Galinė rankena</p> <p>[18] UŽSAKOMI PRIEDAI</p> <p>[19] Akumulatoriaus blokas, mod.</p> <p>[20] Akumulatoriaus įkroviklis</p> <p>[21] LENTELE TINKAMAM STRYPO IR GRANDINĖS SUDERINIMUI ( 15.3 skyr.)</p> <p>[22] EIGA</p> <p>[23] STRYPAS</p> <p>[24] GRANDINĖ</p> <p>[25] Coliai / mm</p> <p>[26] Ilgis: Coliai / cm</p> <p>[27] Griovelių plotis: Coliai / mm</p> <p>[28] Kodas</p> <p>a) PASTABA: bendras deklaruojamas vibracijų lygis buvo išmatuotas laikantis standartizuoto bandymo metodo ir gali būti naudojamas lyginant vieną įrankį su kitu. Bendras vibracijų lygis gali būti naudojamas preliminariam vibracijų įvertinimui.</p> <p>b) ĮSPĖJIMAS: vibracijų skleidimo lygis eksploatuojant įrenginį gali skirtis nuo bendro deklaruojamo vibracijų lygio, priklausomai nuo būdų, kaip bus naudojami įrankis. Dėl šios priežasties darbu metu yra būtina imtis saugios priemonių, susijusių su operatoriaus apsauga: naudojuo metu mūvėti pirštines, riboti įrenginio darbo trukmę ir trumpinti laiką, kurio metu būna paspausta akceleratoriaus valdymo svirtis.</p>	<p><b>[1] LV - TEHNISKE DATI</b></p> <p>[2] MAKS. barošanas spriegums un frekvence</p> <p>[3] NOMINĀLAIS barošanas spriegums un frekvence</p> <p>[4] Maksimālais ķēdes ātrums</p> <p>[5] Maksimālais patronas griešanās ātrums</p> <p>[6] Plaušanas garums</p> <p>[7] Kēdes biežums</p> <p>[8] Kēdes zobrata zobi/solis</p> <p>[9] Elias ivertnes tilpums</p> <p>[10] Svārs (bez akumulatora, sliedes un ķēdes)</p> <p>[11] Izmēritais skaņas spiediena līmenis</p> <p>[12] Mērijuma kļūda</p> <p>[13] Izmēritais akustiskās jaudas līmenis</p> <p>[14] Garantētais akustiskās jaudas līmenis</p> <p>[15] Vibrāciju līmenis</p> <p>[16] - Priekšējais rokturis</p> <p>[17] - Aizmugurējais rokturis</p> <p>[18] PIEDERŪMI PEC PASŪTĪJUMA</p> <p>[19] Akumulatora mezgls, mod.</p> <p>[20] Akumulatoru lādētājs</p> <p>[21] SLIEZU UN KĒZU PAREIZU KOMBINĀCIJU TABULA (15.3 nod.)</p> <p>[22] SOLIS</p> <p>[23] SLIEDE</p> <p>[24] KĒDE</p> <p>[25] Collas / mm</p> <p>[26] Garums: Collas / cm</p> <p>[27] Rievas platums: Collas / mm</p> <p>[28] Kods</p> <p>a) PIEZĪME: kopējā norādītā vibrāciju intensitātes vērtība tika izmērīta, izmantojot standartā pārbaudus metodi, un to var izmantot ierīču savstarpējai salīdzināšanai. Kopējā vibrāciju intensitātes vērtību var izmantot arī sākotnējai ekspozīcijas novērtēšanai.</p> <p>b) BRĪDĪNĀJUMS: vibrāciju līmenis ierīces faktiskās izmantošanas laikā var atšķirties no kopējās norādītās vērtības, atkarībā no ierīces izmantošanas veida. Tāpēc darba laikā ir svarīgi izmantot šādus operatora aizsardzības līdzekļus: izmantošanas laikā valkājiet cimdus, ierobežojiet mašīnas izmantošanas laiku un saīsiniet laiku, kurā akceleratora vadības svira atrodas nospieštas stāvoklī.</p>

<p>[1] <b>МК - ТЕХНИЧКИ ПОДАТОЦИ</b></p> <p>[2] Волтажа и вид напојување МАКС</p> <p>[3] Волтажа и вид напојување НОМИНАЛНО</p> <p>[4] Максимална моќност на синџиот</p> <p>[5] Максимална фреквенција на ротација на моторот</p> <p>[6] Должина на сечење</p> <p>[7] Длабочина на синџиот</p> <p>[8] Запци/ степен на запченикот на синџиот</p> <p>[9] Капацитет на резервоарот за масло</p> <p>[10] Тежина (без акумулатор, без лост и ланџи)</p> <p>[11] Ниво на измерена акустичен притисок</p> <p>[12] Отстапување при мерење</p> <p>[13] Ниво на измерена акустична моќност</p> <p>[14] Ниво на гарантирана акустична моќност</p> <p>[15] Ниво на вибрации</p> <p>[16] - Предна рачка</p> <p>[17] - Задна рачка</p> <p>[18] ДОПОЛНИТЕЛНА ОПРЕМА ПО ИЗБОР</p> <p>[19] Комплет со батерија, модел</p> <p>[20] Полнач за батерија</p> <p>[21] ТАБЕЛА ЗА ПРАВИЛНА КОМБИНАЦИЈА НА ЛОСТОВИ И СИНџИРИ (поглавје 15.3)</p> <p>[22] ОД</p> <p>[23] ЛОСТ</p> <p>[24] СИНџИР</p> <p>[25] инчи / мм</p> <p>[26] Должина: инчи / см</p> <p>[27] Ширина на жлеб: инчи / мм</p> <p>[28] Код</p> <p>a) ЗАБЕЛЕШКА: вкупната посочена вредност за вибрациите е измерена со пробен метод за нормализирање и може да се користи за споредбена вредност на еден уред со друг. Вкупната вредност на вибрациите може да се користи и за прелиминарна проценка на безбедноста.</p> <p>b) ВНИМАНИЕ: емисијата на вибрациите при ефикасна употреба може да се разликува од вкупната посочена вредност според начинот на употреба на уредот. Затоа е неопходно во текот на работата да се направат поевке безбедности и мерења за да се заштити операторот: носете чевли во текот на употребата, ограничете го времето на употреба на машината и скратете го времето кога треба да се притисне рачката за управување со забрзувачот.</p>	<p>[1] <b>NL - TECHNISCHE GEGEVENS</b></p> <p>[2] Spanning en frequentie voeding MAX</p> <p>[3] Spanning en frequentie voeding NOMINAAL</p> <p>[4] Maximale snelheid van de ketting</p> <p>[5] Maximale rotatiefrequentie van de spindel</p> <p>[6] Lengte van de snit</p> <p>[7] Diepte ketting</p> <p>[8] Tand(en) / steek van het kettingwiel</p> <p>[9] Vermogen van het oliereservoir</p> <p>[10] Gewicht (zonder accu, zonder stang en ketting)</p> <p>[11] Gemeten niveau geluidsdruk</p> <p>[12] Meetonzekerheid</p> <p>[13] Gemeten akoestisch vermogen</p> <p>[14] Gearandeerd geluidsniveau</p> <p>[15] Trillingsniveau</p> <p>[16] - Voorste handgreep</p> <p>[17] - Achterste handgreep</p> <p>[18] OP AANVRAAG LEVERBARE ACCESSOIRES</p> <p>[19] Accugroep, mod.</p> <p>[20] Batterijlader</p> <p>[21] <b>TABEL VOOR DE CORRECTE COMBINATIE VAN STANG EN KETTING (Hdst. 15.3)</b></p> <p>[22] STEEL</p> <p>[23] STANG</p> <p>[24] KETTING</p> <p>[25] Inches / mm</p> <p>[26] Lengte: Inches / cm</p> <p>[27] Breedte gleuf: Inches / mm</p> <p>[28] Code</p> <p>a) <b>OPMERING:</b> de totale verklaarde waarde van de trillingen werd gemeten met een genormaliseerde testmethode en kan gebruikt worden voor een vergelijking tussen twee werktuigen. De totale waarde van de trillingen kan ook gebruikt worden in een voorafgaande evaluatie van de blootstelling.</p> <p>b) <b>WAARSCHUWING:</b> de emissie van trillingen bij het effectief gebruik van het werktuig kan verschillen van de totale verklaarde waarden, al naar gelang de manieren waarop het werktuig gebruikt wordt. Daarom is het noodzakelijk, tijdens het werk, de volgende veiligheidsmaatregelen toe te passen om de bediener te beschermen: handschoenen te gebruiken tijdens het gebruik, het gebruik van de machine te beperken en de de bedieningshendel van de versnellng zo kort mogelijk ingedrukt te houden.</p>	<p>[1] <b>NO - TEKNISKE DATA</b></p> <p>[2] Maks matespenning og -frekvens</p> <p>[3] NOMINELL matespenning og -frekvens</p> <p>[4] Maks kjedehastighet</p> <p>[5] Maksimal rotasjonsfrekvens ved doren</p> <p>[6] Skjærelengde</p> <p>[7] Kjedetykkelse</p> <p>[8] Tenner / trinn fra kjedepinjong</p> <p>[9] Oljetankens kapasitet</p> <p>[10] Vekt (uten batteri, uten sverd og kjede)</p> <p>[11] Målt lydtrykknivå</p> <p>[12] Måleusikkerhet</p> <p>[13] Målt lydeffektivitet</p> <p>[14] Garantert lydeffektivitet</p> <p>[15] Vibrasjonsnivå</p> <p>[16] - Håndtak fremme</p> <p>[17] - Håndtak bak</p> <p>[18] TILBEHØR PÅ FORESPØRSEL</p> <p>[19] Batteri, modell</p> <p>[20] Batterilader</p> <p>[21] <b>TABELL FOR RIKTIG KOMBINASJON AV SVERD OG KJEDE (Kap. 15.3)</b></p> <p>[22] TRINN</p> <p>[23] SVERD</p> <p>[24] KJEDE</p> <p>[25] Tommer / mm</p> <p>[26] Lengde: Tommer / cm</p> <p>[27] Bredderille: Tommer / mm</p> <p>[28] Kode</p> <p>a) <b>MERK:</b> Oppgitt totalverdi for vibrasjoner har blitt målt ved å bruke en normal prøvemotode og kan brukes for å sammenligne et redskap med et annet. Den totale vibrasjonsverdien kan også brukes i en foreløpig eksponeringsvurdering.</p> <p>b) <b>ADVARSEL:</b> emisjon av vibrasjoner ved effektiv bruk av redskapet kan avvike fra oppgitt totalverdi i henhold til måten redskapet brukes på. Derfor er det nødvendig, under arbeidet, å ta i bruk følgende sikkerhetstiltak for å beskytte operatoren: føre seg hanske ved bruk, begrense maskinens brukstid og korte ned på tiden som man holder inne akselerator kommandospaken.</p>
<p>[1] <b>PL - DANE TECHNICZNE</b></p> <p>[2] Napięcie i częstotliwość zasilania MAX</p> <p>[3] Napięcie i częstotliwość zasilania NOMINAL</p> <p>[4] Maksymalna prędkość łańcucha</p> <p>[5] Maksymalna częstotliwość obrotów wrzeciona</p> <p>[6] Długość cięcia</p> <p>[7] Grubość łańcucha</p> <p>[8] Zęby / podziałka koła zębatego łańcucha</p> <p>[9] Pojemność zbiornika oleju</p> <p>[10] Masa (bez akumulatora, bez prowadnicy i łańcucha)</p> <p>[11] Zmierzony poziom mocy ciśnienia</p> <p>[12] Błąd pomiaru</p> <p>[13] Poziom mocy akustycznej zmierzony</p> <p>[14] Gwarantowany poziom mocy akustycznej</p> <p>[15] Poziom wibracji</p> <p>[16] - Uchwyt przedni</p> <p>[17] - Uchwyt tylny</p> <p>[18] AKCESORIA NA ZAMÓWIENIE</p> <p>[19] Zespół akumulatora, mod.</p> <p>[20] Ładowarka akumulatora</p> <p>[21] <b>TABELA PRAWIDŁOWEJ KOMBINACJI PROWADNICY I ŁAŃCUCHA (Rozdz. 15.3)</b></p> <p>[22] SŁÓK</p> <p>[23] PROWADNICA</p> <p>[24] ŁAŃCUCH</p> <p>[25] Cale / mm</p> <p>[26] Długość: Cale / cm</p> <p>[27] Szerokość rowka: Cale / mm</p> <p>[28] Kod</p> <p>a) <b>UWAGA:</b> Całkowita wskazana wartość drgań została zmierzona zgodnie ze znormalizowaną metodą badania i może być wykorzystana w celu dokonania porównania między dwoma urządzeniami. Całkowita wartość drgań może być również stosowana do wstępnej oceny zagrożenia.</p> <p>b) <b>OSTRZEŻENIE:</b> emisja drgań w praktycznym zastosowaniu niniejszego narzędzia może się różnić od deklarowanej wartości łącznej, w zależności od sposobu użytkowania urządzenia. Dlatego, w celu zapewnienia bezpieczeństwa użytkownika, konieczne jest podczas pracy z urządzeniem podjęcie następujących środków bezpieczeństwa: noszenie rękawic ochronnych z urządzeniem, ograniczenie czasu użytkowania urządzenia i skrócenie czasu trzymania wciśniętej dźwigni regulacji obrotów silnika.</p>	<p>[1] <b>PT - DADOS TÉCNICOS</b></p> <p>[2] Tensão e frequência de alimentação MÁX</p> <p>[3] Tensão e frequência de alimentação NOMINAL</p> <p>[4] Velocidade máxima da corrente</p> <p>[5] Frequência máxima de rotação do mandral</p> <p>[6] Comprimento de corte</p> <p>[7] Espessura corrente</p> <p>[8] Dentes / distância entre eixos do pinhão da corrente</p> <p>[9] Capacidade do tanque do óleo</p> <p>[10] Peso (sem bateria, sem barra e corrente)</p> <p>[11] Nivel de pressão acústica mensurada</p> <p>[12] Incerteza de medição</p> <p>[13] Nivel de potência acústica mensurado</p> <p>[14] Nivel de potência acústica garantido</p> <p>[15] Nivel de vibrações</p> <p>[16] - Pega dianteira</p> <p>[17] - Pega traseira</p> <p>[18] <b>ACCESÓRIOS A PEDIDO</b></p> <p>[19] Grupo bateria, mod.</p> <p>[20] Carregador de bateria</p> <p>[21] <b>TABELA PARA A CORRENTE COMBINAÇÃO DE BARRA E CORRENTE (Cap. 15.3)</b></p> <p>[22] PALAÇO</p> <p>[23] BARRA</p> <p>[24] CORRENTE</p> <p>[25] Polegadas / mm</p> <p>[26] Comprimento: Polegadas / cm</p> <p>[27] Largura sulco: Polegadas / mm</p> <p>[28] Código</p> <p>a) <b>NOTA:</b> o valor total declarado das vibrações foi mensurado de acordo com um método normalizado de ensaio e pode ser utilizado para comparar uma ferramenta com a outra. O valor total das vibrações também pode ser utilizado para uma avaliação preliminar da exposição.</p> <p>b) <b>ADVERTÊNCIA:</b> a emissão de vibrações no uso efetivo da ferramenta pode ser diversa do valor total declarado de acordo com os modos com os quais a ferramenta é utilizada. Portanto, durante o trabalho, é necessário adotar as seguintes medidas de segurança para proteger o operador: usar luvas durante o uso, limitar o tempo de utilização da máquina e encurtar o tempo durante o qual a alavanca de comando é mantida pressionada.</p>	<p>[1] <b>RO - DATE TEHNICE</b></p> <p>[2] Tensiune și frecvență de alimentare MAX</p> <p>[3] Tensiune și frecvență de alimentare NOMINAL</p> <p>[4] Viteza maximă a lanțului</p> <p>[5] Frecvență maximă de rotație a mandrinei</p> <p>[6] Lungimea tăieturii</p> <p>[7] Grosimea lanțului</p> <p>[8] Dinți / pas pinion lanț</p> <p>[9] Capacitate rezervor ulei</p> <p>[10] Greutate (fără baterie, fără bară și lanț)</p> <p>[11] Nivel măsurat de presiune acustică</p> <p>[12] Nesigurarea în măsurare</p> <p>[13] Nivel de putere acustică măsurat</p> <p>[14] Nivel de putere acustică garantat</p> <p>[15] Nivel de vibrații</p> <p>[16] - Mâner față</p> <p>[17] - Mâner spate</p> <p>[18] <b>ACCESORII LA CERERE</b></p> <p>[19] Ansamblu baterie, mod.</p> <p>[20] Alimentator pentru baterie</p> <p>[21] <b>TABELA PENTRU O ASOCIERE CORECTĂ BARRĂ-LANȚ (Cap. 15.3)</b></p> <p>[22] PAS</p> <p>[23] BARRĂ</p> <p>[24] LANȚ</p> <p>[25] Inchi / mm</p> <p>[26] Lungime: Inchi / cm</p> <p>[27] Lățimea canalei: Inchi / mm</p> <p>[28] Cod</p> <p>a) <b>OBSERVAȚIE:</b> valoarea totală declarată a vibrațiilor a fost măsurată ținându-se cont de o metodă de probă normalizată și poate fi utilizată pentru a compara instrumentele între ele. Valoarea totală a vibrațiilor poate fi utilizată și pentru o evaluare preliminară a expunerii.</p> <p>b) <b>AVERTISMENT:</b> emisia de vibrații în utilizarea efectivă a instrumentului poate fi diferită față de valoarea totală declarată, în funcție de modul în care se adoptează instrumentul. Din acest motiv este nevoie ca, în timpul sesiunii de lucru, să se adopte următoarele măsuri de siguranță menite să protejeze operatorul: purtarea mănușilor în timpul utilizării, limitarea duratei de utilizare a mașinii și scurtarea duratei în care se ține apăsată maneta de comandă a accelerației.</p>

<p>[1] <b>RU - ТЕХНИЧЕСКИЕ ХАРАКТЕРИСТИКИ</b></p> <p>[2] Напряжение и частота питания МАКС.</p> <p>[3] Напряжение и частота питания НОМИНАЛЬНЫЕ</p> <p>[4] Максимальная скорость цепи</p> <p>[5] Максимальная частота вращения шпинделя</p> <p>[6] Длина пильного аппарата</p> <p>[7] Толщина цепи</p> <p>[8] Зубцы / шаг звездочки цепи</p> <p>[9] Емкость масляного бака</p> <p>[10] Вес (без батареи, шины и цепи)</p> <p>[11] Измеренный уровень звуковой давления</p> <p>[12] Погрешность измерения</p> <p>[13] Измеренный уровень звуковой мощности</p> <p>[14] Гарантируемый уровень звуковой мощности</p> <p>[15] Уровень вибрации</p> <p>[16] - Передняя рукоятка</p> <p>[17] - Задняя рукоятка</p> <p>[18] <b>ДОПОЛНИТЕЛЬНОЕ ОБОРУДОВАНИЕ ПО ТРЕБОВАНИЮ</b></p> <p>[19] Батарейный блок, мод.</p> <p>[20] Зарядное устройство</p> <p>[21] <b>ТАБЕЛА ЗА ПРАВИЛНО КОМБИНАЦИЈ ШИНА-ЦЕПЬ (п. 15.3)</b></p> <p>[22] ШАГ</p> <p>[23] ШИНА</p> <p>[24] ЦЕПЬ</p> <p>[25] дюймы / мм</p> <p>[26] Длина; дюймы / см</p> <p>[27] Ширина выемки; дюймы / мм</p> <p>[28] Код</p> <p>a) ПРИМЕЧАНИЕ: общий заявленный уровень вибрации был измерен с использованием нормализованного метода испытаний, и его можно использовать для сравнения различных инструментов между собой. Общий уровень вибрации можно также использовать для предварительной оценки подверженности воздействию вибрации.</p> <p>b) ПРЕДУПРЕЖДЕНИЕ: уровень вибрации во время фактической эксплуатации инструмента может отличаться от общего заявленного значения и зависит от режимов эксплуатации инструмента. Поэтому во время работы необходимо принимать следующие меры безопасности для защиты оператора: работать в перчатках, ограничивать время использования машины и сокращать время, в течение которого рычаг управления дросселем остается нажатым.</p>	<p>[1] <b>SK - TECHNICKÉ PARAMETRE</b></p> <p>[2] MAX. napájacie napätie a frekvencia</p> <p>[3] MENOVITÉ napätie a frekvencia</p> <p>[4] Maximálna rýchlosť reťaze</p> <p>[5] Maximálna frekvencia otáčania vretena</p> <p>[6] Rezná dĺžka</p> <p>[7] Hrubica reťaze</p> <p>[8] Zuby / rozstup reťazovky</p> <p>[9] Kapacita olejovej nádrže</p> <p>[10] Hmotnosť (bez akumulátora, vodiacej lišty a reťaze)</p> <p>[11] Nameraná úroveň akustického tlaku</p> <p>[12] Nepravosť merania</p> <p>[13] Nameraná úroveň akustického výkonu</p> <p>[14] Zarúčena úroveň akustického výkonu</p> <p>[15] Úroveň vibrácií</p> <p>[16] - Predná rukoväť</p> <p>[17] - Zadná rukoväť</p> <p>[18] <b>VOLITELNÉ PRISLUŠENSTVO</b></p> <p>[19] Akumulátorová jednotka, MOD.</p> <p>[20] Nabíjacia akumulátora</p> <p>[21] <b>TABUĽKA PRE URČENIE SPRÁVNEJ KOMBINÁCIE VODIACEJ LIŠTY A REŤAZE (kap. 15.3)</b></p> <p>[22] ROZSTUP</p> <p>[23] VODIACA LIŠTA</p> <p>[24] REŤAZ</p> <p>[25] Palce / mm</p> <p>[26] Dĺžka; Palce / cm</p> <p>[27] Šírka drážky; Palce / mm</p> <p>[28] Kód</p> <p>a) POZNAMKA: vyhlásené celkové hodnoty vibrácií bola nameraná s použitím normalizovanej skúsobnej metódy a je možné ju použiť na porovnanie jednotlivých nástrojov. Celkové hodnoty vibrácií môže byť použitá aj pri prípravnom vyhodnocovaní vibrácií.</p> <p>b) VAROVANIE: emisia vibrácií pri skutočnom použití nástroja môže byť odlišná od vyhlásenej celkovej hodnoty v závislosti na režimoch, v ktorých sa daný nástroj používa. Preto je potrebné počas práce prijať vhodné opatrenia, ktoré majú za cieľ ochrániť operátora: počas bežného používania majte nasadené rukavice, obmedzte dobu použitia stroja a skráťte dobu, počas ktorej je zatlačená ovládací páka plynu.</p>	<p>[1] <b>SL - TEHNIČNI PODATKI</b></p> <p>[2] Napetost in frekvenca električnega napajanja</p> <p>[3] - MAX</p> <p>[4] Napetost in frekvenca električnega napajanja</p> <p>[5] - NAZIVNA</p> <p>[6] Maksimalna hitrost verige</p> <p>[7] Maksimalna frekvenca rotacije vretena</p> <p>[8] Dolžina reza</p> <p>[9] Debelina verige</p> <p>[10] Zobniki / hod verižnega pastorka</p> <p>[11] Kapaciteta rezervoarja za olje</p> <p>[12] Teža (brez baterije, brez meča in verige)</p> <p>[13] Izmerjena raven zvočnega tlaka</p> <p>[14] Nezasledljivost meritve</p> <p>[15] Izmerjena raven zvočne moči</p> <p>[16] Zagotovljena raven zvočnega tlaka</p> <p>[17] Nivo vibracij</p> <p>[18] - Prednji ročaj</p> <p>[19] - Zadnji ročaj</p> <p>[20] <b>DODATNA OPREMA PO NAROČILU</b></p> <p>[21] Sklop baterije, mod.</p> <p>[22] Polnilnik baterije</p> <p>[23] <b>TABELA ZA PRAVILNO KOMBINACIJO MEČA IN VERIGE (Pogl. 15.3)</b></p> <p>[24] KORAK</p> <p>[25] MEC</p> <p>[26] VERIGA</p> <p>[27] Palci / cm</p> <p>[28] Dolžina; Palci / cm</p> <p>[29] Širina utor: Palci / cm</p> <p>[30] Šifra</p> <p>a) OPOMBA: Deklarirana skupna vrednost vibracij je bila izmerjena v skladu z normirano metodo preizkušanja; mogoče jo je uporabiti za primerjavo med različnimi orodji. Skupna vrednost vibracij se lahko uporabi tudi za predhodno oceno izpostavitve.</p> <p>b) OPOZORILO: Med dejansko uporabo orodja se oddajane vibracije lahko razlikujejo od deklarirane skupne vrednosti, kar je odvisno od načina uporabe orodja. Zato je treba med delom udeležajati naslednje varnostne ukrepe za zaščito upravljalca: med delom nosite rokavice, omejite čas uporabe stroja in skrajšajte intervale, med katerimi pritisnete na komandni vzvod pospeševalnika.</p>
<p>[1] <b>SR - TEHNIČKI PODACI</b></p> <p>[2] MAKS. napon i frekvencija napajanja</p> <p>[3] NAZIVNI napon i frekvencija napajanja</p> <p>[4] Maksimalna brzina lanca</p> <p>[5] Maksimalna frekvencija okretanja vretena</p> <p>[6] Dužina sečenja</p> <p>[7] Debljina lanca</p> <p>[8] Zubi / korak zupčanika lanca</p> <p>[9] Kapacitet rezervoara za ulje</p> <p>[10] Težina (bez baterije, bez meča i lanca)</p> <p>[11] Izmereni nivo zvučnog pritiska</p> <p>[12] Merna nesigurnost</p> <p>[13] Izmereni nivo zvučne snage</p> <p>[14] Garantovani nivo zvučne snage</p> <p>[15] Nivo vibracija</p> <p>[16] - Prednja drška</p> <p>[17] - Zadnja drška</p> <p>[18] <b>DODATNI PRIBOR PO NARUĐBINI</b></p> <p>[19] Baterija, mod.</p> <p>[20] Punjač baterije</p> <p>[21] <b>TABELA ZA PRAVILNU KOMBINACIJU MAČA I LANCA (Poglj. 15.3)</b></p> <p>[22] KORAK</p> <p>[23] MAČ</p> <p>[24] LANAC</p> <p>[25] Inč / mm</p> <p>[26] Dužina; Inč / mm</p> <p>[27] Širina zleba; Inč / mm</p> <p>[28] Šifra</p> <p>a) NAPOMENA: ukupna prijavljena vrednost vibracija izmerena je prema normalizovanoj metodi ispitivanja i može se koristiti za poredenje dve alatke. Ukupna vrednost vibracija može se koristiti i prilikom uvodne procene izloženosti.</p> <p>b) UPOZORENJE: emisija vibracija prilikom efektivne upotrebe alatke može se zaključivati od ukupne prijavljene vrednosti u zavisnosti od načina na koji se koristi alatka. Stoga je potrebno, za vreme rada, primeniti sledeće sigurnosne mere u cilju zaštite radnika: nositi rukavice za vreme upotrebe, smanjiti vreme korišćenja mašine i skratiti vreme pritiskanja poluge komande gasa.</p>	<p>[1] <b>SV - TEHNIŠKA DATA</b></p> <p>[2] MAX utspänning och</p> <p>[3] ström-försörjnings-frekvens</p> <p>[4] NOMINELL utspänning och</p> <p>[5] ström-försörjnings-frekvens</p> <p>[6] Kedjans maximala hastighet</p> <p>[7] Spindelns maximala rotations-frekvens</p> <p>[8] Beskärningsens längd</p> <p>[9] Kedjan tjocklek</p> <p>[10] Tänder/kuggstångens tandavstånd på kedjan</p> <p>[11] Oljetankens kapacitet</p> <p>[12] Vikt (utan batteri, utan svärd och kedja)</p> <p>[13] Uppmått ljudtrycknivå</p> <p>[14] Tvivel med mått</p> <p>[15] Mått ljudeffektivtå</p> <p>[16] Garanterad ljudeffektivtå</p> <p>[17] Vibrationsnivå</p> <p>[18] - Främre handtag</p> <p>[19] - Bakre handtag</p> <p>[20] TILLBEHÖR PÅ BESTÄLLNING</p> <p>[21] Batterienhet, mod.</p> <p>[22] Batteriladdare</p> <p>[23] <b>TABELL FÖR RÄTT KOMBINATION AV SVÄRD OCH KEDJA (Kap. 15.3)</b></p> <p>[24] TANDAVSTÅND</p> <p>[25] STÅNG</p> <p>[26] KEDJA</p> <p>[27] Tum/ cm</p> <p>[28] Längd; Tum/ cm</p> <p>[29] Spårbredd; Tum/ cm</p> <p>[30] KOD</p> <p>a) ANMÄRKNING: det totala angivna vibrationsvärdet har mätts i enlighet med en standardiserad testmetod och kan användas för en jämförelse mellan olika verktyg. Det totala vibrationsvärdet kan användas även vid en preliminär exponeringsbedömning</p> <p>b) VARNING: vibrationsmissioner under användningen av verktyget kan skilja sig från det totala värdet som anges beroende på hur verktyget används. Därför är det nödvändigt, under arbetet, att tillämpa de följande säkerhetsåtgärderna som avses för att skydda föraren: bär handskar under användningen, begränsa användningstiden och tiderna som gasreglaget spak hålls nedtryckt.</p>	<p>[1] <b>TR - TEHNIK VERILER</b></p> <p>[2] MAKS besleme gerilimi ve frekansı</p> <p>[3] NOMINAL besleme gerilimi ve frekansı</p> <p>[4] Maksimum zincir hızı</p> <p>[5] İki mili dönüştü azami frekansı</p> <p>[6] Kesim uzunluğu</p> <p>[7] Zincir kalınlığı</p> <p>[8] Zincir pinyonunun dişleri / adımı</p> <p>[9] Yağ deposu kapasitesi</p> <p>[10] Ağırlik (batariasız, pala ve zincir olmadan)</p> <p>[11] Ölçülen ses basıncı seviyesi</p> <p>[12] Ölçüm belirsizliği</p> <p>[13] Ölçülen ses gücü seviyesi</p> <p>[14] Garantili edilen ses gücü seviyesi</p> <p>[15] Titreşim seviyesi</p> <p>[16] - Ön kabza</p> <p>[17] - Arka kabza</p> <p>[18] <b>TALEP UZERINE TEDARIK EDILEN AKSESUARLAR</b></p> <p>[19] Batarya grubu, mod.</p> <p>[20] Batarya şarj cihazı</p> <p>[21] <b>DOĞRU PALA VE ZİNCİR BİRLEŞİMİ İÇİN TABLO (Böl. 15.3)</b></p> <p>[22] ADIM</p> <p>[23] PALA</p> <p>[24] ZİNCİR</p> <p>[25] İnç / mm</p> <p>[26] Uzunluk; İnç / cm</p> <p>[27] Çuyuk genişliği; İnç / mm</p> <p>[28] Kod</p> <p>a) NOT: beyan edilmiş toplam titreşim değeri, normalize edilmiş test yönteminde uygun şekilde ölçülmüştür ve bir takım ile diğer arasında karşılaştırma yapmak amacıyla kullanılabılır. Toplam titreşim değeri aynı zamanda maruz kalma durumuna dair ön değerlendirmeye yarkapan de kullanılabılır.</p> <p>b) UYARI: takrim etkilii kalınlamı sırasında yayılan titreşim, takrim kullanımla sekline bağlı olarak beyan edilmiş toplam değerdan farklı olabilir. Bu nedenle, çalışma yapılrken operatörü korumaya yönelik asadıkları güvenlik tedbirleri almmalıdır: kullanan sırasında edildiren takım, makinemin kullandığı direksi sınırladiren ve gaz kumanda levyesinin basılı tutulduğu süreleri kısalıtın.</p>



**TABLE OF CONTENTS**

1. GENERAL ASPECTS .....	1
2. SAFETY REGULATIONS.....	1
3. GETTING TO KNOW THE MACHINE.....	5
3.1 Description of the machine and planned use .....	5
3.2 Main components (fig. 1).....	6
3.3 Identification label (fig. 1) .....	6
3.4 Safety signs (fig. 2).....	6
4. ASSEMBLY.....	7
4.1 Unpacking.....	7
4.2 Assembly of the guide bar and toothed chain .....	7
4.3 Assembly of Pruner device.....	8
4.4 Extension of the Pruner device.....	8
4.5 Removing the Pruner device .....	8
5. CONTROLS.....	8
5.1 Throttle trigger lever .....	8
5.2 Throttle lock button .....	8
6. USING THE MACHINE .....	8
6.1 Preliminary procedures .....	8
6.2 Safety checks.....	9
6.3 Start-up.....	9
6.4 Working.....	9
6.5 Advice for operation .....	10
6.6 Stop .....	10
6.7 After use.....	11
7. MAINTENANCE .....	11
7.1 General information.....	11
7.2 Battery .....	11
7.3 Topping up the chain oil tank.....	11
7.4 Cleaning.....	12
7.5 chain catcher.....	12
7.6 Machine and bar lubrication holes .....	12
7.7 Nuts and bolts.....	12
7.8 Chain drive sprocket .....	12
7.9 Maintenance of the toothed chain .....	12
7.10 Guide bar maintenance.....	13
8. STORING .....	13
8.1 Storing the machine .....	13
8.2 Storing the battery.....	13
9. HANDLING AND TRANSPORTATION .....	13
10. ASSISTANCE AND REPAIRS.....	13
11. WARRANTY COVERAGE .....	13
12. TROUBLESHOOTING.....	14
13. ATTACHMENTS ON REQUEST .....	16
13.1 Battery .....	16
13.2 Battery charger .....	16
13.3 Bars and chains .....	16

**1. GENERAL ASPECTS****1.1 HOW TO READ THE MANUAL**

**NOTE** or **IMPORTANT** These give details or further information on what has been previously indicated and aim to prevent damage to the machine or cause other damage.

The  symbol highlights danger. Failure to observe the warning can lead to the risk of injury to oneself and others and/or damage.

The paragraphs inside a grey dotted frame refer to optional features not available on all the models referred to in this booklet. Check if the feature is available on your model.

Whenever reference is made to a position on the machine "front", "back", "left" or "right" hand side, this refers to the operator's working position.

**2. SAFETY REGULATIONS****2.1 GENERAL SAFETY WARNINGS**

 **Read all safety warnings, instructions, illustrations and specifications, provided with this power tool. Failure to follow all instructions listed below may result in electric shock, fire and/or serious injury.**

**Save all warnings and instructions for future reference.**

The term "power tool" in the warnings refers to your mains-operated (corded) power tool or battery-operated (cordless) power tool.

**1) Work area safety**

- Keep work area clean and well lit.**  
*Cluttered or dark areas invite accidents.*
- Do not operate power tools in explosive atmospheres, such as in the presence of flammable liquids, gases or dust.** Power tools create sparks which may ignite the dust or fumes.
- Keep children and bystanders well away while using power tools.**  
*Distractions can cause you to lose control.*

## 2) Electrical safety

- a) **Avoid body contact with earthed or grounded surfaces, such as pipes, radiators, cookers and refrigerators.**  
*There is an increased risk of electric shock if your body is earthed or grounded.*
- b) **Do not expose power tools to rain or wet environments.** *Water entering a power tool will increase the risk of electrical shock.*

## 3) Personal safety

- a) **Stay alert, check what you are doing and use common sense when using a power tool. Do not use the power tool when you are tired or under the influence of drugs, alcohol or medicines.** *A moment of inattention while operating a power tool may result in serious personal injury.*
- b) **Use personal protective equipment. Always wear eye protection.** *Protective equipment such as a dust mask, non-skid safety shoes, hard hat or hearing protection used for appropriate conditions will reduce personal injuries.*
- c) **Prevent unintentional starting. Make sure the appliance is turned off before inserting the battery pack, picking up or carrying the power tool.** *Carrying power tools with your finger on the switch or mounting the battery with the switch in "ON" position invites accidents.*
- d) **Remove any adjusting key or wrench before turning the power tool on.** *A wrench or a key left attached to a rotating part of the machine may result in personal injury.*
- e) **Do not overreach. Keep proper footing and balance at all times.** *This enables better control of the power tool in unexpected situations.*
- f) **Dress properly. Do not wear loose clothing or jewellery. Keep your hair and clothing away from moving parts.** *Loose clothes, jewellery or long hair can be caught in moving parts.*
- g) **If devices are provided for the connection of dust extraction and collection facilities, ensure these are connected and properly used.** *Use of dust collection can reduce dust-related hazards.*
- h) **Do not let familiarity gained from frequent use of tools allow you to become complacent and ignore tool safety principles.** *A careless action can cause severe injury within a fraction of a second.*

## 4) Power tool use and care

- a) **Do not force the power tool. Use the correct power tool for your application.** *The correct power tool will do the job better and safer at the speed for which it was designed.*
- b) **Do not use the power tool if the switch does not turn it on and off.** *Any power tool that cannot be controlled with the switch is dangerous and must be repaired.*
- c) **Remove the battery pack from the machine before making any adjustments, changing accessories or storing the power tool.** *Such preventive safety measures reduce the risk of starting the power tool accidentally.*
- d) **Store idle power tools out of the reach of children and do not allow persons unfamiliar with the power tool or these instructions to operate the machine.** *Power tools are dangerous in the hands of untrained users.*
- e) **Maintain power tools and accessories. Check for misalignment or binding of moving parts, breakage of parts and any other condition that may affect power tool operation.** *In case of damage, the power tool must be repaired before it can be used. Many accidents are caused by poor maintenance.*
- f) **Keep cutting tools sharp and clean.** *Properly maintained cutting tools with sharp cutting edges are less likely to bind and are easier to control.*
- g) **Use the power tool and its accessories in accordance with these instructions, taking into account the working conditions and the task to be performed.** *Using the power tool for operations other than those intended could result in a hazardous situation.*
- h) **Keep handles and grasping surfaces dry, clean and free from oil and grease.** *Slippery handles and grasping surfaces do not allow for safe handling and control of the tool in unexpected situations.*

## 5) Battery tool use and care

- a) **Recharge only with the charger specified by the manufacturer.** *A charger that is suitable for one type of battery pack may create a risk of fire, electric shock, overheating or corrosive liquid to leak from the battery. when used with another battery pack.*

- b) **Use power tools exclusively with specifically designated battery packs.** *Use of any other battery packs may create a risk of injury and fire.*
  - c) **When the battery pack is not in use, keep it away from other metal objects such as paper clips, coins, keys, nails, screws or other small metal objects that may create a connection from one terminal to another.** *Shorting the battery terminals together can cause burns or a fire.*
  - d) **Under abusive conditions, liquid may be ejected from the battery; avoid contact. If contact accidentally occurs, flush with water. If the liquid contacts eyes, seek medical help immediately.** *Fluid ejected from the battery may cause irritation and burns.*
  - e) **Do not use a battery pack or tool that is damaged or modified.** *Damaged or modified batteries may exhibit unpredictable behaviour resulting in fire, explosion or risk of injury.*
  - f) **Do not expose a battery pack or tool to fire or excessive temperature.** *Exposure to fire or temperature above 130 °C may cause explosion.*
  - g) **Charge only at room temperature, between 0° + 45°C. Do not charge the battery pack or tool outside the specified temperature range.** *Charging improperly or at temperatures outside the specified range may damage the battery and increase the risk of fire.*
- 6) **Service**
- a) **Have your power tool serviced by a qualified repair person using only identical replacement parts.** *This will ensure that the safety of the power tool is maintained.*
  - b) **Never service damaged battery packs.** *Service of battery packs should only be performed by the manufacturer or authorized service providers.*

## 2.2 SPECIFIC SAFETY RULES FOR CHAINSAWS AND ELECTRIC CHAINSAWS.

- **Keep all body parts at a distance from the toothed chain when the chainsaw is running. Before starting the chainsaw, check that the toothed chain is not in contact with anything.** *Lack of concentration when using the chainsaw can cause clothes or body parts to get caught up in the toothed chain.*
- **The right hand must always hold the rear grip and the left hand the front grip.** *You should never turn your hands when holding the chainsaw, as this increases the risk of accidents on yourself.*
- **Hold the power tool by insulated gripping surfaces only, because the toothed chain may come in contact with hidden wiring.** *Toothed chain contacting a “live” wire may make exposed metal parts of the power tool “live” and could give the operator an electric shock.*
- **Always wear safety goggles and ear protection. Other protective equipment for the head, hands and feet is also recommended.** *The wearing of protective clothing will reduce accidents caused by hurled workpieces and accidental contact with the toothed chain.*
- **Do not use chainsaws when positioned on a tree.** *Starting a chainsaw when positioned on a tree can cause body injuries.*
- **Keep proper footing and balance at all times, and only use the chainsaw on fixed, secure and flat surfaces.** *Slippery or unstable surfaces such as ladders, can cause loss of balance or control of the chainsaw.*
- **When cutting a branch that is under tension, be alert for spring back.** *When the tension of the wood fibres is released, the branch can spring back and injure the operator and/or kick the chainsaw out of control.*
- **Use extreme caution when cutting small size brush and saplings.** *The slender material may catch in the chainsaw and be whipped towards you and/or pull you off balance.*
- **Carry the chainsaw by the front grip when it is switched off and keep it away from your body. When storing or transporting a chainsaw always use the guide bar cover.** *Correct handling of the chainsaw will reduce the probability of unintended contact with the moving chain.*
- **Follow the instructions concerning lubrication, chain tension and replacement parts.** *Chains with incorrect tension and lubrication can break and increase the risk of kickback.*
- **Keep handles dry, clean and free from oil and grease.** *Greasy and oily handles are slippery and can cause loss of control.*
- **Use the chainsaw to cut wood only. Do not use the chainsaw for purposes for which it is not intended. For example: do not use an chainsaw for cutting plastic, masonry or other non-wood materials.** *Using the chainsaw for operations other than those intended could result in a hazardous situation.*

- **Local regulations may restrict the age of the operator.**



***If something breaks or an accident occurs during work, turn off the motor immediately and move the machine away to prevent further damage; if an accident occurs with injuries or third parties are injured, carry out the first aid measures most suitable for the situation immediately and contact the medical authorities for any necessary health care. Carefully remove any debris which could cause damage or injury to persons or animals if ignored.***



***Prolonged exposure to vibrations can cause injuries and neurovascular disorders (also called “Raynaud’s syndrome” or “white finger”), especially to people suffering from circulation disorders. The symptoms can regard the hands, wrists and fingers and are shown through loss of sensitivity, torpor, itching, pain and discolouring of or structural changes to the skin. These effects can be worsened by low ambient temperatures and/or by gripping the hand grips excessively tightly. If the symptoms occur, the length of time the machine is used must be reduced and a doctor consulted.***

- **Take breaks and change your working position regularly.**
- Improper maintenance, use of non-compliant spare parts or modification of the safety devices can cause damage to the device and cause serious injury to the user.
- Perform cleaning and maintenance before storing the machine after use.
- If the machine has been hit or dropped, make sure it is in good condition before starting it up.
- Remove branches in sections.
- Pay attention to the branches that, once cut, can hit the user and to those that, fallen on the ground, can suffer a kickback.

### **2.3 CAUSES OF KICKBACK AND OPERATOR PROTECTION**

Kickback can occur when the nose or tip of the guide bar touches an object, or when the wood closes in and pinches the chain in the cut.

Contact of the tip can, in certain cases, cause a sudden fast reverse action, pushing the guide bar upwards and backwards towards the operator.

Pinching of the chain along the top of the guide bar can rapidly push the chain back towards the operator.

Both the above reactions may cause loss of control of the saw, which could result in serious injury for operators. Do not rely exclusively on the chainsaw built-in safety devices

Chainsaw users should take additional precautions to eliminate accident or injury risks during cutting operations. Kickback is the result of poor use of the tool and/or incorrect operating procedures or conditions and can be avoided by taking the specific precautions provided below:

- **Hold the saw firmly with both hands, with the thumbs and fingers around the chainsaw grips, and position your body and arms so that you can resist the force of a kickback.** Kickback can be controlled by the operator if all appropriate precautions have been taken. Do not allow the chainsaw to start.
- **Do not fully extend the arms and do not saw above shoulder height.** This helps avoid undesired contact with the ends and allows for more control over the chainsaw in unexpected situations.
- **Only use the guide bar and chains recommended by the manufacturer.** Unsuitable guides and chains can cause the chain to break and/or kickbacks.
- **Follow the manufacturer’s instructions regarding sharpening and maintenance of the chainsaw.** A decrease in the level of depth can cause an increase in kickbacks.
- **Techniques for using the electric chainsaw (battery-operated)** Always observe the safety regulations and use the most suitable cutting techniques according to the work to be performed, following the instructions and examples in the user instructions.
- **Safe carrying of the electric chainsaw (battery-operated)** Whenever the machine is to be handled or transported you must:
  - turn off the motor, wait for the chain to stop and unplug the machine from the mains (remove the battery from its housing);
  - apply the protection bar cover;
  - only hold the machine using the handles and position the bar in the opposite direction to that used during operation;
 When using a vehicle to transport the machine, position it so that it can cause no danger to persons and fasten it firmly in place.
- **Recommendations for first-time users** Before felling or delimiting for the first time, make sure:

- to have been specifically trained to use this type of equipment;
  - to have carefully read the safety regulations and user instructions contained in this manual;
  - you practise first on logs on the ground or attached to trestles, in order to get familiar with the machine and the most suitable cutting techniques.
- **Handling and correct use of battery-operated power tools**
    - a) Make sure that the machine is switched off before inserting the battery. Inserting a battery in an electric device which is switched on can cause accidents.
    - b) Charge battery packs only with the chargers recommended by the manufacturer. Battery chargers are generally specific for each battery type; use with other types can cause fire risks.
    - c) Use only batteries specifically designed for your power tool. The use of other batteries may cause injuries and fire risks.
    - d) Keep all unused batteries at a distance from paper clips, coins, keys, nails, screws or other small metal objects as contact with the same can cause short circuits. Short circuits between battery contacts can lead to explosion or fires.
    - e) Batteries in poor condition can cause liquids to leak. Avoid contact with the liquid. In the case of accidental contact flush with water. If the liquid comes into contact with the eyes, also seek medical advice. Liquid leaking from the battery may cause skin irritation or burns.
    - f) Check that the accumulator is in good condition and there are no signs of damage. Do not use the device with a damaged or worn accumulator.

- Comply with local regulations for the disposal of waste materials
- When the machine is withdrawn from service, do not dispose of it in the environment, but take it to a waste disposal facility in accordance with the local regulations in force.



Do not dispose of electrical equipment with household waste material. In observance of European Directive 2012/19/EU on electrical and electronic equipment waste and its

implementation, in observance of UK Regulation “The waste electrical and electronic equipment regulations 2013 (as amended)” and in accordance with national regulations, electrical equipment that has reached the end of its product life must be collected separately and recycled in an ecologically compatible way. If electrical equipment is disposed of in dumps or in landfills, hazardous substances can leak into the groundwater and contaminate the food chain, damaging your health and well-being. For further information on the disposal of this product, contact your dealer or a domestic waste collection service.



Li-ion

At the end of their working life, dispose of batteries paying due attention to the environment. Batteries contain material classified as hazardous for you and the environment. They must be removed and disposed of separately at a facility that accepts lithium-ion batteries.



Separate waste collection of the products and packaging used allows the materials to be recycled and reused. Reuse of recycled materials help to prevent environmental pollution and reduces the demand for raw materials.

## 2.4 PROTECTING THE ENVIRONMENT

Safeguarding the environment must be a relevant and priority aspect of machine use, of benefit to the community and the environment we live in.

- Avoid being a disturbance to the neighbourhood. Use this machine at reasonable times of the day only (not early morning or late evening when the noise could cause disturbance).
- Comply with local regulations for the disposal of packaging, deteriorated parts or any elements with a strong environmental impact; this waste must not be disposed of as normal waste, it must be separated and taken to specified waste disposal centres where the material will be recycled.

## 3. GETTING TO KNOW THE MACHINE

### 3.1 DESCRIPTION OF THE MACHINE AND PLANNED USE

**This machine is a forestry tool and precisely a battery powered chain pruner.**

The machine is essentially composed of a battery powered motor and a guide bar that takes the power from the battery to the motor which drives the cutting chain.

The operator is able to operate the machine with two hands, using the front and rear hand grips,

and can use the main controls, always remaining at a safe distance from the cutting means.

### 3.1.1 Intended use

This machine was designed and manufactured for:

- delimiting trees with dimensions suitable for the length of the guide bar or wooden objects with the same characteristics;
- used by one operator.

### 3.1.2 Improper use

Any other usage not in keeping with the above-mentioned ones may be hazardous and harm persons and/or damage things. Examples of improper use may include, but are not limited to:

- trimming hedges;
- carving operations;
- sectioning pallets, crates and various packing materials;
- sectioning furniture or other materials with nails, screws or other metal components;
- butchering meat;
- using the machine to cut materials other than wood (plastic materials, building materials);
- using the machine to lift, move or split objects;
- using the machine while fastened to fixed supports;
- using cutting means other than those found in the "Technical Data" table. Serious injury and wound hazard.
- using of the machine by more than one person.

**IMPORTANT** *Improper use of the machine will invalidate the warranty, relieve the Manufacturer from all liability, and the user will consequently be liable for all and any damage or injury to himself or others.*

### 3.1.3 User types

This machine is intended for use by consumers, i.e. non-professional operators. It is intended for "DIY" use only.

## 3.2 MAIN COMPONENTS (fig. 1)

- A. Motor:** supplies the drive power to the cutting means.
- B. Control Rod:** hand grip fitted with the main throttle controls.
- C. Rear hand grip:** support hand grip located on the rear of the control rod.

- D. Front hand grip:** support hand grip located on the control rod.
- E. Pruner:** device used for trimming and pruning trees.
- F. Harness:** a fabric belt which, placed over the shoulders, helps support the weight of the machine during work.
- G. Guide bar:** supports and guides the toothed chain.
- H. Toothed chain:** cutting element, consisting of drive links fitted with small blades called "teeth" and side connections held in place by rivets.
- I. Chain restraint element:** safety device that prevents uncontrolled movements of the toothed chain should it break or slacken.
- J. Bar cover guard:** chainsaw cover on the guide bar to be fitted during handling, transportation or storage of the machine.
- K. Battery:** (if non provided with the machine, see chap. 13 "accessories upon request") device that supplies electric current to the tool; its specifications and regulations for use are described in a specific manual.
- L. Battery charger** (if non provided with the machine, see chap. 13 "accessories upon request"): device used to recharge the battery; its specifications and directions for use are described in a specific manual.

## 3.3 IDENTIFICATION LABEL (fig. 1)

The identification label holds the following data:

1. Sound power level
2. Conformity marking
3. Month/Year of manufacture
4. Type of machine
5. Serial number
6. Name and address of Manufacturer
7. Article code
8. Voltage and Frequency of power supply
9. Blade speed

Write the identification data of the machine in the specific space on the label on the back of the cover page.

**IMPORTANT** *Quote the information on the product identification label whenever you contact an authorised service centre.*

**IMPORTANT** *The example of the Declaration of Conformity is provided on the last pages of the manual.*

## 3.4 SAFETY SIGNS (fig. 2)

The machine has various symbols on it.

Meaning of symbols:



**WARNING! DANGER!** The failure to use this machine correctly can be hazardous for oneself and others.  
**PROJECTION HAZARD!** Be careful of flying debris projected by the cutting means, that can cause serious injuries to persons or damage to things.



**WARNING!** Read the instruction manual before using the machine.



Wear protection goggles.



Wear ear protection devices



Wear head protection device



Wear non-slip protective gloves.



Wear non-slip safety footwear..



Do not leave the machine in the rain (or in damp conditions)



**DANGER! Electrocutation.**  
Keep a distance of at least 15 mt from overhead line cables.  
Keep any people or pets at least 15 mt away when using the machine.



Remove the battery before performing any inspections, cleaning or maintenance/ adjustment interventions on the machine:

**IMPORTANT** Any damaged or illegible decals must be replaced. Order replacement decals from an authorised service centre.

#### 4. ASSEMBLY

**⚠ The safety regulations to follow are described in chap. 2. Strictly comply with these instructions to avoid serious risks or dangers.**

For storage and transport purposes, some components of the machine may not be installed in the factory and have to be assembled after unpacking. Follow the instructions below.

**⚠ Unpacking and completing the assembly should be done on a flat and stable surface, with enough space for machine handling and its packaging, always making use of suitable equipment. Do not use the machine until all the instructions provided in the "ASSEMBLY" section have been carried out.**

##### 4.1 UNPACKING

1. Carefully open the packaging, paying attention not to lose components.
2. Consult the documentation in the box, including these instructions.
3. Remove all the unassembled parts from the box.
4. Remove the machine from the box.
5. Dispose of the box and packaging in compliance with local regulations.

##### 4.2 ASSEMBLY OF THE GUIDE BAR AND TOOTHED CHAIN

**⚠ Always wear heavy duty gloves when handling the bar and chain. Mount the bar and chain very carefully so as not to impair the safety and efficiency of the machine. If in doubt, contact your dealer.**

**⚠ Before assembling, make sure the battery is not fitted in its housing.**

1. Remove the knob (Fig. 3.A) and remove the chain guard (Fig. 3.B), to access the drive pinion and bar seat.

2. Mount the bar (Fig. 4.A) by inserting the stud bolt (Fig. 4.B) in the groove (Fig. 4.C) and push it towards the back of the machine body.
3. Mount the chain around the drive pinion (Fig. 5.A) and along the bar guide, being careful to follow the sliding direction (Fig. 5.B).



Direction in which the chain runs

If the tip of the bar is equipped with a nose sprocket, make sure the drive links are correctly inserted in the sprocket rims (Fig. 6).

4. Check that chain tension adjuster pin (Fig. 5.C) is inserted correctly in the hole on the bar; if it isn't, turn the chain tension adjuster screw (Fig. 5.D), until the pin is completely inserted.
5. Replace the guard without fully tightening the knob.
6. Turn the chain tension adjuster screw (Fig. 5.D) to achieve the desired tension (Fig. 7).
7. Raise the bar and tighten the knob (1) securely (Fig. 8.A).

#### 4.2.1 Checking the chain tension

Check the chain tension.

The tension is correct when the drive links do not slip out of the chain guides if you hold the chain in the middle of the bar (Fig. 7)

#### 4.3 ASSEMBLY OF PRUNER DEVICE

**⚠ Before assembling, make sure the battery is not fitted in its housing.**

1. Insert the pruner device (Fig. 9.A) in the control rod (Fig. 9.B) until the stop pins (Fig. 9.C) click into the hole (Fig.9.D) in the rod. Insertion is completed when the stop pins protrude completely from the hole.
2. Close the clamping lever (Fig. 9.A).

**⚠ Periodically check that the joints are well tightened.**

#### 4.4 EXTENSION OF THE PRUNER DEVICE

1. Open the clamping lever (Fig. 10.A).
2. Pull or push the rod (Fig. 10.B) until it reaches the desired length.
3. Close the clamping lever (Fig. 10.A).

**⚠ Periodically check that the joints are well tightened.**

#### 4.5 REMOVING THE PRUNER DEVICE

**⚠ Wait until the motor is sufficiently cold before removing the pruner device.**

To remove the pruner device (Fig. 9.A):

1. Place the control rod (Fig. 9.B) on the ground.
2. Open the clamping lever (Fig. 9.E).
3. Push on the stop pin (Fig. 9.C) and remove it from the hole (Fig. 9.D).
4. Disassemble the pruner device.

### 5. CONTROLS

#### 5.1 THROTTLE TRIGGER LEVER

The throttle trigger lever (Fig. 11.A) allows the activation of the cutting means.

The activation of the throttle trigger lever (Fig. 11.A) is only possible if the throttle lock button is pressed (Fig. 11.B).

#### 5.2 THROTTLE LOCK BUTTON

The throttle lock button (Fig. 11.B) allows the throttle trigger lever to be used (Fig. 11.A).

### 6. USING THE MACHINE

**⚠ The safety regulations to follow are described in chap. 2. Strictly comply with these instructions to avoid serious risks or dangers.**

#### 6.1 PRELIMINARY PROCEDURES

Place the machine in a stable horizontal position on the ground.

##### 6.1.1 Checking and recharging the battery (Fig. 12)

Before each use check the battery charge status according to the instructions in the battery booklet.

##### 6.1.2 Using the harness

**⚠ Frequently check the efficiency of the quick release in order to free the machine quickly from the belts in the event of danger.**

The harness must be put on before connecting the machine to the special



coupling and the belt must be adjusted to suit the operator's height and build.

1. The belt (Fig. 13.A) must go from the left shoulder to the right hip.
2. Hook the carabiner (Fig. 13.B) to the special coupling located on the control rod.
3. If necessary, release the clip buckle (Fig. 13.C) to remove the machine from the harness.

### 6.1.3 Filling with chain lubrication oil

Fill with chain lubrication oil before using the machine. For oil filling methods and precautions (see paragraph 7.3).

### 6.1.4 Checking the chain tension

**⚠ This operation must be done with the machine off and the battery removed from its housing (par. 7.2.2).**

Check the chain tension.

The tension is correct when the drive links do not slip out of the chain guides if you hold the chain in the middle of the bar (Fig. 7).

To adjust the chain tension:

1. Loosen the guard knob (Fig. 3.A).
2. Turn the chain tension adjuster screw (Fig. 5.D) to achieve the desired tension;
3. Raise the bar and tighten the knob securely. (Fig. 8.A).

**⚠ Never work with the chain loose, as it can be hazardous if the chain slips out of the bar guides.**

**IMPORTANT** During the first period of use (or after replacing the chain) it must be checked more frequently due to settling of the chain.

## 6.2 SAFETY CHECKS

**⚠ Always carry out the safety checks before use.**

### 6.2.1 General safety check

Object	Result
Grip and guards	Clean, dry and fixed firmly to the machine.
Screws on the machine and blade	Correctly tightened (not loose)
Cooling air ducts	Not clogged
Guide rod	Properly installed

Chain	Sharp, not damaged or worn, mounted and tensioned correctly.
Guards	Intact, undamaged.
Battery	No damage to the casing, no liquid leakage
Machine	No signs of damage or wear. No abnormal vibrations. No abnormal sound.
Throttle trigger lever, Throttle lock button	They must move freely, not be forced and when released they must return automatically and rapidly to the neutral position.

### 6.2.2 Machine operating test

Action	Result
Fit the battery inside its housing (par. 7.2.3).	The chain should not move
Activate the throttle trigger lever. (without pressing the throttle lock button)	The throttle trigger lever remains blocked.
Press the throttle lock button and throttle trigger lever.	The levers must move freely and not be forced. The chain moves.
Release the throttle trigger lever.	The lever automatically and rapidly returns to the idle position. The chain should stop.

**⚠ If any of the results fail to match the instructions provided in the tables, do not use the machine! Contact a service centre to have it checked and repaired if necessary.**

## 6.3 START-UP

1. Remove the protection bar cover (Fig. 1.J).
2. Make sure the bar and the chain are not touching the ground or any other object.
3. Fit the battery (Fig. 14.A) inside its housing pressing down until you hear it clicks firmly into position and assure the electrical contact.
4. Activate the throttle lock button (Fig. 11.B) and the throttle trigger lever (Fig. 11.A).

## 6.4 WORKING

Before delimiting for the first time, make sure:

- To have been specifically trained to use this type of equipment.
- To wear the harness correctly.
- To have carefully read the safety regulations and user instructions contained in this manual.
- You practise first on logs on the ground or attached to trestles, in order to get familiar with the machine and the most suitable cutting techniques.

To use the machine proceed as follows:

1. always keep the machine connected to the correctly worn harness when working (see paragraph 6.1.2).
2. The machine must always be firmly held in both hands .

**⚠ Stop the machine immediately if the chain stops during sawing.**

**NOTE** *During use, the battery is protected against total drainage with a protective device that switches off the machine and stops it from working.*

#### 6.4.1 Checks to be conducted whilst working

##### 6.4.1.a Checking the chain tension

The chain tends to stretch gradually as you work, so you need to check its tension frequently (par. 6.1.4).

##### 6.4.1.b Checking the oil delivery

**IMPORTANT** *Never use the machine without lubrication!*

**⚠ Make sure the bar and the chain are in place when you check the oil delivery.**

Start the motor (par. 6.3) and check if the chain oil is delivered as shown in (fig. 15).

#### 6.4.2 Work techniques

##### 6.4.2.a Delimiting a tree

**⚠ Make sure there is nothing or nobody in the area where the branches will fall.**

1. Stand opposite the branch you want to cut.
2. Start cutting lower branches followed by the higher ones.

3. Make first cut from the bottom towards the top (Fig. 16.A). Complete delimiting by cutting from top to bottom, as shown in (Fig. 16.B).

#### 6.4.2.b Limbing tree branches

Limbing means removing the branches from a felled tree.

**⚠ Be careful of where the branches are lying on the ground, the risk of them being under tension, the direction the branch may go during cutting and the risk of the tree being unstable after the branch has been cut.**

When limbing, it is necessary to leave the lower, larger branches to support the trunk on the ground. Remove the small branches with a single cut (Fig. 17.A).

It is recommended to cut the tensioned branches working from the bottom upwards to prevent the chainsaw from bending (Fig. 17.B).

### 6.5 ADVICE FOR OPERATION

**IMPORTANT** *Stop the machine (par. 6.6) when moving between work areas.*

If the machine should get stuck during pruning high up, the operator must:

1. Release the throttle trigger lever immediately (Fig. 11.A).
2. Wait for the cutting means to come to a halt.
3. Remove the battery (par. 7.2.2).
4. Pull the pruner out from the cut, lifting the branch where necessary.
5. If necessary, use a handsaw or second chainsaw to free the trapped pruner, cutting at a minimum distance of 30 cm from the trapped pruner. Cutting operations to free the pruner must always be performed towards the end of the branch, (i.e. between the trapped pruner and the end of the branch and not between the trunk and the trapped pruner). This will prevent the pruner from being dragged by the part of the branch that is cut away, which would complicate the situation even further.

### 6.6 STOP

To stop the machine release the throttle trigger lever (Fig. 11.A).

**⚠ After releasing the throttle trigger lever it takes a few seconds for the toothed chain to stop.**

Always stop the machine when moving between work areas.

**⚠ Do not keep your finger on the throttle lock button when moving the machine to avoid accidentally enabling the machine.**

## 6.7 AFTER USE

1. Remove the battery from its housing and recharge it (par. 7.2.2).
2. Mount the bar cover.
3. Allow the motor to cool before storing in an enclosed space.
4. Loosen the rod fastening knob to reduce chain tension.
5. Carefully remove any dust and debris and remove all traces of sawdust or oil deposits from the chain (par. 7.4.2).
6. Check there are no loose or damaged components. If necessary, replace the damaged components and tighten any screws and loose bolts.
7. Check there are no damages to the machine. If necessary contact the authorised service centre.

**IMPORTANT** Always remove the battery (par. 7.2.2) and fit the blade guard whenever the machine is unused or left unattended.

## 7. MAINTENANCE

### 7.1 GENERAL INFORMATION

**⚠ The safety regulations to follow are described in chap. 2. Strictly comply with these instructions to avoid serious risks or dangers.**

**⚠ Before conducting any inspections, cleaning or maintenance/adjustment interventions on the machine:**

- Stop the machine
- Wait until the chain is stationary
- Remove the battery from its housing and recharge it (para. 7.2.2) (never leave the battery inserted or within the reach of children or unauthorised persons)
- Apply the bar cover, except when working directly on the chain or bar itself
- Wait until the motor is sufficiently cold
- Read the relevant instructions
- Use suitable clothing, protective gloves and goggles.

**IMPORTANT** Any maintenance and adjustment operations not described in

this manual must be carried out by your dealer or Authorised Service Centre.

### 7.2 BATTERY

#### 7.2.1 Battery power reserve

Battery autonomy is mainly influenced by:

- a. environmental factors, that cause higher energy requirements:
  - cutting trees and branches that are too thick;
- b. operator behaviour that should be avoided:
  - switching the machine on and off frequently whilst working;
  - adopting a cutting technique that is unsuitable for the work to be performed (par. 6.4.2);

To optimise battery power reserve it is always recommended to:

- cut wood when dry;
- use the most appropriate technique for the work to be performed

If the need arises to use the machine for sessions which exceed the capability of a standard battery, it is possible to:

- purchase a second standard battery to immediately replace the discharged battery, without compromising the continuity of operations;

#### 7.2.2 Battery removal and recharging (Fig.18÷21)

Fully charge the battery according to the instructions in the battery/battery charger booklet.

**NOTE** The battery is equipped with a guard that inhibits recharging if the environmental temperature is not between 0 and +45 °C.

**NOTE** The battery can be recharged at any time, even partially, with no risk of damaging it.

### 7.3 TOPPING UP THE CHAIN OIL TANK

**IMPORTANT** Only use chainsaw oil or adhesive oil for chainsaws. Do not use oil containing impurities so as not to block the oil filter and to prevent irreparable damage to the oil pump. It is essential that you use good quality oil to lubricate the cutting parts effectively. Used or poor quality oil does not guarantee good lubrication and reduces the working life of the chain and bar.

**IMPORTANT** *Never run the chain without sufficient oil, this could damage the Pruner device and compromise safety.*

If the oil level is low, top up as follows:

1. Unscrew and remove the cap (Fig. 22.A) from the oil tank.
2. Pour oil in the tank and monitor the level on the indicator (Fig. 22.B).
3. Make sure no impurities penetrate the oil tank when filling.
4. Screw on the oil cap and tighten it.

## 7.4 CLEANING

### 7.4.1 Cleaning the machine and the motor

After every work session:

- Clean the machine thoroughly to remove all dust and debris.
- To reduce fire hazards, keep the machine and, in particular, the motor free of leaves, branches or excessive grease.
- Always clean the machine after use with a damp cloth dipped in neutral detergent.
- Remove all traces of humidity using a soft damp cloth. Humidity can generate risks of electric shocks.
- Do not use aggressive detergents or solvents to clean the plastic parts or hand grips.
- Do not spray water onto the motor and electrical components and prevent them from getting wet.
- To avoid overheating and damage to the motor or the battery, always keep the cooling air vents clean and free of debris.

### 7.4.2 Cleaning the chain

Remove any traces of sawdust or oil deposits from the chain every time it is used.

If there is excessive dirt or resin build-up:

1. Disassemble the chain and place it in a container with a specific cleanser for a few hours.
2. Rinse it with clean water and treat it with a suitable anticorrosive spray
3. Reassembling on the machine.

## 7.5 CHAIN CATCHER

Check the chain catcher conditions before each use (Fig. 1.I) and repair in the event of damages.

## 7.6 MACHINE AND BAR LUBRICATION HOLES

Before daily use,:

1. Remove the guard (par. 4.2)
2. Disassemble the bar
3. Check that machine lubrication holes (Fig. 23.A) and guide bar (Fig. 23.B) are not clogged.

## 7.7 NUTS AND BOLTS

- Keep all nuts, bolts and screws tight to be sure the equipment is in safe working condition.
- Check regularly that the handles are fixed firmly.

## 7.8 CHAIN DRIVE SPROCKET

Once a month check the condition of the sprocket with your local dealer and replace it when wear exceeds the accepted limits.

 ***Do not mount a new chain with a worn sprocket or vice-versa.***

## 7.9 MAINTENANCE OF THE TOOTHED CHAIN

 ***To ensure that the chainsaw works safely and efficiently, it is essential that the cutting means are well-sharpened.***

Chain sharpening is necessary when:

- The sawdust looks like dust.
- Cutting becomes more difficult.
- The cut is not straight.
- Vibrations increase.

 ***Kickback may occur if the chain is not sufficiently sharpened***

**IMPORTANT** *It is recommended to have an Authorised centre sharpen the chain using the right tools to ensure minimum removal of material and even sharpness on all the cutting edges.*

### 7.9.1 Replacing the toothed chain

Replace the chain whenever:

- the length of the cutting edges reduces to 5 mm or less;
- there is too much play between the links and the rivets.
- the cutting speed is too slow and the repeated sharpening does not improve the cutting speed. The chain is worn.

**IMPORTANT** After replacing the chain, its tension level must be checked more frequently due to settling of the chain.

## 7.10 GUIDE BAR MAINTENANCE

**NOTE** Any work on the guide bar requires specific experience and special tools in order to achieve top workmanship standards; for safety purposes, we recommend you contact your dealer to ensure work is done correctly.

To avoid asymmetrical wear on the bar, make sure it is turned over periodically.

To keep the bar in perfect working order, proceed as follows:

1. Grease the bearings on the nose sprocket (if present) with the syringe (not included).
2. Clean the bar groove with the scraper (not included) (Fig. 24.A).
3. Clean the lubrication holes (Fig. 24.B).
4. With a flat file, remove burr from the edges and level off the guides.

### 7.10.1 Replacing the bar

Replace the bar whenever:

- The groove is not as deep as the height of the drive links (which must never touch the bottom).
- The inside of the guide is worn enough to make the chain lean to one side.

## 8. STORING

**IMPORTANT** The safety regulations to follow for putting into storage are described in paragraph 2.4. Strictly comply with these instructions to avoid serious risks or dangers.

### 8.1 STORING THE MACHINE

When the machine is to be stored away:

1. Remove the battery from its housing and recharge it (par. 7.2.2).
2. When the cutting means has halted, mount the bar cover.
3. Allow the motor to cool before storing in an enclosed space.
4. Clean (par. 7.4).
5. Check there are no loose or damaged components. If necessary, replace the damaged components and tighten any screws and loose bolts or contact the authorised service centre.
6. Store the machine:
  - in a dry place
  - protected from inclement weather

- in a place where children cannot get to it
- making sure that keys or tools used for maintenance are removed.

### 8.2 STORING THE BATTERY

If the battery is not charged for a long period of time, it must be kept in a cool, shaded place without humidity, with environmental temperature between 0~45°C.

**NOTE** If unused for any length of time, recharge the battery every two months to prolong its working life.

## 9. HANDLING AND TRANSPORTATION

Whenever the machine is to be handled, raised, transported or tilted you must:

1. Stop the machine
2. Wait until the chain is stationary
3. Remove the battery from its housing and recharge it
4. Mount the bar cover
5. Wait until the motor is sufficiently cold
6. Wear heavy work gloves
7. Only hold the machine using the hand grips and position the bar in the opposite direction to that used during operation

When transporting the machine on a vehicle, always:

1. Fasten the machine securely with cables or chains
2. Position it so that it does not cause a hazard to anyone.

## 10. ASSISTANCE AND REPAIRS

This manual provides all the necessary information to run the machine and for correct basic maintenance operations which can be performed by the user. Any regulations and maintenance operations not described herein must be carried out by your Dealer or Authorised Service Centre. Any operations performed in unauthorised centres or by unqualified persons will totally invalidate the Warranty and all obligations and responsibilities of the Manufacturer.

- Non-original parts and attachments are not approved; use of non-original spare parts and attachments will jeopardise the safety of the machine and relieve the Manufacturer from all obligations or liabilities.
- Original spare parts are supplied by authorised Dealers and by Authorised Service Centres.

## 11. WARRANTY

## COVERAGE

The warranty conditions are intended for consumers only, i.e. non-professional operators.

The warranty covers all material quality and manufacturing defects recognised during the warranty period by your Dealer or Authorised Service Centre.

The warranty is restricted to the repair or replacement of components recognised as faulty.

The warranty only applies to machines subjected to regular maintenance.

The warranty does not cover damages resulting from:

- Failure to become familiar with the documentation accompanying the machine (Instruction manuals).
- Professional use.
- Carelessness, negligence.
- External causes (lightning, impact, presence of foreign bodies inside the machine) or incidents.
- Incorrect use or assembly are prohibited by the manufacturer.
- Poor maintenance.
- Modification to the machine.

- Use of non-genuine spare parts (adaptable parts).
- Use of accessories not supplied or approved by the manufacturer.

The warranty does not cover:

- The maintenance operations (described in the instruction manual).
- Normal wear and tear of consumables.
- Normal wear and tear.
- Deterioration in the appearance of the machine due to use.
- Any ancillary expenses related to the enforcement of the warranty, such as costs incurred to travel to the user's location, transfer of the machine to the Dealer, rental of replacement equipment or calling of independent enterprises to perform maintenance work.

The user is protected by his or her own national legislation. The user's rights under the national laws or his or her own country are not in any way restricted by this warranty.

## 12. TROUBLESHOOTING

PROBLEM	PROBABLE CAUSE	SOLUTION
1. Throttle trigger lever and throttle lock button are operated but the machine does not start.	Battery is not inserted or is inserted incorrectly	Make sure that the battery is inserted correctly (Fig. 14.A)
	Low battery	Check the battery status and recharge if necessary (par. 7.2.2)
	Machine damaged	Do not use the machine Remove the battery and Contact a Service Centre.
2. The motor shuts down whilst working	Battery is not inserted correctly	Make sure that the battery is inserted correctly (Fig. 14.A)
	Low battery	Check the battery status and recharge if necessary (par. 7.2.2)
	Machine damaged	Do not use the machine. Remove the battery and Contact an Authorised Service Centre.

3. With the throttle lock button and throttle trigger lever on, the chain does not turn	Excessive chain tensioning	Retension the chain (par. 6.1.4).
	Bar and chain problems	Check that the chain runs freely and the bar guides are not deformed (par. 7.10).
	Machine damaged.	Do not use the machine. Immediately turn off the machine remove the battery and Contact an Authorised Service Centre.
4. The chain heats and emits smoke on the end part of the bar.	Excessive chain tensioning	Retension the chain (par. 6.1.4).
	Lubricant oil tank empty.	Fill the lubricant oil tank (par. 7.3).
5. The motor runs irregularly and lacks power when revved	Bar and chain problems	Check that the chain runs freely and the bar guides are not deformed (par. 7.10).
6. Excessive noise and/or vibration is experienced whilst working	Loose or damaged parts	Turn off the machine, remove the battery and: <ul style="list-style-type: none"> <li>– inspect for damage;</li> <li>– check for and tighten any loose parts;</li> <li>– Contact an Authorised Service Centre for replacement or repair damaged parts with parts having equivalent specifications.</li> </ul>
7. Battery power reserve is low	Severe working conditions requiring greater current absorption	Optimise operations (par. 7.2.1)
	Battery is insufficient for operating requirements	Use a second battery or extended battery (par. 7.2.1)
	Decrease in battery capacity	Purchase a new battery
8. The battery charger is not recharging the battery	Battery is not correctly inserted in the battery charger	Check it is correctly inserted (par. 7.2.2)
	Unsuitable environmental conditions	Recharge the battery in places with suitable temperatures (see battery/battery charger instruction manual)
	Dirty contacts	Clean the contacts
	The battery charger is not energised	Check it is plugged in and the power socket is energised
	Faulty battery charger	Replace with an original spare part
		If the problem persists, refer to the battery/ battery charger manual

If problems persist after having performed the above operations, contact your dealer.

## 13. ATTACHMENTS ON REQUEST

### 13.1 BATTERY

Different capacity batteries are available to suit specific operating requirements (Fig. 25). The list of approved batteries for this machine is found in the "Technical Data" table.

### 13.2 BATTERY CHARGER

Device used to recharge the battery (Fig. 26).

### 13.3 BARS AND CHAINS

The "Correct bar and chain combination table" contains a list of all possible combinations between bar and chain, indicating those which may be used on each machine, marked with the symbol "✓". The same table also provides the specification data for all chains and bars approved for use on each machine.

** Only use the replacement bars and chains listed in the table. The use of unapproved combinations may be hazardous and cause serious injuries to operators and damage the machine.**

** In consideration that the selection, application and use of the bar and chain are actions made solely by the user, at his own discretion, the latter assumes responsibility for damages of any kind arising from such actions. When in doubt or if lacking knowledge of the specifics of each bar or chain, contact your dealer or an authorised garden centre.**



**DICHIARAZIONE CE DI CONFORMITÀ (Istruzioni Originali)**  
(Direttiva Macchine 2006/42/CE, Allegato II, parte A)

1. La Società: ST. S.p.A. – Via del Lavoro, 6 – 31033 Castelfranco Veneto (TV) – Italy

2. Dichiara sotto la propria responsabilità, che la macchina:

Potatrice ad Asta alimentata a batteria (abbattimento, sezionamento, sramatura di alberi)

a) Tipo / Modello Base:	MP 20 Li S, MP 20 Li A
c) Numero di Serie:	22A••CHA000001 ÷ 99L••CHA999999
d) Motore:	a batteria

3. È conforme alle specifiche delle direttive:

• MD: 2006/42/EC

e) Ente Certificatore: N. 0905 – Intertek Deutschland GmbH  
Stangenstrasse 1, 70771 Leinfelden-Echterdingen - Germany

f) Esame CE del tipo: 20SHW1609-01

• OND: 2000/14/EC, ANNEX V - 2005/88/EC

• EMCD: 2014/30/EU

• RoHS II: 2011/65/EU - 2015/863/EU

4. Riferimento alle Norme armonizzate:

EN 62841-1:2015 + AC:2015

EN ISO 11680-1:2011

EN IEC 55014-1:2021

EN IEC 55014-2:2021

EN IEC 63000:2018

g) Livello di potenza sonora misurato: 85,4 dB(A)

h) Livello di potenza sonora garantito: 87 dB(A)

j) Potenza installata: /

n) Persona autorizzata a costituire il FascicoloTecnico: ST. S.p.A.  
Via del Lavoro, 6  
31033 Castelfranco Veneto (TV) - Italia

o) Castelfranco Veneto, 01/10/2022

CEO Stiga Group

Sean Robinson

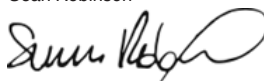

## UK DECLARATION OF CONFORMITY

(Supply of Machinery (Safety) Regulations 2008, S.I. 2008 No. 1597, Annex II, part A)

1. The company: ST. S.p.A. – Via del Lavoro, 6 – 31033 Castelfranco Veneto (TV) – Italy

2. Hereby declares under its own responsibility that the machine (function):

Battery powered pole-mounted pruner (felling, bucking, delimiting trees)

a) Homologation type:	MP 20 Li S, MP 20 Li A
c) Serial number:	22A••CHA000001 ÷ 99L••CHA999999
d) Engine:	battery-operated

3. Conforms to UK Regulations:

• S.I. 2008/1597 - Supply of Machinery (Safety) Regulations 2008

e) Notified body: N. 0905 – Intertek Deutschland GmbH  
Stangenstrasse 1, 70771 Leinfelden-Echterdingen - Germany

f) EC type-examination: 20SHW1609-01

- S.I. 2001/1701 - Schedule 8 - Noise Emission in the Environment by Equipment for use Outdoors Regulations 2001
- S.I. 2016/1091 - Electromagnetic Compatibility Regulations 2016
- S.I. 2012/3032 - The Restriction of the Use of Certain Hazardous Substances in Electrical and Electronic Equipment Regulations 2012

4. Reference to harmonised standards:

EN 62841-1:2015 + AC:2015  
EN ISO 11680-1:2011  
EN IEC 55014-1:2021  
EN IEC 55014-2:2021  
EN IEC 63000:2018

g) Measured sound power level: 85,4 dB(A)

h) Guaranteed sound power level: 87 dB(A)

j) Net power installed: /

n) Person authorised to compile the technical file: ST. S.p.A.  
Via del Lavoro, 6  
31033 Castelfranco Veneto (TV) - Italia

o) Castelfranco Veneto, 01/10/2022  
CEO Stiga Group  
Sean Robinson



UK Importer: STIGA LTD  
Unit 8, Bluewater Estate Plympton,  
Devon, PL7 4JH, England



<p><b>FR (Traduction de la notice originale)</b></p> <p>Déclaration CE de Conformité (Directive Machines 2006/42/CE, Annexe II, partie A)</p> <p>1. La Société</p> <p>2. Déclare sous sa propre responsabilité que la machine : Scie à chaîne alimentée par batterie portable, abattage/tronçonnage/ébranchage d'arbres</p> <p>a) Type / Modèle de Base c) Série d) Moteur: batterie</p> <p>3. Est conforme aux prescriptions des directives : e) Organisme de certification f) Examen CE du Type</p> <p>4. Renvoi aux Normes harmonisées g) Niveau de puissance sonore mesuré h) Niveau de puissance sonore garanti k) Puissance installée n) Personne habilitée à établir le Dossier Technique : o) Lieu et Date</p>	<p><b>EN (Translation of the original instruction)</b></p> <p>EC Declaration of Conformity (Machine Directive 2006/42/EC, Annex II, part A)</p> <p>1. The Company</p> <p>2. Herby declares under its own responsibility that the machine: Portable battery powered chainsaw, Felling/bucking/delimiting trees</p> <p>a) Type / Base Model c) Serial number d) Motor: battery-operated</p> <p>3. Conforms to directive specifications: e) Certifying body f) EC examination of Type</p> <p>4. Reference to harmonised Standards g) Sound power level measured h) Sound power level guaranteed k) Power installed n) Person authorised to create the Technical Folder: o) Place and Date</p>	<p><b>DE (Übersetzung der Originalbetriebsanleitung)</b></p> <p>EG-Konformitätserklärung (Maschinenrichtlinie 2006/42/EG, Anhang II, Teil A)</p> <p>1. Die Gesellschaft</p> <p>2. Erklärt auf eigene Verantwortung, dass die Maschine: Tragbare batteriebetriebene Kettensäge, fällen/schneiden/entasten von Bäumen</p> <p>a) Typ / Basismodell c) Seriennummer d) Motor: Batterie</p> <p>3. Den Anforderungen der folgenden Richtlinien entspricht: e) Zertifizierungsstelle f) EG-Baumusterprüfung</p> <p>4. Bezugnahme auf die harmonisierten Normen g) Gemessener Schalleistungspegel h) Garantierter Schalleistungspegel k) Installierte Leistung n) Zur Verfassung der technischen Unterlagen befugte Person: o) Ort und Datum</p>
<p><b>NL (Vertaling van de oorspronkelijke gebruiksaanwijzing)</b></p> <p>EG-verklaring van overeenstemming (Richtlijn Machines 2006/42/CE, Bijlage II, deel A)</p> <p>1. Het bedrijf</p> <p>2. Verklaart onder zijn eigen verantwoordelijkheid dat de machine: Kettingzaag met accuvoeding, vellen/snijden/snoeien van bomen</p> <p>a) Type / Basismodel c) Serienummer d) Motor: accu</p> <p>3. Voldoet aan de specificaties van de richtlijnen: e) Certificatie-instituut f) EG-onderzoek van het Type</p> <p>4. Verwijzing naar de Geharmoniseerde normen g) Gemeten niveau van geluidsvermogen h) Gearandeerd niveau van geluidsvermogen k) Geïnstalleerd vermogen n) Bevoegd persoon voor het opstellen van het Technisch Dossier o) Plaats en Datum</p>	<p><b>ES (Traducción del Manual Original)</b></p> <p>Declaración de Conformidad CE (Directiva Máquinas 2006/42/CE, Anexo II, parte A)</p> <p>1. La Empresa</p> <p>2. Declara bajo su propia responsabilidad que la máquina: Motosierra de cadena alimentada por batería portátil, tala/seccionamiento/poda de árboles</p> <p>a) Tipo / Modelo Base c) Matricula d) Motor: batería</p> <p>3. Cumple con las especificaciones de las directivas: e) Ente certificador f) Examen CE del Tipo</p> <p>4. Referencia a las Normas armonizadas g) Nivel de potencia sonora medido h) Nivel de potencia sonora garantizado k) Potencia instalada n) Persona autorizada a realizar el Manual Técnico: o) Lugar y Fecha</p>	<p><b>PT (Tradução do manual original)</b></p> <p>Declaração CE de Conformidade (Diretiva de Máquinas 2006/42/CE, Anexo II, parte A)</p> <p>1. A Empresa</p> <p>2. Declara sob a própria responsabilidade que a máquina: Motosserra alimentada por bateria portátil, abate/seccionamento/desramação</p> <p>a) Tipo / Modelo Base c) Matrícula d) Moto: Bateria</p> <p>3. É conforme às especificações das diretivas: e) Órgão certificador f) Exame CE do Tipo</p> <p>4. Referência às Normas harmonizadas g) Nível medido de potência sonora h) Nível garantido de potência sonora k) Potência instalada n) Pessoa autorizada a elaborar o Caderno Técnico o) Local e Data</p>
<p><b>EL (Μετάφραση του πρωτοτύπου των οδηγιών χρήσης)</b></p> <p>ΕΚ-Δήλωση συμμόρφωσης (Οδηγία Μηχανών 2006/42/CE, Παράρτημα II, μέρος Α)</p> <p>1. Η Εταιρία</p> <p>2. Δηλώνει υπεύθυνα ότι η μηχανή: Φορητό αλυσσπρίονο μπαταρίας, Κατάρριψη/κατασμή/κοπή κλαδιών δέντρων</p> <p>a) Τύπος / Βασικό Μοντέλο c) Αριθμός μητρώου d) Κινητήρας: μπαταρία</p> <p>3. Συμμορφώνεται με τις προδιαγραφές της οδηγίας: e) Οργανισμός πιστοποίησης f) Εξέταση CE του Τύπου</p> <p>4. Αναφορά στους Κανονισμούς εναρμόνισης g) Στάθμη μέτρησης ακουστικής ισχύος h) Στάθμη εγγυημένης ακουστικής ισχύος k) Εγκυατοσημένη ισχύς n) Εξουσιοδοτημένο άτομο για την κατάρτιση του Τεχνικού Φυλλαδίου: o) Τόπος και Χρόνος</p>	<p><b>TR (Orjinal Talimatların Tercümesi)</b></p> <p>AT Uygunluk Beyanı (2006/42/CE Makine Direktifi, Ek II, bölüm A)</p> <p>1. Şirket</p> <p>2. Şahsi sorumluluğunda aşağıdaki makinenin: Batarya beslemeli taşınabilir zincirli testere, Ağaçların kesilip devrilmesi/parçalara bölünmesi/dallarının budanması</p> <p>a) Tip / Standart model c) Sicil numarası d) Motor: batarya</p> <p>3. Aşağıdaki direktiflerin özelliklerine uygun olduğunu beyan etmektedir: e) Sertifikalandırın kurum f) ... Tipi CE incelemesi</p> <p>4. Harmonize standartlara atf g) Ölçülen ses gücü seviyesi h) Garant edilmiş ses gücü seviyesi k) Kurulu güç n) Teknik Dosyayı oluşturmaya yetkili kişi: o) Yer ve Tarih</p>	<p><b>МК (Превод на оригиналните упатства)</b></p> <p>Декларација за усогласеност со ЕУ (Директива за машини 2006/42/CE, Анекс II, дел А)</p> <p>1. Компанијата</p> <p>2. изјавува со целосна лична одговорност дека следната машина: моторна пила на батерија, Соборување/сечење/кастреве на дрва</p> <p>a) Тип / основен модел производство в) етикета г) мотор: акумулатор</p> <p>3. Усогласено со спецификациите според директивите: д) тело за сертификација f) тест CE за типот</p> <p>4. Референци за усогласени нормативи e) Акустички притисок ж) измерено ниво на звучна моќност з) обем на сечење н) овластено лице за составување на Техничката брошура o) место и датум</p>

<p><b>NO (Oversættelse av original bruksanvisning)</b></p> <p>EF- Samsvarserklæring (Maskindirektiv 2006/42/EF, Vedlegg II, del A)</p> <ol style="list-style-type: none"> <li>1. Firmaet</li> <li>2. Erklærer på eget ansvar at maskinen: Bærbar batteridrevet kjedesag, nedfelling/kutt/kvisting av trær</li> <li>a) Type / Modell</li> <li>c) Serienummer</li> <li>d) Motor: batteri</li> <li>3. Oppfyller kravene i direktivene:</li> <li>e) Sertifiseringsorgan</li> <li>f) EF-typeprøving</li> <li>4. Henvisning til harmoniserte standarder</li> <li>g) Målt lydeffektivité</li> <li>h) Garantert lydeffektivité</li> <li>k) Installert effekt</li> <li>n) Person som har fullmakt til å utferdige teknisk dokumentasjon:</li> <li>o) Sted og dato</li> </ol>	<p><b>SV (Översättning av bruksanvisning i original)</b></p> <p>EG-försäkringen om överensstämmelse (Maskindirektiv 2006/42/EG, bilaga II, de la)</p> <ol style="list-style-type: none"> <li>1. Företaget</li> <li>2. Försäkrar på eget ansvar att maskinen Batteridrivnen bärbär kjedesåg, fällning/kapning/gränklippning av träd</li> <li>a) Typ / Basmodell</li> <li>c) Serienummer</li> <li>d) Motor: batteri</li> <li>3. Överensstämmer med föreskrifterna i direktivet</li> <li>e) Intygsorgan _ Anmält organ</li> <li>f) EG typgodkännande</li> <li>4. Referens till harmoniserade standarder</li> <li>g) Uppmått ljudeffektivité</li> <li>h) Garanterad ljudeffektivité</li> <li>k) Installerad effekt</li> <li>n) Auktoriserad person för upprättandet av den tekniska dokumentationen:</li> <li>o) Ort och datum</li> </ol>	<p><b>DA (Oversættelse af den originale brugsanvisning)</b></p> <p>EF-øverensstemmelseserklæring (Maskindirektiv 2006/42/EF, bilag II, del A)</p> <ol style="list-style-type: none"> <li>1. Firmaet</li> <li>2. Erklærer på eget ansvar, at maskinen: Bærbar batteridreven kædesav, fældning af træer/udskæring af stykker/opskæring af grene</li> <li>a) Type / Model</li> <li>c) Serienummer</li> <li>d) Motor: batteri</li> <li>3. Er i overensstemmelse med specifikationerne ifølge direktiverne:</li> <li>e) Certificeringsorgan</li> <li>f) EF-typeafprøvning</li> <li>4. Henvisning til harmoniserede standarder</li> <li>g) Målt lydeffektivité</li> <li>h) Garanteret lydeffektivité</li> <li>k) Installeret effekt</li> <li>n) Person, der har bemyndigelse til at udarbejde det tekniske dossier:</li> <li>o) Sted og dato</li> </ol>
<p><b>FI (Alkuperäisten ohjeiden käännö)</b></p> <p>EY-VAATIMUSTENMUKAISUUSVAKUUTUS (Konedirektiivi 2006/42/EY, Liite II, osa A)</p> <ol style="list-style-type: none"> <li>1. Yritys</li> <li>2. Vakuuttaa omalla vastuullaan, että kone: Käsin kannateltava akkukäyttöinen moottorisaha, Puiden kaataminen/piikkominen/karsinta</li> <li>a) Tyyppi / Perusmalli</li> <li>c) Sarjanumero</li> <li>d) Moottori : akku</li> <li>3. On yhdenmukainen seuraavien direktiivien asettamien vaatimusten kanssa:</li> <li>e) Sertifointiyritys</li> <li>f) EY-tyypitarkastus</li> <li>4. Viittaus harmonisoiituihin standardeihin</li> <li>g) Mitattu äänitehotaso</li> <li>h) Taattu äänitehotaso</li> <li>k) Asemettu teho</li> <li>n) Teknisten asiakirjojen laatimiseen valtuutettu henkilö:</li> <li>o) Paikka ja päivämäärä</li> </ol>	<p><b>CS (Překlad původního návodu k používání)</b></p> <p>ES – Prohlášení o shodě (Směrnice o Strojních zařízeních 2006/42/ES, Příloha II, část A)</p> <ol style="list-style-type: none"> <li>1. Společnost</li> <li>2. Prohlašuje na vlastní odpovědnost, že stroj: Přenosná akumulátorová řetězová motorová pila Kácení/rozřezávání/odvětvování stromů</li> <li>a) Typ / Základní model</li> <li>c) Výrobní číslo</li> <li>d) Motor: akumulátor</li> <li>3. Je ve shodě s nařízenímí směrnice:</li> <li>e) Certifikační orgán</li> <li>f) ES zkouška Typu</li> <li>4. Odkazy na Harmonizované normy</li> <li>g) Naměřená úroveň akustického výkonu</li> <li>h) Zaručená úroveň akustického výkonu</li> <li>k) Instalovaný výkon</li> <li>n) Osoba autorizovaná pro vytvoření Technického spisu:</li> <li>o) Místo a Datum</li> </ol>	<p><b>PL (Tłumaczenie instrukcji oryginalnej)</b></p> <p>Deklaracja zgodności WE (Dyrektywa maszynowa 2006/42/WE, Załącznik II, część A)</p> <ol style="list-style-type: none"> <li>1. Spółka</li> <li>2. Oświadczam na własną odpowiedzialność, że maszyna: Przenośna pilarka łańcuchowa z zasilaniem akumulatorem, Ścinanie, obalanie/przerzwanie/okrzesywanie drzew</li> <li>a) Typ / Model podstawowy</li> <li>c) Numer seryjny</li> <li>d) Silnik: akumulator</li> <li>3. Spełnia podstawowe wymogi następujących Dyrektyw:</li> <li>e) Jednostka certyfikująca</li> <li>f) Badanie typu WE</li> <li>4. Odniesienie do Norm harmonizowanych</li> <li>g) Zmierzony poziom mocy akustycznej</li> <li>h) Gwarantowany poziom mocy akustycznej</li> <li>k) Moc zainstalowana</li> <li>n) Osoba upoważniona do zredagowania Dokumentacji technicznej:</li> <li>o) Miejscowość i data</li> </ol>
<p><b>HU (Eredeti használati utasítás fordítása)</b></p> <p>EK-megfelelőségi nyilatkozata (2006/42/EK gépirányelv, II. melléklet "A" rész)</p> <ol style="list-style-type: none"> <li>1. Alulírott Vállalat</li> <li>2. Felelőségének teljes tudatában kijelenti, hogy az alábbi gép: Hordozható akkumulátoros láncfűrész,</li> <li>Fák kitérés/darabolása/gallyazása</li> <li>a) Típus / Alapítvány</li> <li>c) Gyártási szám</li> <li>d) Motor: akkumulátor</li> <li>3. Megfelel az alábbi irányelvek előírásainak:</li> <li>e) Tanúsító szerv</li> <li>f) CE vizsgálat típusa</li> <li>4. Hivatkozás a harmonizált szabványokra</li> <li>g) Mért zajteljesítmény szint</li> <li>h) Garantált zajteljesítmény szint</li> <li>k) Beépített teljesítmény</li> <li>n) Műszaki Dosszié szerkesztésére felhatalmazott személy:</li> <li>o) Helye és ideje</li> </ol>	<p><b>RU (Перевод оригинальных инструкций)</b></p> <p>Декларация соответствия нормам ЕС (Директива о машинном оборудовании 2006/42/ЕС, Приложение II, часть А)</p> <ol style="list-style-type: none"> <li>1. Предприятие</li> <li>2. Заявляет под собственную ответственность, что машина: Портативная цепная пила с батарейным питанием, Валка/разделка/обрезка ветвей деревьев</li> <li>a) Тип / Базовая модель</li> <li>c) Паспорт</li> <li>d) Двигатель: батарея</li> <li>3. Соответствует требованиям следующих директив:</li> <li>e) Сертифицирующий орган</li> <li>f) Испытание ЕС типового образца</li> <li>4. Ссылки на гармонизированные нормы</li> <li>g) Измеренный уровень звуковой мощности</li> <li>h) Гарантируемый уровень звуковой мощности</li> <li>k) Установленная мощность</li> <li>n) Лицо, уполномоченное на подготовку технической документации:</li> <li>o) Место и дата</li> </ol>	<p><b>HR (Prijevod originalnih uputa)</b></p> <p>EK Izjava o sukladnosti (Direktiva 2006/42/EZ o strojevima, dodatak II, dio A)</p> <ol style="list-style-type: none"> <li>1. Tvrtka</li> <li>2. pod vlastitom odgovornošću izjavljuje da je stroj: Prijenosna motorna lančana pila s baterijskim napajanjem, Obaranje/prerezivanje/obrezivanje stabala</li> <li>a) Vrsta / Osnovni model</li> <li>c) Matični broj</li> <li>d) Motor: baterija</li> <li>3. sukladna s temeljnim zahtjevima direktiva:</li> <li>e) Certifikacijsko tijelo</li> <li>f) Tipsko ispitivanje EZ</li> <li>4. Primenjene su slijedeće harmonizirane norme:</li> <li>g) Izmjerena razina zvučne snage</li> <li>h) Zajamčena razina zvučne snage</li> <li>k) Instalirana snaga</li> <li>n) Osoba ovlaštena za pravljenje Tehničke datoteke:</li> <li>o) Mjesto i datum</li> </ol>

<p><b>SL</b> (Prevod izvornih navodil)</p> <p>ES izjava o skladnosti (Direktiva 2006/42/ES), priloga II, del A)</p> <ol style="list-style-type: none"> <li>1. Družba</li> <li>2. pod lastno odgovornostjo izjavlja, da je stroj: Prenosna akumulatorska verižna žaga, podiranje/rezanje/odstranjevanje vej</li> <li>a) Tip / osnovni model</li> <li>c) Serijska številka</li> <li>d) Motor: baterija</li> <li>3. Skladen je z določili direktiv :       <ol style="list-style-type: none"> <li>e) Ustanova, ki izda potrdilo</li> <li>f) ES pregled tipa</li> <li>4. Sklicevanje na usklajene predpise</li> <li>g) Izmerjen nivo zvočne moči</li> <li>h) Zagotovljen nivo zvočne moči</li> <li>k) Instalirana moč</li> <li>n) Oseba, pooblaščenca za sestavo tehnične knjižnice:</li> <li>o) Kraj in datum</li> </ol> </li> </ol>	<p><b>BS</b> (Prijevod originalnih uputa)</p> <p>EZ izjava o skladnosti (Direktiva o mašinama 2006/42/EZ, Prilog II, deo A)</p> <ol style="list-style-type: none"> <li>1. Firma</li> <li>2. Daje izjavo pod vlastitom odgovornošću da je mašina: Ručna lančana motorna pila na bateriju, obaranje i sječa drveća/rezanje grana</li> <li>a) Tip / Osnovni model</li> <li>c) Serijski broj</li> <li>d) Motor: akumulator</li> <li>3. sukladna s osnovnim zahtjevima direktive:       <ol style="list-style-type: none"> <li>e) Certifikaciono tijelo</li> <li>f) EZ ispitivanje tipa</li> <li>4. Pozivanje na uskladene norme</li> <li>g) Izmjereni nivo zvučne snage</li> <li>h) Garantovani nivo zvučne snage</li> <li>k) Instalirana snaga</li> <li>n) Osoba ovlaštena za izradu tehničke brošure:           <ol style="list-style-type: none"> <li>o) Mjesto i datum</li> </ol> </li> </ol> </li> </ol>	<p><b>SK</b> (Preklad pôvodného návodu na použitie)</p> <p>ES vyhlásenie o zhode (Smernica o Strojnych zariadeniach 2006/42/ES, Príloha II, časť A)</p> <ol style="list-style-type: none"> <li>1. Spoločnosť</li> <li>2. Vyhlásuje na vlastnú zodpovednosť, že stroj: Prenosná akumulátorová reťazová motorová píla, stínanie/rozrezávanie/odvetvovanie stromov</li> <li>a) Typ / Základný model</li> <li>c) Výrobné číslo</li> <li>d) Motor: akumulátor</li> <li>3. Je v zhode s nariadeniami smerníc:       <ol style="list-style-type: none"> <li>e) Certifikačný orgán</li> <li>f) Skúška typu ES</li> <li>4. Odkaz na Harmonizované normy</li> <li>g) Nameraná úroveň akustického výkonu</li> <li>h) Zaručená úroveň akustického výkonu</li> <li>k) Inštalovaný výkon</li> <li>n) Osoba autorizovaná na vytvorenie Technického spisu:           <ol style="list-style-type: none"> <li>o) Miesto a Dátum</li> </ol> </li> </ol> </li> </ol>
<p><b>RO</b> (Traducerea manualului fabricantului)</p> <p>CE-Declarație de Conformitate (Directiva Mașini 2006/42/CE, Anexa II, partea A)</p> <ol style="list-style-type: none"> <li>1. Societatea</li> <li>2. Declară pe propria răspundere că mașina: Ferăstrău cu lanț alimentat cu baterie portabilă, Doborâre/secționare/tăierea ramurilor de copaci</li> <li>a) Tip / Model de bază</li> <li>c) Număr de serie</li> <li>d) Motor: baterie</li> <li>3. Este în conformitate cu specificațiile directivelor:       <ol style="list-style-type: none"> <li>e) Organism de certificare</li> <li>f) Examinare CE de Tip</li> <li>4. Referință la Standardele armonizate</li> <li>g) Nivel de putere sonoră măsurat</li> <li>h) Nivel de putere sonoră garantat</li> <li>k) Putere instalată</li> <li>n) Persoană autorizată să întocmească Dosarul Tehnic</li> <li>o) Locul și Data</li> </ol> </li> </ol>	<p><b>LT</b> (Originalių instrukcijų vertimas)</p> <p>EB atitikties deklaracija (Mašinių direktyva 2006/42/CE, Priedas II, dalis A)</p> <ol style="list-style-type: none"> <li>1. Bendrovė</li> <li>2. Prisiima atsakomybę, kad įrenginys: Nešiojamas akumulatorinis grandininis pjūklas, medžių kirtimas/pjaustymas/genėjimas</li> <li>a) Tipas / Bazinis Modelis</li> <li>c) Serijos numeris</li> <li>d) Varkiklis: baterija</li> <li>3. Atitinka direktyvose pateiktas specifikacijas:       <ol style="list-style-type: none"> <li>e) Serifikavimo įstaiga</li> <li>f) CE tipo tyrimas</li> <li>4. Nuoroda į suderintas Normas</li> <li>g) Išmatuotas garso galios lygis</li> <li>h) Užtikrinamas garso galios lygis</li> <li>k) Instaliuota galia</li> <li>n) Autorizuotas asmuo sudaryti Techninę Dokumentaciją:           <ol style="list-style-type: none"> <li>o) Vietą ir Data</li> </ol> </li> </ol> </li> </ol>	<p><b>LV</b> (Instrukciju tulkojums no oriģinālvalodas)</p> <p>EK atbilstības deklarācija (Direktīva 2006/42/EK par mašīnām, pielikums II, daļa A)</p> <ol style="list-style-type: none"> <li>1. Uzņēmums</li> <li>2. Uzņemoties par to pilnu atbildību, paziņo, ka mašīna: Ar bateriju darbināms portatīvs ķēdes zāģis, Koku gāšana/zāģēšana/atzarošana</li> <li>a) Tips / Bāzes modelis</li> <li>c) Sērijas numurs</li> <li>d) Motors: akumulators</li> <li>3. Atbilst šādu direktīvu prasībām:       <ol style="list-style-type: none"> <li>e) Serifikācijas iestāde</li> <li>f) CE tipveida pārbaude</li> <li>4. Atsauc uz harmonizētiem standartiem</li> <li>g) Izmērītais skaņas intensitātes līmenis</li> <li>h) Garantētais skaņas intensitātes līmenis</li> <li>k) Uzstādītā jauda</li> <li>n) Pilnvarotais darbinieks, kas sagatavoja tehnisko dokumentāciju:           <ol style="list-style-type: none"> <li>o) Vietu un datumus</li> </ol> </li> </ol> </li> </ol>
<p><b>SR</b> (Prevod originalnih uputstval)</p> <p>EC deklaracija o usaglašenosti (Direktiva o mašinama 2006/42/EC, Prilog II, deo A)</p> <ol style="list-style-type: none"> <li>1. Preduzeće</li> <li>2. Daje izjavu pod vlastitom odgovornošću da je mašina: Ručna lančana motorna testera na bateriju, obaranje i seča drveća/rezanje grana</li> <li>a) Tip / Osnovni model</li> <li>c) Serijski broj</li> <li>d) Motor: akumulator</li> <li>3. u skladu s osnovnim zahtevima direktiva:       <ol style="list-style-type: none"> <li>e) Certifikaciono telo</li> <li>f) EC ispitivanje tipa:           <ol style="list-style-type: none"> <li>4. Pozivanje na uskladene norme</li> <li>g) Izmereni nivo zvučne snage</li> <li>h) Garantovani nivo zvučne snage</li> <li>k) Instalirana snaga</li> <li>n) Osoba ovlašćena za sastavljanje tehničke brošure</li> <li>o) Mesto i datum</li> </ol> </li> </ol> </li> </ol>	<p><b>BG</b> (Превод на оригиналните инструкции)</p> <p>EO декларация за съответствие (Директива Машини 2006/42/EO, Приложение II, част А)</p> <ol style="list-style-type: none"> <li>1. Дружеството</li> <li>2. На собствена отговорност декларира, че машината: Моторен верижен трион захранван с преносима акумулаторна батерия, Сеч/нарязване на трупи/коакстрияне клоните на дървета</li> <li>a) Вид / Базисен модел</li> <li>в) Сериен номер</li> <li>г) Мотор: акумулатор</li> <li>3. Е в съответствие със спецификациите на директивите:       <ol style="list-style-type: none"> <li>д) Сертифициращ орган</li> <li>е) EO изследване на вида</li> <li>4. Базирано на хармонизираните норми</li> <li>ж) Ниво на измерена акустична мощност</li> <li>и) Гарантирано ниво на акустична мощност</li> <li>к) Инсталирана мощност</li> <li>р) Лице, упълномощено да състави Техническата Документация:           <ol style="list-style-type: none"> <li>o) Място и дата</li> </ol> </li> </ol> </li> </ol>	<p><b>ET</b> (Algupärase kasutusjuhendi tõlge)</p> <p>EÜ vastavusdeklaratsioon (Masinadirektiiv 2006/42/EÜ, Lisa II, osa A)</p> <ol style="list-style-type: none"> <li>1. Firma</li> <li>2. Kinnitab omal vastutusel, et masin: Kaasaskantav akutoitega kettsaag, Puude langetamine/järkamine/laasimine</li> <li>a) Tüüp / Põhimudel</li> <li>c) Matriikkel</li> <li>d) Mootor: aku</li> <li>3. Vastab direktiivide nõuetele:       <ol style="list-style-type: none"> <li>e) Kinnitav asutus</li> <li>f) EÜ tüübihindamine</li> <li>4. Viide ühtlustatud standarditele</li> <li>g) Mõõdetud helivõimsuse tase</li> <li>h) Garanteeritud helivõimsuse tase</li> <li>k) Installeeritud võimsus</li> <li>n) Tehnilise Lehe autoriseeritud koostaja:           <ol style="list-style-type: none"> <li>o) Koht ja Kuupäev</li> </ol> </li> </ol> </li> </ol>

**IT** • Il contenuto e le immagini del presente manuale d'uso sono stati realizzati per conto di ST. S.p.A. e sono tutelati da diritto d'autore – È vietata ogni riproduzione o alterazione anche parziale non autorizzata del documento.

**BG** • Съдържанието и изображенията в настоящото ръководство са извършени за ST. S.p.A. и са защитени с авторски права – Забранява се всяко неотторизирано възпроизвеждане или промяна, дори и отчасти на документа.

**BS** • Sadržaj i slike iz ovog korisničkog priručnika napravljeni su isključivo za ST. S.p.A. i zaštićeni su autorskim pravima – zabranjena je svaka neovlaštena reprodukcija ili izmjena dokumenta, djelomično ili u potpunosti.

**CS** • Obsah a obrázky v tomto návodu k použití byly zpracovány jménem společnosti ST. S.p.A. a jsou chráněny autorským právem – Reprodukce či nepovolené pozměňování tohoto dokumentu, a to i částečné, je zakázáno.

**DA** • Indhold og illustrationer i denne vejledning er blevet skabt på vegne af ST. S.p.A. og er beskyttet af ophavsret – Enhver gengivelse eller ændring, også delvis, af dokumentet uden autorisation hertil er forbudt.

**DE** • Inhalt und Bilder dieser Bedienungsanleitung wurden im Namen von ST. S.p.A. erstellt und sind urheberrechtlich geschützt – Jede nicht genehmigte Vervielfältigung oder Veränderung, auch auszugsweise, dieses Dokuments ist verboten.

**EL** • Το περιεχόμενο και οι εικόνες στο παρόν εγχειρίδιο χρήσης δημιουργήθηκαν για λογαριασμό της εταιρείας ST. S.p.A. και προστατεύονται από πνευματικά δικαιώματα – Απαγορεύεται οποιαδήποτε αναπαραγωγή ή τροποποίηση, έστω και μερική, του εγχειρίδιου χωρίς έγκριση.

**EN** • The content and images in this User Manual were produced expressly for ST. S.p.A. and are protected by copyright – any unauthorised reproduction or modification to the document, either partially or in full, is prohibited.

**ES** • El contenido y las imágenes del presente manual de uso han sido creados por ST. S.p.A. y están protegidos por los derechos de autor – Se prohíbe toda reproducción o modificación, incluso parcial, no autorizada del documento.

**ET** • Käesoleva kasutusjuhendi sisu ja kujutised on toodetud konkreetselt ettevõttele ST. S.p.A. ja neile rakendub autoriõigusseseadus – dokumendi igasugune osaline või täielik ilma loata reprodutseerimine või muutmine on keelatud.

**FI** • Tämän käyttöoppaan sisältö ja kuvat on valmistettu ST. S.p.A. -yhtiön toimesta ja niitä suojava tekijänoikeuslaki. – Asiakirjan kaikenlainen kopioiminen tai muuttaminen, osittainkin, on kielletty ilman erityistä lupaa.

**FR** • Le contenu et les images du présent manuel d'utilisation ont été réalisés pour le compte de ST. S.p.A. et sont protégés par un droit d'auteur – Toute reproduction ou modification non autorisée, même partielle, du document, est interdite.

**HR** • Sadržaj i slike u ovom priručniku za uporabu izrađeni su za tvrtku ST. S.p.A. te su obuhvaćeni autorskim pravima – Zabranjuje se neovlašteno umnožavanje ili prilagodba, djelomična ili u cijelosti, ovog dokumenta.

**HU** • Ennek a használati útmutatónak a tartalma és a benne szereplő képek kizárólag a ST. S.p.A. számára készültek és szerzői joggal védettek – tilos a dokumentum bármely részének vagy egészének engedély nélküli sokszorosítása és módosítása.

**LT** • Šio naudotojų vadovo turinys ir paveikslėliai skirti tik „ST. S.p.A.“ ir yra saugomi autorių teisėmis – dokumentą atgaminti ar modifikuoti, visiškai arba iš dalies, yra draudžiami.

**LV** • Šis lietotāja rokasgrāmatas saturs un attēli ir veidoti tikai ST. S.p.A. un ir aizsargāti ar autortiesībām. Jebkāda dokumenta vai tā daļas prettiesiska kopēšana vai pārveide ir stingri aizliegta.

**MK** • Содржината и сликите во Упатството за корисникот се подготвени исклучиво за ST. S.p.A. и се заштитени со авторски права – забрането е секое делумно или целосно неовластено репродуцирање или измена на документот.

**NL** • De inhoud en de afbeeldingen van deze gebruikshandleiding werden gerealiseerd voor rekening van ST. S.p.A. en zijn beschermd door het auteursrecht – Elke niet-geautoriseerde reproductie of wijziging, ook gedeeltelijke, van het document is verboden.

**NO** • Innholdet og bildene i denne brukerveiledningen er utført på oppdrag fra ST. S.p.A. og er beskyttet ved opphavsrett – Enhver gjengivelse eller endring, selv kun delvis, er forbudt.

**PL** • Treść oraz ilustracje zawarte w niniejszej instrukcji obsługi powstały na zlecenie spółki ST. S.p.A. i są chronione prawami autorskimi – Zabrania się wszelkiego kopiowania bądź modyfikowania, także częściowego, niniejszego dokumentu bez uzyskania stosownej zgody.

**PT** • As imagens e os conteúdos contidos no presente Manual do Utilizador foram expressamente criados para uso exclusivo da ST. S.p.A., encontrando-se protegidos por direitos de autor. Qualquer tipo de reprodução ou alteração, parcial ou integral, não autorizadas deste Manual estão expressamente proibidas.

**RO** • Conținutul și imaginile din manualul de utilizare de față au fost realizate în numele ST. S.p.A. și sunt protejate de drepturi de autor – Este interzisă orice reproducere sau modificare chiar și parțială neautorizată a documentului.

**RU** • Тесты и изображения, содержащиеся в настоящем руководстве, были созданы в интересах ST. S.p.A. и защищены авторскими правами – Любое несанкционированное воспроизведение или изменение документа запрещено.

**SK** • Obsah a obrázky v tomto návode na používanie boli spracované menom spoločnosti ST. S.p.A. a sú chránené autorským právom – Reprodukcie či nepovolené pozměňovanie tohto dokumentu, a to aj čiastočné, je zakázané.

**SL** • Vsebine in slike v tem uporabniškem priručniku so izdelane za podjetje ST. S.p.A. in so zaščitene z avtorskimi pravicami – vsakršno nepooblaščenno razmnoževanje ali spreminjanje dokumenta, v celoti ali delno, je prepovedano.

**SR** • Sadržaj i slike ovog priručnika za upotrebu su napravljeni u ime ST. S.p.A. i zaštićeni su autorskim pravima – Zabranjena je svaka potpuna ili delimična reprodukcija ili izmena dokumenta bez odobrenja.

**SV** • Innehållet och bilderna i denna användarhandbok har framställts för ST. S.p.A. och skyddas av upphovsrätt – all form av reproduktion eller ändring, även partiell, som inte auktoriserats är förbjuden.

**TR** • Bu Kullanıcı Kilavuzundaki içerik ve resimler açığıca ST. S.p.A. için üretilmiştir ve telif hakkı ile korunmaktadır – dokümanın izinsiz olarak tamamen ya da kısmen herhangi bir şekilde çoğaltılması ya da dağıtılması yasaktır.



	 <b>LWA</b>  <b>dB</b>
Type: .....	
Art.N ..... ..... -s/n .....	



**FR**

Cet appareil,  
ses accessoires,  
piles et cordons  
se recyclent

À DÉPOSER  
EN MAGASIN  
OU  
À DÉPOSER  
EN DÉCHÈTERIE

Points de collecte sur [www.quefairedemesdechets.fr](http://www.quefairedemesdechets.fr)  
Privilégiez la réparation ou le don de votre appareil !



**FR**

**ST. S.p.A.**  
Via del Lavoro, 6  
31033 Castelfranco Veneto (TV) ITALY

**STIGA LTD (UK Importer)**  
Unit 8, Bluewater Estate Plympton,  
Devon, PL7 4JH, England